

保定钧运

专业品质 · 引领未来

PROFESSIONAL QUALITY · LEADS THE FUTURE



保定钧运起重机械有限公司



您身边的起重和搬运设备专家 EXPERT IN HANDLING AND LIFTING EQUIPMENT AROUND YOU

电话:13483452631/19868822138

邮箱:junyunsteven@163.com

保定钧运起重机械有限公司
Baoding Junyun Hoisting Machinery Co., Ltd

公司简介

Company Profile

保定钧运起重机械有限公司有限公司成立2001年，是专业生搬运车、堆高车、小吊机、微电提升机、手拉葫芦、电动葫芦等产品的民营企业，公司自成立以来，不断引进先进的设备和技术，已开发研制生产出数十种起重搬运设备，以服务大众为主，主要特性操作简单，性能稳定，稍有机械常识都能操作。

本公司在产品开发的过程中致力于追求质量和款式的领先，凭借多年的设计与制造经验，以优良的品质和信誉获得广大客商的青睐，生产的产品均达到国家行业标准。还可根据客户要求设计定做各种规格产品，或来料来样加工定做。本公司管理体系严格规范，工作程序严谨完善，规章制度成熟健全。严格企业的发展设计、开发、生产、管理等流程。为了招贤纳士、储备人才，公司制定了多福利待遇，为广大员工提供广阔的发展空间。在一定程度上缓解了企业周边环境的就业、再就业的压力。随着改革开放的深入及市场经济的进步发展，我公司为了进一步拓宽市场，本着互惠互利的原则，在提高产品质量的同时，让利与企业代理商，欢迎广大用户来函来电联系订货或派员来参观指导。

Baoding Junyun Crane Machinery Co., Ltd., established in 2001, is a private enterprise specializing in the production of forklifts, stackers, small cranes, electric hoists, manual chain blocks, electric chain blocks, and other lifting equipment. Since its inception, the company has continuously introduced advanced equipment and technology, developing and manufacturing dozens of types of lifting and handling devices. With a focus on serving the public, its products are characterized by simple operation, stable performance, and ease of use for individuals with basic mechanical knowledge.

During the product development process, our company is committed to pursuing excellence in quality and design. Leveraging years of design and manufacturing experience, we have earned the trust of numerous clients with superior quality and reputation. All products produced meet national industry standards. Additionally, we offer customized solutions for various specifications based on client requirements or OEM/ODM services. Our management system is strictly standardized, with rigorous and well-established procedures, mature and comprehensive regulations, and a stringent process for enterprise development—covering design, development, production, and management. To attract talent and cultivate reserves, the company has implemented a range of welfare benefits, providing employees with extensive development opportunities. This helps alleviate employment and reemployment pressures in the surrounding area to a certain extent. With the deepening of reform and opening-up and the advancement of the market economy, our company aims to further expand its market. Adhering to the principle of mutual benefit, we improve product quality while offering favorable terms to enterprises and agents. We welcome customers to contact us via letter or phone for orders or to arrange visits for guidance.

PRODUCTCATALOG

HAND PALLET TRUCK 手动液压搬运车	01-02
SSPALLET TRUCK 手动液压搬运车	03
HAND PALLET TRUCK WITH SCALE 手动带称液压搬运车	04
HEAVY-DUTY OFF-ROAD SIMI-ELECTRIC PALLET TRUCK 重型越野半电动/电动搬运车	05
SEMI-ELECTRIC/ELECTRICPALLETTRUCK 半电动/电动搬运车	06
OFF-ROAD SEMI-ELECTRIC/ELECTRIC CARRIER 越野半电动/电动搬运车	07
NORMALSELF-LOAD STACKER 简易款随车叉车	08
MANUAL STACKERC-TYPE DOUBLE FRAME C型钢双龙门堆高车	09
MANUAL STACKER SINGLETYPE FRAME 手动堆高车C型钢单门架	10
I TYPE MANUAL STACKER 手动堆高车槽钢	11
H TYPE STACKER 手动堆高车工字钢	12
SEMI ELECTRIC STACKER 半电动堆高车	13
FULL ELECTRIC STAND-ONTYPESTACKER 全电动站立式堆高车	14
FULL ELECTRIC WALKIE TYPE STACKER 全电动步行式堆高车	15
HYDRAULIC OIL DRUM STACKER 液压油桶倒料车	16
OIL DRUM 油桶搬运车	17
HYDRAULIC LIFT TABLE 液压平台车	18-19
CAR ENGINES CRANES 汽车发动机起重机	20
MANUAL HIGHLIFT SCISSOR TRUCK 手动高起升搬运车	21
500KG OUTDOOR CRANE/MONKEY CRANE 500KG室外吊机	22
800KG OUTDOOR CRANE/MONKEY CRANE 800KG室外吊机	23
1000KG OUTDOOR CRANE/MONKEY CRANE 1000KG室外吊机	24
OUTDOOR CRANE/MONKEY CRANE 室外吊机	25
HSZ CHAIN BIOCK HSZ手拉葫芦	26
VT CHAIN BIOCK VT手拉葫芦	27
VC CHAIN BIOCK VC手拉葫芦	28
VD CHAIN BIOCK VD手拉葫芦	29
VD-II CHAIN BIOCK VD-II手拉葫芦	30

PRODUCTCATALOG

HS-T CHAIN BIOCK HS-T手拉葫芦	31
HS-V CHAIN BIOCK HS-V手拉葫芦	32
HSS CHAIN BIOCK HSS手拉葫芦	33
VL LEVER HOIST VL手扳葫芦	34
VA LEVER HOIST VA手扳葫芦	35
220V/380V ELECTRIC HOIST 220V/380V电动葫芦	36
CD1WIRE ROPE ELECTRIC HOISTS CD1钢丝绳电动葫芦	37
HEIGH SPEED HOIST 小金钢电动葫芦	38
DHS ELECTRIC HOIST DHS电动葫芦	39
MINL ELECTRIC HOISY 微型电动葫芦	40
HHBB ELECTRIC CHAIN HOISY 环链电动葫芦	41
HHBB ELECTRIC CHAIN HOISY WITH TROLLEY 运行式环链电动葫芦	42
KCD ELECTRIC WINCH 铝壳提升机	43
ELECTRIC CLUBTH WINCH 压盘提升机	44
JEEP WINCH JEEP钢盘	45
3P WINCH 3项电提升机	46
3P ELECTRIC WINCH 卷扬机	47
CD-K1 ELECTRIC WINCH 二代提升机	48
PULL THE CART 手拉跑车	49
TANK TRANSPORTER 坦克搬运车	50
WO SHI JACKING SCISSOR JACKS 剪式千斤顶	51
PNEUMATIC JACKS 气动千斤顶	52
SCREW JACKS 螺旋千斤顶	53
HAND WINCH 手摇绞车	54
G80 CHAIN PARAMETERS G80链条	55
PERMANENT MAGNET CHUCK 永磁吸盘	56
STEEL PLATE LIFTING PLIERS 钢板起重钳子	57
HOOK SERIES 钩子系列	58

手动液压 搬运车

HAND PALLET TRUCK

技术参数 Technical Parameters

Model/型号	BF2000 NY	BF2000 NY-2	BF2000 PU	BF2000 PU-2	BF2500 NY	BF2500 NY-2	BF2500 NY-2
Fork length/货叉长	1150	1220	1150	1220	1150	1220	1220
Fork length/货叉宽	550	685	550	685	550	685	685
Maximum lifting height of fork/最高提升高度	200	200	200	200	200	200	200
Wheel material/轮子材质	Nylon/尼龙	Nylon/尼龙	PU	PU	Nylon/尼龙	Nylon/尼龙	Nylon/尼龙
Wheel size/轮子尺寸	"180*50/ 80*70"	"180*50/ 80*70"	"180*50/ 80*70"	"180*50/ 80*70"	"180*50/ 80*70"	"180*50/ 80*70"	"180*50/ 80*70"
Th of steel plate before painting/喷漆前钢板厚度	2.75	2.75	2.75	2.75	2.75	2.75	2.75
Thickness of steel plate after spraying/喷漆后钢板厚度	3	3	3	3	3	3	3
Reinforcement length/加筋长度	30MM	30MM	30MM	30MM	30MM	30MM	30MM
Whether the handle is wrapped with rubber/是否包胶	Yes/是	Yes/是	Yes/是	Yes/是	Yes/是	Yes/是	Yes/是
Lever/拉杆	+	+	+	+	+	+	+
Aux wheel/辅助轮	+	+	+	+	+	+	+
Quantity/数量							

技术参数 Technical Parameters

Model/型号	BF2500 PU	BF2500 PU-2	BF3000 NY	BF3000 NY-2	BF3000 PU	BF3000 PU-2
Fork length/货叉长	1150	1220	1150	1220	1150	1220
Fork length/货叉宽	550	685	550	685	550	685
Maximum lifting height of fork/最高提升高度	200	200	200	200	200	200
Wheel material/轮子材质	PU	PU	Nylon/尼龙	Nylon/尼龙	PU	Nylon/尼龙
Wheel size/轮子尺寸	"180*50/ 80*70"	"180*50/ 80*70"	"180*50/ 80*70"	"180*50/ 80*70"	"180*50/ 80*70"	"180*50/ 80*70"
Th of steel plate before painting/喷漆前钢板厚度	2.75	2.75	3.5	3.5	3.5	2.75
Thickness of steel plate after spraying/喷漆后钢板厚度	3	3	3.75	3.75	3.75	3
Reinforcement length/加筋长度	30MM	30MM	750MM	750MM	750MM	30MM
Whether the handle is wrapped with rubber/是否包胶	Yes/是	Yes/是	Yes/是	Yes/是	Yes/是	Yes/是
Lever/拉杆	+	+	+	+	+	+
Aux wheel/辅助轮	+	+	+	+	+	+
Quantity/数量						

HAND PALLET TRUCK

手动液压 搬运车



不锈钢 手动液压 搬运车

SS PALLETTRUCK

技术参数 Technical Parameters

Model/型号	550*1150	550*1150
Maximum load(kg)/最大负载(千克)	2000	3000
Large wheel size(mm)/大车轮尺寸(毫米)	180*50	180*50
Small wheel size(mm)/小车轮尺寸(毫米)	74*70	74*70
Outside fork width(mm)/货叉外部宽度(毫米)	540	540
Inside fork width(mm)/货叉内部宽度(毫米)	220	220
Fork length(mm)/货叉长度(毫米)	1150	1150
Minimum fork placement(mm)/最小货叉放置距离(毫米)	85	85
Maximum fork placement(mm)/最大货叉放置距离(毫米)	205	205



HAND PALLET TRUCK WITH SCALE

手动 带称液压 搬运车

技术参数 Technical Parameters

Fork length/货叉长度	1200mm
Fork width exterior/货叉外宽	550/685mm
Fork width interior/货叉内宽	230/365mm
Lifting method/升降方式	Manual lifting/手动升降
wheel/轮子	Nylon wheel/polyurethane wheel 尼龙轮/聚氨酯轮
Front wheel/前轮	Diameter 80mm/width 70mm 直径80mm/宽70mm
Fork length/货叉长度	1150
Fork outerwidth/货叉外宽	550/685
Turning radius/转弯半径	1265
DCpower suply/直流电源	6V/4AH
Net weight/净重	92/95



重型越野 半电动/电动 搬运车

HEAVY-DUTY OFF-ROAD SEMI-ELECTRIC PALLET TRUCK

技术参数 Technical Parameters

Fork length/货叉长度	1200mm
Fork width exterior/货叉外宽	550/685mm
Fork width interior/货叉内宽	230/365mm
Battery type/电瓶类型	Lead-acid battery
Battery capacity/电瓶容量	48V-20Ah/48V-32Ah
Speed of travel/行驶速度	5km/h
Lifting method/升降方式	Manual lifting/electric lifting 手动升降/电动升降
Driving wheel/驱动轮子	Diameter 300mm/width 100mm 直径300mm/宽100mm
Front wheel/前轮	Diameter 80mm/width 70mm 直径80mm/宽70mm

SEMI-ELECTRIC/ELECTRIC PALLETTRUCK

半电动/电动 搬运车

技术参数 Technical Parameters

Fork length/货叉长度	1160mm
Fork width exterior/货叉外宽	550/685mm
Fork width interior/货叉内宽	230/365mm
Battery type/电瓶类型	Lead-acid battery
Battery capacity/电瓶容量	48V-20Ah/48V-32Ah
Speed of travel/行驶速度	5km/h
Lifting method/升降方式	Manual lifting/electric lifting 手动升降/电动升降
Driving wheel/驱动轮子	Diameter 160mm/width 55mm 直径160mm/宽55mm
Front wheel/前轮	Diameter 80mm/width 70mm 直径80mm/宽70mm



越野 半电动/电动 搬运车

OFF-ROAD SEMI-ELECTRIC/ELECTRIC CARRIER

技术参数 Technical Parameters

Fork length/货叉长度	1200mm
Fork width exterior/货叉外宽	550/685mm
Fork width interior/货叉内宽	230/365mm
Battery type/电瓶类型	Lead-acid battery
Battery capacity/电瓶容量	48V-20Ah/48V-32Ah
Speed of travel/行驶速度	5km/h
Lifting method/升降方式	Manual lifting/electric lifting 手动升降/电动升降
Driving wheel/驱动轮子	Diameter 300mm/width 100mm 直径300mm/宽100mm
Front wheel/前轮	Diameter 80mm/width 70mm 直径80mm/宽70mm



NORMAL SELF-LOAD STACKER

简易款 随车叉车

技术参数 Technical Parameters

badlg)	9001000
Lftrghegt(mm)/前轮距(mm)	13001600
Totalbodywidtnyom/车身总宽(毫米)	850
Overallenghtimml/全长(毫米)	1400
Forkwktiimmy/叉距(毫米)	550
orksizefimml/工作尺寸(毫米)	100550
Battery V4/电池	48V/154H
Totalweigtnng/总重量	185



C型钢 双龙门 堆高车

MANUAL STACKERC-TYPE DOUBLE FRAME

技术参数 Technical Parameters

Stock Number/物料编码	单位/Unit	规格specifications	
Fated Load/额定载重	kg	2000	2000
Lad Center/负载中心	mm	550	550
Fork Height/提升高度	mm	2000	3000
Minimum Fork Height/最低货叉高度	mm□	75□	75□
Fork Length/货叉长度	mm	1090	1090
Single Fork Wdth/单个货叉宽度	mm	140	140□
Adjustable Fork Wdth/可调货叉宽度范围	mm	300-820	300-820
CPUMearing/鼓垂轮	mm	中70MBD	中70wB0
PUVRear/后轮	mm	中50×180	中50×180
Overall Size/整机尺寸	mm	1670x830x1600	1670x830x2000
Net weight/净重	Kg	250	260



手动 堆高车 C型钢 单门架

MANUAL STACKER SINGLETYPE FRAME

技术参数 Technical Parameters

stockNumber/物料接码	单位/Uunit	规格specifications	
Rated Load/额定载重	kg	1000	2000
Lad center/负载中心	mm	550	550
Fork Height/提升高度	mm	1600	1600
Minimum Fork Height/最低货叉高度	mm	70	90
FokLength/货叉长腹	mm	930	1080
Sigle Fork wicth/单个货叉宽度	mm	120	140
Adjustable Fark width/可调货叉宽度范围	mm	520-800	520-800
Bearing/驻重轮(PU)	mm	中70×80	φ70×80
Reer/后轮(PU)	mm	450×180	450×180
Oerll ize/整机尺寸	mm	1530×835×2040	1670×835×2040
Net wight/净重	kg	150	180



手动 堆高车 槽钢

I TYPE MANUAL STACKER

技术参数 Technical Parameters

Stock Number/物料编码	单位/Unit	规格Specifications	
Rated Load/额定载重	kg	500	1000
Load Center/载荷中心	mm□	550	550
Max.Fork Height/货叉最高高度	(H)mm	1100	1600
Min.Fork Height/货叉最低高度	(h)mm	80	70
Fork Length/货叉长度	(L)mm	800	830
Minimum Fork Height/单个货叉宽度	[D]mm	80	100
Fork Overall Width/货叉整体宽度	(M)mm	460	600
Ground Clearance/离地间距	(X)mm	30	27□
Min.Turning Radius/最小转弯半径	mm□	1375□	1375
Front wheel size/前轮尺寸	mm□	450×90	◆70×80
Rear/后轮(PU)	mm	中50×180	450×180
Overall Length/整车长度	(A)mm□	1300	1380
Overall Width/整车宽度	(B)mm	610□	750
Overall Height/整车高度	(F)mm	1595	2040
Net weight/净重	g	100	130



手动 堆高车 工字钢

H TYPE STACKER

技术参数 Technical Parameters

Stock Number/物料编码	单位/Unit	规格Specifications	
Lifting weight/起重量	kg	2000	3000
Lifting height/起升高度	mm	1600	1600
Load center distance/载荷中心距	mm	550	600
The mast length/货叉长度	mm□	830	900
Mast fork width adjustment/货叉调节宽度	mm□	240-810	320-800
Pallet fork minimum height/指叉最低高度	mm	70□	90
The minimum bending radius/最小转弯半径	mm	1415	1450
The vehicle length/整车长度	mm□	1280	1580□
Vehicle width/整车宽度	mm□	850	800
The vehicle height/整车高度	mm	2040	2040
The wheels (nylon)/车轮/尼龙	mm	70×80/50×180	70×80/50×175
Dead weight/自重	kg	160□	280□



半电动 堆高车

SEMI ELECTRIC STACKER

技术参数 Technical Parameters

Model/规格型号	单位/Unit	1T1.6M	2T1.6M	2T2M	2T2.5M	2T3M□	2T35M□
overallHeight/整车高度	mm	2050	2000	600	1680	2000	2250
Net weight/净重	kg□	260	280□	330□	340	370	350
ForkLength/货叉长度	mm	940	1080	1080	1080	1080	1080
Minimum Fork Height/单个货叉宽度	mm□	120	140□	140	140	140	140
Overall Length/整车长	mm	1570	1730	1730	730	1730	1730
Overall width/整车宽	mm	860	860□	860	860	860	860
Forkoveral Width/货叉整体宽度	mm	815	815	815	815	815	815□
Forkspecifications/叉固规格	mm	80×50□	80×50	80×50	80×50	80×50	80×50
Wide outside forkleg/叉腿外宽	mm	615	615	615	615	615	615
Turningradius/转弯半径	mm□	1500	1500	1500	1500	1500	1500
The wheelbase/轴距	mm	1133	1133	1133	1133	1133	1133
Speed/提升速度	mms	装整每影30mm,空最每秒133mm					
Drop speed/下降速度	mms	满鼓每秒10mm,空鼓每秒113mm					
Lifting motor power/提升电机功率	kw□	15	15	15	15	15	15
Battery capacity and voltage/电池容量及电压	AN	120A12V	120A12V	120A12V	120A 12V	120A12V	120A12V
Drive form□/驱动形式		半电动/Semi-electric					
Drivingway/驾辣方式		步行式Pedestrian					



FULL ELECTRIC STAND-ON TYPE STACKER

全电动 站驾式 堆高车

技术参数 Technical Parameters

Load weight T	1						15						2	
Lifting height MM	16	2	2.5	3	3.5	6	2	2.5	3	3.5	1.6	2.5		
Maximum mast height MM	2015	55	805	2055	2305	2015	155	1805	2055	2305	2015	55	805	
Overall width MM	800													
Fork size MM	1150*150*60													
Maximum fork height MM	90□													
Load-bearing wheel MM	7470													
Steering wheel MM	150*50													
Ground clearance MM	25													
Battery	DC24V140AH(可加装到270AH)													
Estimated total weight / NG	550	630	660	680	720	570	650	680	700	740	605	685	715	



全电动 步行式 堆高车

FULL ELECTRIC WALKIE TYPE STACKER

技术参数 Technical Parameters

Load weight/T	1				1.5				2					
Lifting height M	16	2	2.5	3.5	6	2	2.5	3	3.5	6	2	2.5	3	
Maximum door height/MM 2	0151	5551	80520	5523	052	01515	5518	052	0552	3052	015	555	8052055	
Overall vehicle length M	800													
Fork size MM	1150*150*60													
Minimum fork height M	90													
Load-bearing wheel MM	74*70													
Steering wheel MM	150*50													
Ground clearance MM	25													
Battery	DC24V/140AH阿加该到160AH0													
Estimated total weight/KG	380	480	510	550	590	400	500	530	570	610	435	535	565	605



HYDRAULIC OIL DRUM STACKER

液压油桶 倒料车

技术参数 Technical Parameters

Stock Number/物料编码	单位/Unit	
type/类型	鹰端式/Olecranon type3	
Ratedload/额定鼓重	kg	450KG 2055
Drum size/油桶尺寸规格	mm	55加仑/Gallon、钢制/Stel1572
Lit height/举升高度	mm	1350
Net Weight/净重	kg	190



油桶 搬运车

OIL DRUM

技术参数 Technical Parameters

Masimum lbad/最大鼓荷	450g
Mairumfigheijit/最大起升高度	250mm
Mairumdameterofoldrum/油物品大直扬	600mm
Masimum heghtofoildnum/油桶最大高度	915mm
Frontyre/前轮尺寸	50*40mm
steingwel sze/转向轮尺寸	125*38mm
OwealLeregh/壁车高度	1250mm
OuealVvich/整车宽鹰	760mm
Net Weigt/净面	42kg



HYDRAULIC LIFT TABLE

液压 平台车



液压 平台车

HYDRAULIC LIFT TABLE

技术参数 Technical Parameters

Model/型号	Rated load 额定载重(kg)	Worktop size 台面尺寸(mm)	Minimum-Maximum 最低-最高(mm)	Reference weight 参考重量(kg)	
	150KG*0.72m	700*450*35	230-720	44	
	150KG*0.72m	700*450*35	230-720	45	Foldable/折叠款
	150KG*1.26m	700*450*35	295-1260	55	
Integral cylinder 一体油缸	150KG*1.26m	700*450*35	295-1260	58	Foldable/折叠款
	200KG*2m	905*500*50	440-2000	126	
	500KG*0.9m	815*500*50	290-900	74	Foldable/折叠款
	500KG*0.9m	815*500*50	290-900	75	
	350KG*1.5m	905*500*50	390-1500	104	
	500KG*1.5m	905*500*50	390-1500	104	
	1000KG*1m	1000*500*60	420-1000	110	
	500KG*1.5m	905*500*50	390-1500	108.85	
Split hydraulic cylinder 分体油缸	500KG*2m	905*500*50	440-2000	143	
	800kg*1.5m	1200*600*50	480-1700	165	
	1000KG*1.7m	1200*600*80	530-1700	212	
	1000KG*1.7m	1300*800*80	530-1700	274	
					Customized model with support legs/定制款带支腿
Fixed platform 固定平台	1000KG*1m	1300*820*80	200-1000	190	With rack 6kg/带架子+6kg
	1000KG*0.8m	1300*1000*80	200-800	266	
	1000KG*1.78m	1300*820*80	305-1780	244	With fence 266kg/带护栏266kg
Split double cylinder 分体双油缸	1000KG*1m	1200*600*80		169	
	1000KG*1.7m	1200*600*80	500-1700	258	
Semi-electric 半电动	500KG*1.5m	905*500*50	360-1500	142	
	500KG*2m	905*500*50	450-2000	175	
	500KG*3m	1300*800*80	550-3000	340	

CAR ENGINES CRANES

汽车 发动机 起重机

技术参数 Technical Parameters

2T Folding model	
Rated load/额定载荷	2T
Lifting weight/起吊重量	500kg
Lifting height/起吊高度	1800m
Minimum height/最低高度	300mm
Net weight/净重	63kg
Wheels/轮子	Six universalwheels

技术参数 Technical Parameters

3T fixed crane	
Rated load/额定载荷	3T
Lifting weight/起吊重量	800kg
Lifting height/起吊高度	2200mm
Minimum height/最低高度	300mm
Net weight/净重	83-110kg
Wheels/轮子	2 universal wheels 2 fixed iron wheels



手动 高起升 搬运车

MANUAL HIGHLIFT SCISSOR TRUCK

技术参数 Technical Parameters

MODEL/型号	HL5510
ARcgT/载重	1500
cDoSePiG/最低高度	85
MAXHEIGHT (MM)/最高高度	800
oih/货叉长鹰	1150
am iecs/大轮直径	φ160*50
RouEBSizE/小轮尺寸	φ80*70
PCYsizE/包装尺寸	φ80*70
ET GH/净重	110



500KG OUTDOOR CRANE/ MONKEY CRANE

500KG 室外 吊机

技术参数 Technical Parameters

底座尺寸:长*宽: Base dimensions: Length * Width:	吊臂长度: Boom length:	高度: high:	净重: net weight:
0.73*0.73m	2.3m	2.2m	45KG/55KG/65KG



保定钧运起重机械有限公司

800KG 室外 吊机

800KG OUTDOOR CRANE/ MONKEY CRANE

技术参数 Technical Parameters

底座尺寸:长*宽: Base dimensions: Length * Width:	吊臂长度: Boom length:	高度: high:	净重: net weight:
0.85*0.85m	2.95m	2.8m	75KG



1000KG 室外 吊机

1000KG OUTDOOR CRANE/ MONKEY CRANE

技术参数 Technical Parameters

底座尺寸:长*宽: Base dimensions: Length * Width:	吊臂长度: Boom length:	高度: high:	净重: net weight:
0.9*0.9m	2.95m	2.6m	95KG



保定钧运起重机械有限公司

室外吊机

OUTDOOR CRANE/ MONKEY CRANE



HSZ 手拉葫芦

HSZ CHAIN BLOCK

技术参数 Technical Parameters

Model		HSZ-1	HSZ-2	HSZ-3
Capacity	tons	1	2	3
Standard Lih	m	2.5	2.5	3
Ramning Test [.osd	KN	15	30	45
Effert Required to lift Rated Lond	N	309	314	343
Strmus of ooxl Cloin		1	2	2
Diuneter of t ond Clean	mm	6	6	8
Dinensions(ann)	A	142	142	178
	B	122	122	139
	C	335	470	555
	D	40	50	55
	K	26	34	37
Ner Weiglut	kg	10	14	24
Packlng easurenieut	cm	30*24*18	38*30*20	45*35*24
Extra Weight per Meter of Extra lift	kg	1.7	2.5	3.7

技术参数 Technical Parameters

Model		HSZ-5	HSZ-5	HSZ-10	HSZ-15	HSZ-20
Capacity	tons	5	5	10	15	20
Standard Lih	m	3	3	3	3	3
Ramning Test [.osd	KN	75	75	125	200	250
Effert Required to lift Rated Lond	N	383	383	392	392	392
Strmus of ooxl Cloin		2	2	4	6	8
Diuneter of t ond Clean	mm	10	10	10	10	10
Dinensions(ann)	A	210	210	358	400	580
	B	162	162	162	196	189
	C	720	720	820	923	1040
	D	65	65	85	110	110
	K	41	41	50	80	80
Ner Weiglut	kg	36	36	68	117	155
Packlng easurenieut	cm	33*27*16	33*27*16	62*50*28	70*46*75	70*46*75
Extra Weight per Meter of Extra lift	kg	5.3	5.3	9.7	14.1	19.4



VT 手拉葫芦

VT CHAIN BLOCK

技术参数 Technical Parameters

Model (kg)	Lifting weight	Standard lifting height(m)	Experimental load(ton)	Lifting chain (Number of rows)	Number of rows (millimeter)	Dimensions(M)			Net weight (kg)
						A	B	C	
VT 1T	1	2.5	1.5	1	6.3	151	145	317	11.5
VT2T	2	3	3	1	8	161.5	187	414	19.5
VT 3T	3	3	4.5	2	7.1	150.5	185	465	22
VT 5T	5	3	7.5	2	9	161.5	241	636	37.5
VT 10T	10	3	15	4	9	207	398	798	65
VT 20T	20	3	30	8	9	215	650	890	152
VT 30T	30	3	45	12	9	350	680	1380	235
VT 50T	50	3	75	20	9	410	965	1950	1092



VC 手拉葫芦

VC CHAIN BLOCK

技术参数 Technical Parameters

Model (kg)	Standard lifting height(m)	Experimental load(ton)	Maximum hand pull	Lifting chain (Number of rows)	Number of rows (millimeter)	Dimensions(M)				Net weight (kg)
						A	B	C	H	
VC 1T	3	1.5	250	1	6	151	172	32	376	12
VC 2T	3	3	335	1	8	175	210	36	470	19
VC2T	3	3	330	2	6	151	159	32	315	16
VC 3T	3	4.5	363	1	10	176	230	46	565	26
VC 3T	3	4.5	370	2	7/8	151	208	46	475	23
VC 5T	3	7.5	360	2	10	189	280	46	688	42
VC7.5T	3	10	410	3	10	188	398	57	688	68
VC 10T	3	12.5	380	4	10	189	463	57	765	70



VD 手拉葫芦

VD CHAIN BLOCK

技术参数 Technical Parameters

Model (kg)	Lifting weight	Standard lifting height(m)	Experimental load(ton)	Lifting chain (Number of rows)	Number of rows (millimeter)	Dimensions(M)			Net weight (kg)
						A	B	C	
VD 1T	1	2.5	1.5	1	6.3	151	145	317	11.5
VD 2T	2	3	3	1	8	161.5	187	414	19.5
VD 3T	3	3	4.5	2	7.1	150.5	185	465	22
VD 5T	5	3	7.5	2	9	161.5	241	636	37.5
VD 10T	10	3	15	4	9	207	398	798	65
VD20T	20	3	30	8	9	215	650	890	152
VD 30T	30	3	45	12	9	350	680	1380	235
VD 50T	50	3	75	20	9	410	965	1950	1092



VD-II 手拉葫芦

VD-II CHAIN BLOCK

技术参数 Technical Parameters

Model (kg)	Standard lifting height(m)	Experimental load(ton)	Maximum hand pull	Lifting chain (Number of rows)	Number of rows (millimeter)	Dimensions(M)				Net weight (kg)
						A	B	C	H	
VD-II 1T	3	1.5	250	1	6	151	172	32	376	12
VD-II 2T	3	3	335	1	8	175	210	36	470	19
VD-II 2T	3	3	330	2	6	151	159	32	315	16
VD-II 3T	3	4.5	363	1	10	176	230	46	565	26
VD-II 3T	3	4.5	370	2	7/8	151	208	46	475	23
VD-II 5T	3	7.5	360	2	10	189	280	46	688	42
VD-II 7.5T	3	10	410	3	10	188	398	57	688	68
VD-II 10T	3	12.5	380	4	10	189	463	57	765	70



HS-T 手拉葫芦

HS-T CHAIN BLOCK

技术参数 Technical Parameters

Model	Capacity (T)	standard lift (m)	Running testload (T)	Min distance between hooks(mm)	Chain pull to lift full load	No.of load chain fall lines	Diameter of load chain(mm)	Dimensions(M)				Net weight (kg)
								A	B	C	D	
HS-TN1	1	2.5	1.5	270	309	1	6	142	122	28	142	10
HS-TN2	2	2.5	3	444	314	2	6	142	122	34	142	14
HS-TN3	3	3	4.5	486	343	2	8	178	139	38	178	24
HS-TN5	5	3	7.5	616	383	2	10	210	162	48	210	36
HS-TN10	10	3	12.5	700	392	4	10	358	162	64	210	68
HS-TN20	20	3	25	1000	392	8	10	510	189	82	210	155



HS-V 手拉葫芦

HS-V CHAIN BLOCK

技术参数 Technical Parameters

Model	Capacity (T)	standard lift (m)	Running testload (T)	Min distance between hooks(mm)	Chain pull to lift full load	No.of load chain fall lines	Diameter of load chain(mm)	Dimensions(M)				Net weight (kg)
								A	B	C	D	
HS-VN1	1	2.5	1.5	270	309	1	6	142	122	28	142	10
HS-VN2	2	2.5	3	444	314	2	6	142	122	34	142	14
HS-VN3	3	3	4.5	486	343	2	8	178	139	38	178	24
HS-VN5	5	3	7.5	616	383	2	10	210	162	48	210	36
HS-VN10	10	3	12.5	700	392	4	10	358	162	64	210	68
HS-VN20	20	3	25	1000	392	8	10	510	189	82	210	155



HSC 手拉葫芦

HSC CHAIN BLOCK

技术参数 Technical Parameters

Model	Capacity (T)	standard lift (m)	Running testload (T)	Min distance between hooks(mm)	Chain pull to lift full load	No.of load chain fall lines	Diameter of load chain(mm)	Dimensions(M)				Net weight (kg)
								A	B	C	D	
HSCN1	1	2.5	1.5	270	309	1	6	142	122	28	142	10
HSCN2	2	2.5	3	444	314	2	6	142	122	34	142	14
HSCN3	3	3	4.5	486	343	2	8	178	139	38	178	24
HSCN5	5	3	7.5	616	383	2	10	210	162	48	210	36
HSCN10	10	3	12.5	700	392	4	10	358	162	64	210	68
HSCN20	20	3	25	1000	392	8	10	510	189	82	210	155



VL 手扳葫芦

VL LEVER HOIST

技术参数 Technical Parameters

Model	Capacity (T)	standard lift (m)	Running testload (T)	Effort Required to Lift Rated Load	Strands of Load Chain	Diameter of Load Chain	Dimensions(M)							Net weight (kg)	Packing Measurement	Extra Weight per Meter of Extra lift
							A	B	C	D	H	L	K			
VL-0.75	0.75	1.5	11.2	140	1	6	145	86	134	38	340	285	27	9.5	37.5*16*18	0.8
VL-3	3	1.5	45	320	1	10	195	115	190	50	490	410	38	18.5	55*18*22.5	2.2
VL-6	6	1.5	75	340	2	10	195	115	242	65	620	410	48	27.5	57*21*23	4.4
VL-9	9	1.5	112.5	360	3	10	195	115	307	81	700	410	54	46	60*42*28	6.6



VA 手扳葫芦

VA LEVER HOIST

技术参数 Technical Parameters

Model	Capacity (T)	standard lift (m)	Running testload (T)	Effort Required to Lift Rated Load	Strands of Load Chain	Diameter of Load Chain	Dimensions(M)							Net weight (kg)	Packing Measurement	Extra Weight per Meter of Extra lift
							A	B	C	D	H	L	K			
VA-0.25	0.25	1	3.75	250	1	4	92	72	85	30	230	160	25	1.8	22*18*11	0.41
VA-0.75	0.75	1.5	11.2	140	1	6	153	86	130	38	295	315	27	7.5	33*18*18.5	0.8
VA-1	1	1.5	15	185	1	6	153	96	130	38	295	315	27	7.5	33*16*13	0.8
VA-2	2	1.5	30	251	1	8	175	105	160	48	385	368	36	15.5	45.5*20*20.5	1.4
VA-3	3	1.5	45	285	1	10	195	112	202	50	450	365	38	16.5	48*22*23	1.8
VA-6	6	1.5	75	385	2	10	196	112	242	65	550	365	48	27	50*23*23	3.6
VA-9	9	1.5	112.5	390	3	10	195	112	315	81	660	365	54	40	48.5*32.5*25	5.4



220V/ 380V 电动葫芦

220V/380V ELECTRIC HOIST

技术参数 Technical Parameters

Model	1t	2T	3T	5t
Supply voltage(v)	220V	220V	220V	220V
Number of rows of chain	1T	2T	3T	5T
Motor power(w)	1500W	1500W	1500W	2000W
Lifting height(m)	3-12m	3-12m	3-12m	3-12m
Lifting speed(m/min)	2.25	1.85	1.1	0.9
Number of rows of chain	1	1	2	2
Supply voltage(kg)	33kg	36kg	42kg	60kg



CD1 钢丝绳 电动葫芦

CD1 WIRE ROPE ELECTRIC HOISTS

技术参数 Technical Parameters

Model(CD1)	1T/6m 1T/9m	2T/6m 2/9m	3T/6m 3T/9m	5T/6m 5T/9m
Mainframe Power	1.5kw	3.0kw	4.5kw	7.5kw
Sports car power	0.2kw	0.4kw	0.4kw	0.8kw
Wire rope diameter	7.7mm	11mm	13mm	15mm
Number of rows of chain	1000kg	2000kg	3000kg	5000kg
Supply voltage(kg)	137kg/145kg	220kg/230kg	280kg/300kg	470kg/495kg



HEIGH SPEED HOIST

20V 小金刚 电动葫芦

技术参数 Technical Parameters

Mudel	Motor power(w)	Wire rope diameter(mm)	Lifting speed(m)	Wire rope diameter(kg)	Net weight(kg)
300/30	1700	5	19	1.72	16.7
500/30	1800	6	13	1.72	2



DHS 电动葫芦

DHS ELECTRIC HOISTS

技术参数 Technical Parameters

MModel	DHS1	DHS2	DHS3	DHS5	DHS10
Rated lifting capacity	1000	2000	3000	5000	10000
Lifting speed(M)	2.25	1.85	1.1	0.9	0.45
Lifting height(M)	3-9	3-9	3-6	3-6	6-10
Dise motor models	YHPE500-4	YHPE500-4	YHPE500-4	YHPE750-4	yhpe750-4
Motor power(W)	500	500	500	750	750
Motor speed(r/min)	1380	1380	1380	1380	1380
Supply voltage(V)	380	380	380	380	380
Supply voltage(kg)	3m-36kg/6m-40kg	45kg/52kg	42kg/50kg	57kg/70kg	115kg/142kg



微型 电动葫芦

MINIELECTRIC HOISY

技术参数 Technical Parameters

Wire rope length/Model	Liftng height	PA200	PA300	PA400	PA600	PA800	PA1000
12m	Single hook	12m	100kg	150kg	200kg	300kg	400kg
	Double hook	61	200kg	300kg	400kg	600kg	800kg
20m	Single hook	20m	70kg	100kg	150kg	200kg	300kg
	Double hook	10m	120kg	150kg	300kg	400kg	600kg
30m	Single hook	30m	30kg	50kg	100kg	150kg	200kg
	Double hook	15m	60kg	100kg	200kg	300kg	400kg



环链 电动葫芦

HHBB ELECTRIC CHAIN HOISY

技术参数 Technical Parameters					
Model	H	A	B	D	E
HHBBO.5-01	530	460	230	288	165
HHBB01-01	650	520	260	300	175
HHBB01-02	680	460	230	288	165
HHBB02-01	800	615	295	430	265
HHBB02-02	835	520	260	300	236
HHBB03-01	845	615	295	430	265
HHBBO3-02	950	615	295	430	320
HHBBO5-02	1030	615	295	450	325
HHBB7.5-03	1380	615	295	505	320



技术参数 Technical Parameters							
Model	Lifting speed (m)	Dimensions(MM)			Chain		
		Motor power (W)	Motor speed (r/min)	Phase number	Supply voltage (v)	Supply voltage (Hz)	specifications
0.5T (Single chain)	7	0.8	1440	3	380	50	Φ6.3
1T (Single chain)	6.8	1.5	1440	3	380	50	Φ 7.1
1T(Double chain)	3.6	0.8	1440	3	380	50	Φ 6.3
2T (Single chain)	6.6	3	1440	3	380	50	Φ10.0
2T (Double chain)	3.5	1.5	1440	3	380	50	Φ7.1
3T (Single chain)	5.6	3	1440	3	380	50	Φ11.2
3T (Double chain)	4.4	3	1440	3	380	50	Φ10.0
5T (Double chain)	2.8	3	1440	3	380	50	Φ11.2
7.5T (Three chains)	1.8	3	1440	3	380	50	Φ11.2



运行式 环链 电动葫芦

HHBB ELECTRIC CHAIN HOISY WITH TROLLEY

技术参数 Technical Parameters					
Model	H	A	B	D	E
HHBBO.5-01	635	460	230	288	165
HHBB01-01	650	520	260	300	175
HHBB01-02	660	460	230	288	165
HHBB02-01	770	615	295	430	265
HHBB02-02	815	520	260	300	236
HHBB03-01	830	615	295	430	265
HHBB03-02	930	615	295	430	320
HHBBO5-02	1015	615	295	430	325
HHBB7.5-03	1200	615	295	505	320



技术参数 Technical Parameters									
Model	Lifting speed (m)	Lifting motors			Dimensions(MM)			Chain	
		Motor power (W)	Motor speed (r/min)	Phase number	Supply voltage (v)	Frequency (Hz)	Motor power (W)	Running speed (r/min)	specifications
0.5T (Single chain)	7	0.8	1440	3	380	50	0.4	11	Φ6.3
1T (Single chain)	6.8	1.5	1440	3	380	50	0.4	11	Φ 7.1
1T(Double chain)	3.6	0.8	1440	3	380	50	0.4	11	Φ 6.3
2T (Single chain)	6.6	3	1440	3	380	50	0.4	11	Φ10.0
2T (Double chain)	3.4	1.5	1440	3	380	50	0.4	11	Φ7.1
3T (Single chain)	5.4	3	1440	3	380	50	0.4	11	Φ11.2
3T (Double chain)	3.3	3	1440	3	380	50	0.4	11	Φ10.0
5T (Double chain)	2.8	3	1440	3	380	50	0.75	11	Φ11.2
7.5T (Three chains)	1.8	2*3.0	1440	3	380	50	0.75	11	Φ11.2



铝壳 提升机

KCD ELECTRIC WINCH

技术参数 Technical Parameters								
Model	How to use	The rated voltage(V)	MMotor power(Kw)	Number of rows of chain kkg	Lifting speed (m/min)	Lifting height (m)	Wire rope diameter (mm)	Net weight (kg)
KCD-K1	Single rope	380	1.7	500	16	30	1.7	30
500-1000	Double rope			1000	8	15		
KCD-K1	Single rope	220	3.0	500	16	12	3.0	30
500-1000	Double rope			1000	8	6		
KCD-K1	Single rope	380	2.2	750	14	12	2.2	38
750-1500	Double rope			1500	7	6		
KCD-K1	Single rope	220	4.0	750	14	12	4.0	38
750-1500	Double rope			1500	7	6		

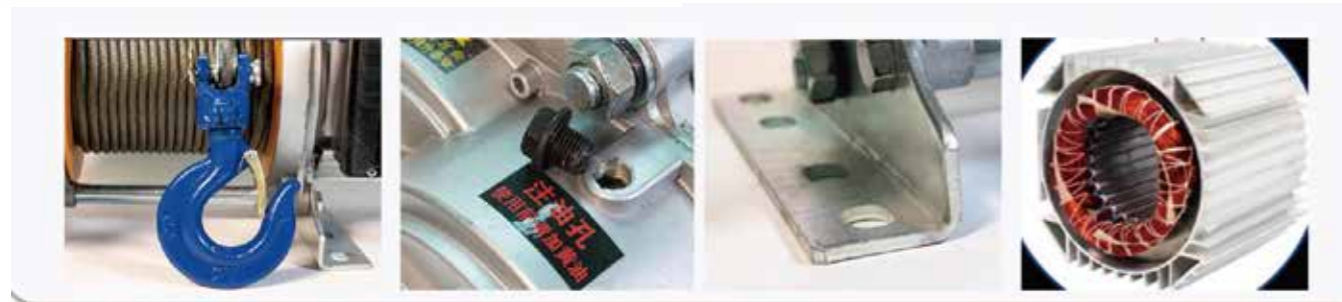

压盘 提升机

ELECTRIC CLUBTH WINCH

技术参数 Technical Parameters	
额定载重/ rated load:	500KG/1000KG
提升速度/ Improve speed:	24m/min
钢丝长度/ Length of wire:	30米(可加长配至100米) 30 meters (can be extended to 100 meters)
钢丝型号/ Wire gauge:	直径6mm Diameter 6mm
电机功率/ Motor power:	3.0KW
电极等级/ Electrode grade:	F级
整机重量/ Weight of the machine:	42KG
产品尺寸/ Product size:	620*270*290

技术参数 Technical Parameters	
额定载重/ rated load:	750KG/1500KG
提升速度/ Improve speed:	24m/min
钢丝长度/ Length of wire:	30米(可加长配至100米) 30 meters (can be extended to 100 meters)
钢丝型号/ Wire gauge:	直径6mm Diameter 6mm
电机功率/ Motor power:	4.0KW
电极等级/ Electrode grade:	F级
整机重量/ Weight of the machine:	42KG
产品尺寸/ Product size:	620*270*290

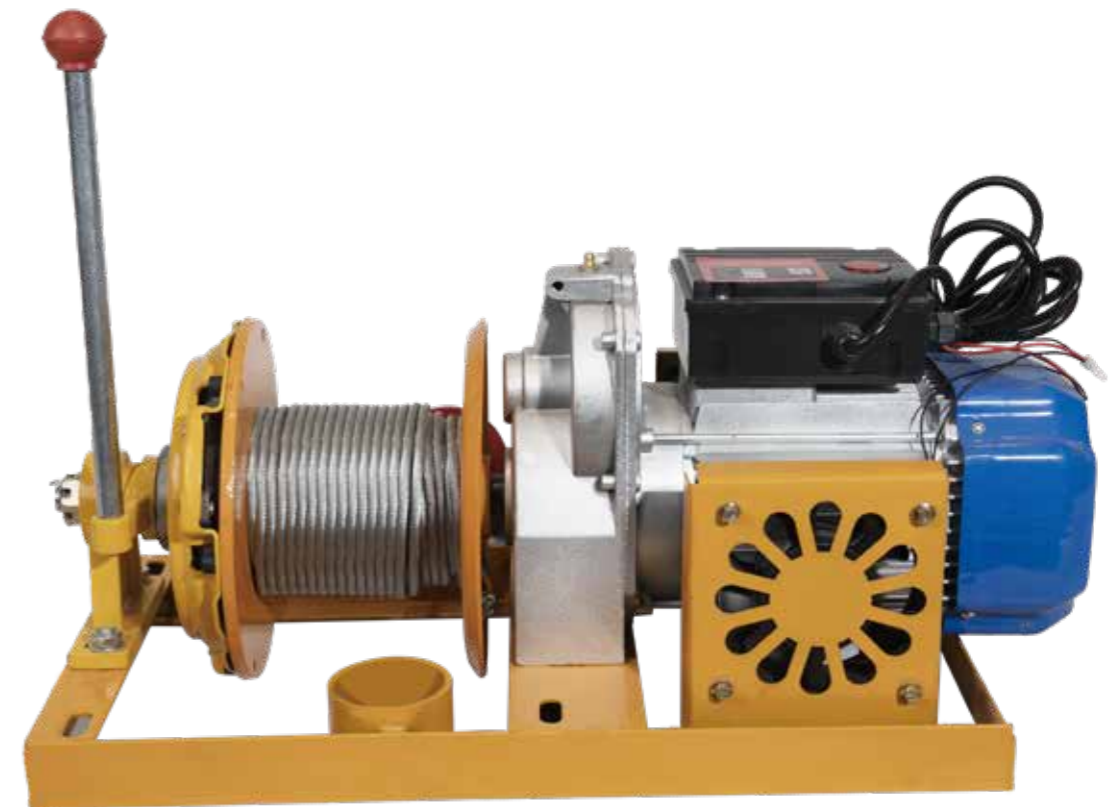

JEEP 绞盘

JEEP WINCH

技术参数 Technical Parameters

型号/ Model:	2000磅	3000磅	3500磅	4000磅	4500磅	6000磅	9500磅	12000磅
输出电压/ Output voltage:	12/24V	12/24V	12/24V	12/24V	12/24V	12/24V	12/24V	12/24V
水平牵引/ Horizontal traction:	400KG	600KG	800KG	1000KG	1300KG	2000KG	3000KG	4000KG
垂直吊重/ vertical lifting:	200KG	300KG	400KG	500KG	650KG	1000KG	1300KG	1500KG
控制方式/ Control mode:	手动/Manual	手动/Manual	手动/Manual	手动/无线 Manual/wireless	手动/无线 Manual/wireless	手动/无线 Manual/wireless	手动/无线 Manual/wireless	手动/无线 Manual/wireless
空载速度/ No load speed:	6m/min	6m/min	6m/min	6m/min	6m/min	6m/min	6m/min	6m/min
钢丝绳/ steel wire rope:	4mm*6m	5mm*6m	5mm*8m	5mm*10m	5mm*10m	7.7mm*14m	10mm*24m	10mm*24m
电机材质/ steel wire rope:	全铜电机 All-copper motor	全铜电机 All-copper motor	全铜电机 All-copper motor	全铜电机 All-copper motor	全铜电机 All-copper motor	全铜电机 All-copper motor	全铜电机 All-copper motor	全铜电机 All-copper motor
产品毛重/ Gross weight of the product:	6KG	7KG	8KG	9KG	10KG	24KG	36KG	38KG
外形尺寸mm/ Dimensions in mm:	286*100*105	399*100*105	340*110*112	353*110*112	332*116.5*115	415*160*217	529*160*217	527*160*217



3项电 提升机

3P WINCH

技术参数 Technical Parameters

电机型号/ Motor model	起吊方式/ Hoisting method	钢丝绳长m/起重量kg Wire rope length m/lifting weight kg			起升速度 Hoisting speed	电机功率 Motor power	电机自重 Motor weight	螺丝孔安装距离 Screw hole installation distance	电机尺寸 Motor size
		30m	60m	100m					
1 T	单绳 Single rope	30m 500kg	60m 400kg	100m 250kg	14米/分 14 meters/minute	1.5kw	47kg(30米) 61kg(60米) 65kg(100米)	27.5*17cm (长*宽) length*width	55*27*38cm (长*宽*高) length*width*height
	双绳 Double rope	15m 1000kg	30m 800kg	50m 500kg	7米/分 7 meters/minute				
1.5 T	单绳 Single rope	30m 750kg	60m 600kg	100m 350kg	16米/分 16 meters/minute	1.5kw	75kg(30米) 85kg(60米) 98kg(100米)	33.5*18cm (30/60米) (100米)	65*27*38cm (30/60米) (100米)
	双绳 Double rope	15m 1500kg	30m 1200kg	50m 700kg	8米/分 8 meters/minute				
2 T	单绳 Single rope	30m 1000kg	60m 800kg	100m 500kg	16米/分 16 meters/minute	3kw	135kg(30米) 145kg(60米) 158kg(100米)	45*20cm (长*宽) length*width	85*33*40cm (长*宽*高) length*width*height
	双绳 Double rope	15m 2000kg	30m 1600kg	50m 1000kg	8米/分 8 meters/minute				



卷扬机

3P ELECTRIC WINCH

技术参数 Technical Parameters

Model	1T		2T		3T		5T					
How to use												
The rated voltage(v)	380		380		380		380					
Motor power(kw)	500	1.5	1000	1000	3.0	2000	1500	4.5	3000	2500	7.5	5000
Number of rows of chain(kg)	16	8	16	8	16	8	16	8	16	8		
Lifting speed(m/min)												
Lifting height(m)	30-100		30-100		30-100		30-100					
shengzhi(mm)	8		11		13		15					
Net weight(kg)	80		130		160		260					
Steel wire rope(#)	7.7#		11#		13#		15#					
Overall length(mm)	770		830		930		1080					
Channel steelLength(mm)	530		600		650		750					
Height(mm)	410		520		540		600					
Width9(mm)	310		430		450		510					
Distance from centre(mm)	260		260		290		310					



CD-K1 ELECTRIC WINCH

二代提升机

技术参数 Technical Parameters

电机型号/ Motor model	电机电压 Motor voltage	电机功率 Motor power	钢丝绳长 Length of wire rope	起升重量 Lifting weight		
1 T	220V	3.0kw	1-100m	单绳16m Single rope16m	单绳0.5T Single rope0.5T	6mm
				双绳8m Double rope8m	双绳1T Double rope1T	
1 T	380V	1.7kw	1-100m	单绳16m Single rope16m	单绳0.5T Single rope0.5T	6mm
				双绳8m Double rope8m	双绳1T Double rope1T	



手拉跑车

PULL THE CART

技术参数 Technical Parameters

Capacity (T)	I-BEAM(mm)		Dimensions(mm)					Netweight (kg)	Carton Size (mm)
	M	A	B	C	E	H	F		
1T*5M	75-125mm	258	250	214	11	118	1.5-3	132	305*160*175
2T*5M	100-150mm	284	270	227	14	125	1.5-3	17.8	330*170*205
3T*5M	100-150mm	312	315	304	8	165	1.5-3	26.1	390*200*235
5T*5M	125-175mm	365	358	334	21	183	1.5-3	39.4	440*235*270
10T*5M	110-200mm	458	430	434	36	250	1.5-3	75	590*310*400
20T*5M	110-300mm	595	518	524	45	324	1.5-3	190	610*415*525



坦克搬运车

TANK TRANSPORTER

技术参数 Technical Parameters

型号	钢轮	重量KG	钢芯胶轮	重量KG	PU轮	重量KG	塑料轮	重量KG	轮子数量	包装尺寸
6T	93	13.3	82	11.5	100	11.5	69	9	4	32/22/12
8T	130	20	116	16.3	145	16.5	98	13	6	42/22/12
12T	180	24	157	21.5	190	21.3	133	16.8	8	51/23/12
15T	195	29	177	23	205	24.8	150	19	9	43/32/12
18T	255	36.5	230	30	275	30	193	23.4	12	51/31/12
24T	360	46	310	38	390	45.5	260	34.5	16	51/40/12
转向	钢轮	重量 KG	钢芯胶轮	重量KG	PU轮	重量KG	塑料轮	重量KG	轮子数量	包装尺寸
6T	128	17	120	14.5	135	15	108	13	4	32/22/12
8T	172	22.5	160	18.7	184	20	143	16.3	6	42/22/12
12T	233	33	216	24	245	26.5	192	21	8	43/32/12
15T	255	38	231	27	270	28	204	23	9	43/32/12
18T	370	47	336	41	385	43	300	32.5	12	51/31/12
24T	525	65	498	54.5	565	56	450	42	16	620/420/140
万向	钢轮	重量 KG	PU轮	重量KG					轮子数量	包装尺寸
3T	210	19.5	225	18.5					3	
4T	288	29	305	27.5					4	580/455/140
5T	315	36	330	34					5	620/520/140



剪式千斤顶

WO SHI JACKING SCISSOR JACKS

技术参数 Technical Parameters

Model	Minimum height	Maximum height	Net weight
2T	135mm	345mm	6.7kg
3T	135n1	470n11	22kg



技术参数 Technical Parameters

Model	Minimum height/ Maximum height	Net weight
0.8T	8.5cm/27cm	1.3kg
1T	9cm/33cm	1.55kg
1.5T	9cm/36cm	1.76kg
2T	10.5cm/42cm	2.65kg
3T	12cm/46cm	3.4kg



气动千斤顶

PNEUMATIC JACKS

技术参数 Technical Parameters

Model	30T	50T	60T	80T	100T	120T
Minimum height	165mm	165mm	190mm	205mm	205mm	205mm
Maximum height	340mm	330mm	400mm	385mm	385mm	385mm
Height with pads	460mm	450mm	520mm	505mm	505mm	505mm
Net weight	27kg	35kg	40kg	60kg	75kg	90kg
Number of rows of chain	15/30T	25/50T	30/60T	40/80T	50/100T	60/120T
Handle length	850mm	1130mm	1130mm	1130mm	1250mm	1250mm



螺旋 千斤顶

SCREW JACKS

技术参数 Technical Parameters

Model	Lifting height(cm)	Maximum height(cm)	Minimum height(cm)	Diameter of top plate(cm)	Bottom diameter(cm)	Net weight(kg)
3.5T	11.7	33	22	4.1	10	4.85
5T	13.7	37	25	4.9	11.5	5.5
8T	14.2	37.8	25	4.9	11.2	5.62
10T	15.2	42	28	5.3	11.8	7.29
16T	18.3	49.5	33	5.6	12	9.52
20T	18.3	49.5	33	6.1	12.8	10.68
25T	13.1	39	28	6.1	12.8	9.85
32T	22	58.5	39.5	7.1	14	16.84
50T	25.5	68.5	45	9.4	18.3	31.53
100T	20	65.5	45.2	9.4	20.3	63.53



手摇 绞车

HAND WINCH

技术参数 Technical Parameters

Product model 产品型号	1200LB	1800LB	2600LB
Rated load capacity/lb 额定载重量/磅	1200	1800	2600
Lateral traction/KG 横向牵引力/KG	500	800	1100
Longitudinal pull/KG 纵向拉力/KG	150	300	500
Speed ratio 速比	4:1	4:1	8:1
Manual force/N 手摇力/N	180	190	190
Wire diameter/mm 钢丝绳直径/mm	4	5	6
Wire rope length/m 钢丝绳长度/m	5-30	5-40	5-40
Main dimensions/mm 主要尺寸/mm	A	Φ48	Φ60
	B	Φ134	Φ180
	C	51	60
	D	157	190
	E	Φ27	Φ27
	F	273	288
	G	110	110
	H	156	203
	J	136	195
R	250	280	280
Weight/KG 重量/KG	3.8	8	10.2

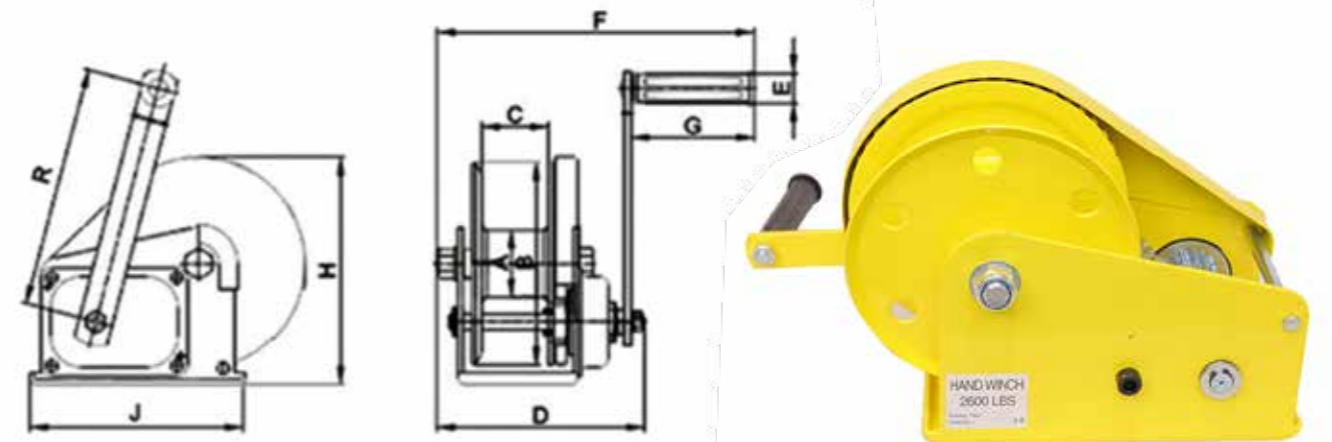

G80 链条参数

G80 CHAIN PARAMETERS

技术参数 Technical Parameters

Project Number 项目编号	WLL (T)	B.L (T)	D (mm)	T (mm)	B1(mm) minimum B1(mm)最小值	B2(mm)Maximum B2(mm)最大值
6mm	1.12	4.48	6±0.24	18±0.5	7.8	22.2
7mm	1.5	6	7±0.28	21+0.6	9.1	25.9
8mm	2	8	8+0.32	24±0.7	10.4	29.6
10mm	3.15	12.6	10+0.4	30+0.9	13	37
13mm	5.3	21.2	13+0.52	39±1.2	16.9	48.1
16mm	8	32	16+0.64	48±1.4	20.8	59.2
18mm	10	40	18+0.9	54+1.6	23.4	66.6
20mm	12.5	50	20+1.0	60+1.8	26	74
22mm	15	60	22±1.1	68+2.0	28.6	81.4
26mm	21.2	84.8	26±1.3	78±2.3	33.8	96.2
32mm	31.5	126	32+1.6	96±2.9	41.6	118



PERMANENT MAGNET CHUCK

永磁吸盘

技术参数 Technical Parameters

Model 型号	Rise/升 mm	Tile/瓦 mm	Ha/哈 mm	Luo/罗 mm	Weight/重量 kg	Rated lifting capacity 额定起重重量kg	Maximum pull-off force 最大拉脱力kg
100KG	94	62	72	160	3	100	160
300KG	163	92	95	205	9	300	205
600KG	208	114	115	220	19	600	220
1000KG	256	134	140	250	34	1000	250
2000KG	442	154	166	360	82	2000	360
3000KG	532	170	192	490	120	3000	490
5000KG	612	233	286	720	290	5000	720
6000KG	808	233	286	920	385	6000	920



钢板 起重钳子

STEEL PLATE LIFTING PLIERS

技术参数 Technical Parameters

Model	Rated load	Range of openings	Self-weight
PDB-1T	1T	0-30mm	3.5kg
PDB-2T	2T	0-40mm	5kg
PDB-3.2T	3.2T	0-45mm	6kg
PDB-5T	5T	0-50mm	7.5kg
PDB-8T	8T	0-100mm	22kg
PDB-10T	10T	0-125mm	33kg



钩子 系列

HOOK SERIES

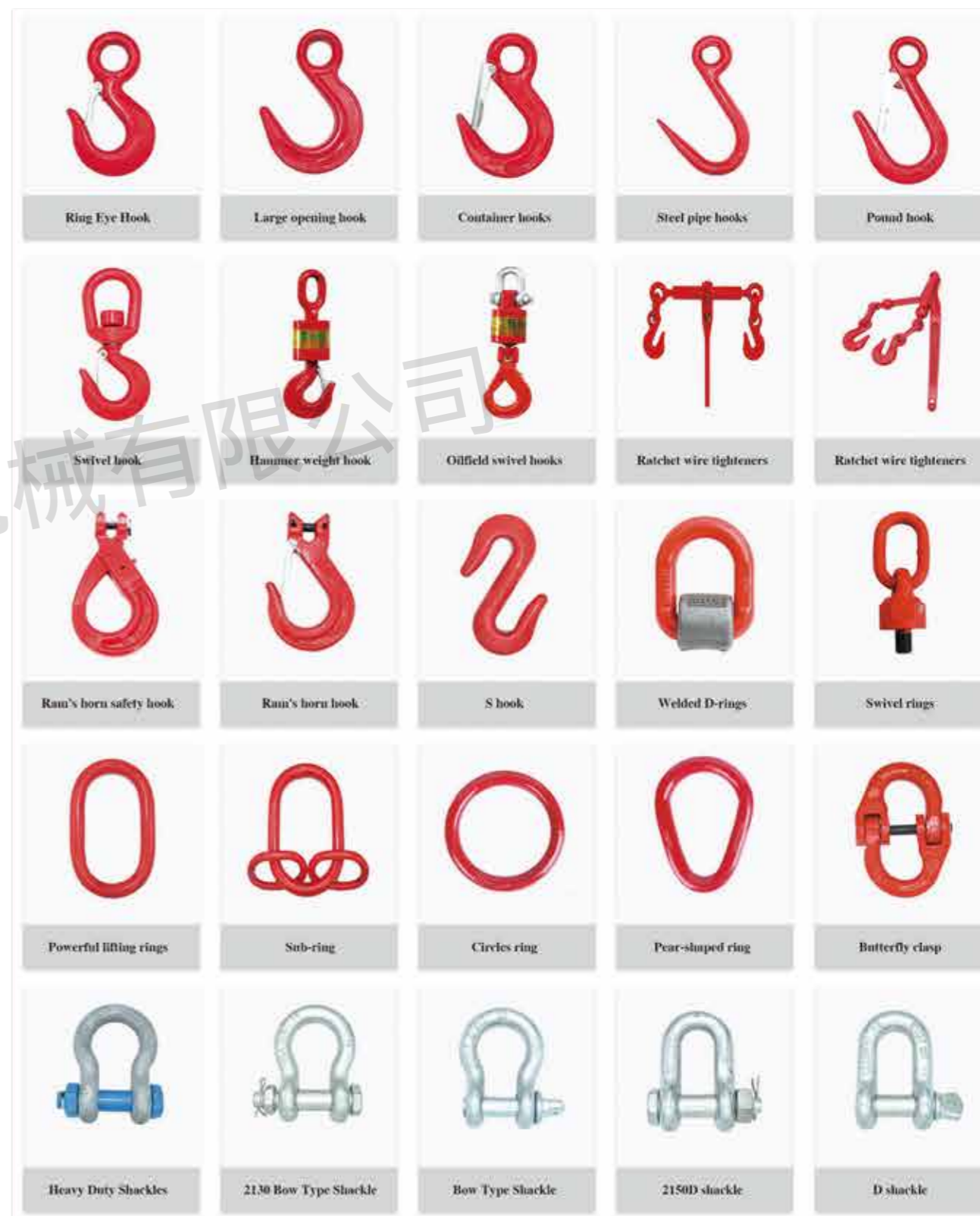

保定钧运起重机械有限公司