

**BOMPDU**  
博 姆 电 子

# Wuxi Bom

Electronics Technology Co., Ltd

Sincerity • Cooperation

Win-Win • Future

# Contents

**01**

**Company Profile**

**02**

**Intelligent 2nd-Generation  
PDU Introduction**

**03**

**Intelligent 2nd-Generation  
PDU Assembly**

**04**

**Intelligent 2nd-Generation  
PDU Monitoring Protocol**

**05**

**Other Communication  
Protocols**

# Company Profile

---

01



# WELCOME

## ——企业简介——

Wuxi BOM Electronic Technology Co., Ltd. Located at Building A3, Tian'an Smart City, No.228 Linghu Avenue, Xinwu District, Wuxi, Jiangsu. A high-tech enterprise integrating R&D, production and sales, focusing on industrial control intelligent products and integrated circuits. We satisfy diverse enterprise customer demands, cooperate with manufacturers, and win wide recognition.

With rich design and manufacturing experience, we emphasize R&D and innovation to develop core technologies. Adhering to sincerity first, quality priority, customer supremacy, we provide reliable products and professional services. We have long experience in data centers and smart homes, with pilot R&D and mass production capacity, stable batch supply, and complete after-sales support.

“

6G: We Hold Dreams in Our Hearts

Setting Sail/Reaching New Heights

”

## ◆ PDU Product Categories ◆

### ● Smart Meter Products

- Intelligent 2nd-Gen PDU
- Intelligent 1st-Gen PDU
- IP-PDU

### ● 485 Meter Products

- Three-Phase 485
- 1U、1.5U485

### ● Voltmeter & Ammeter Products

- Voltmeter & Ammeter
- Energy Meter



The 2nd Generation Intelligent PDU

The 2nd Generation Intelligent PDU is an intelligent PDU product that supports single-phase and three-phase input metering as well as output metering and control. It can transmit electrical parameters including input and output voltage, current, power and electric energy, as well as alarm status, to the power and environment monitoring platform via TCP/IP or RS485 communication.



The 1st Generation Intelligent PDU

The 1st Generation Intelligent PDU is an intelligent PDU product capable of single-phase input metering and output metering & control. It can transmit electrical parameters such as input voltage, current, power and electric energy, as well as alarm status, to the power and environment monitoring platform via TCP/IP or RS485 communication.



IP-PDU

IP-PDU is an economical intelligent PDU that supports single-phase input metering and output metering & control. It can transmit electrical parameters such as input voltage, current, power and energy, as well as alarm status, to the power and environment monitoring platform over the network.



Three-Phase 485-PDU

Three-Phase 485-PDU is a 485 PDU meter module capable of collecting AC single-phase and three-phase input signals. It can transmit electrical parameters such as input voltage, current, power and electric energy, as well as alarm status, to the power and environment monitoring platform via RS485 communication.



1U485 PDU

1U485 PDU is a 485 PDU meter module supporting single-phase input metering. It can transmit electrical parameters including input voltage, current, power and electric energy, as well as alarm status, to the power and environment monitoring platform via RS485 communication.



1.5U485 PDU

1.5U485 PDU is a 485 PDU meter module supporting single-phase input metering. It can transmit electrical parameters such as input voltage, current, power and electric energy, as well as alarm status, to the power and environment monitoring platform via RS485 communication.



Voltage & Current Meter

Voltage & Current Meter is a meter module supporting single-phase input metering, which can display input voltage and current on a digital tube.



Energy meter

The energy meter is a meter module supporting single-phase input metering, which can display input voltage, current, power and electric energy on the screen.

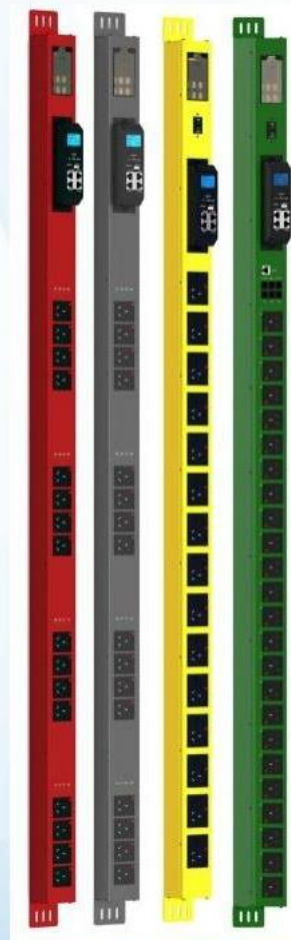

# Intelligent 2nd-Gen PDU Product Introduction

---



02

### ◆ Mainboard Interfaces ◆

- |   |                                 |
|---|---------------------------------|
| 1.LCD Display (2 / 2.8 inch)                    | 10.RS485 Cascading Interface    |
| 2.Run Indicator                                 | 11.RS485 Cascading Interface    |
| 3.Alarm Indicator                               | 12.Door Contact Alarm Interface |
| 4.Page Key                                      | 13.Temperature & Humidity       |
| 5.Reset (short press) /<br>Restore (long press) | Sensor Interface                |
| 6.Page Key                                      | 14.Smoke Alarm Interface        |
| 7.USB Upgrade Port                              |                                 |
| 8.RS485 Water Leak Sensor Interface             |                                 |
| 9.10/100M Ethernet Port                         |                                 |

Note: Use interfaces properly to avoid equipment damage caused by wrong insertion.

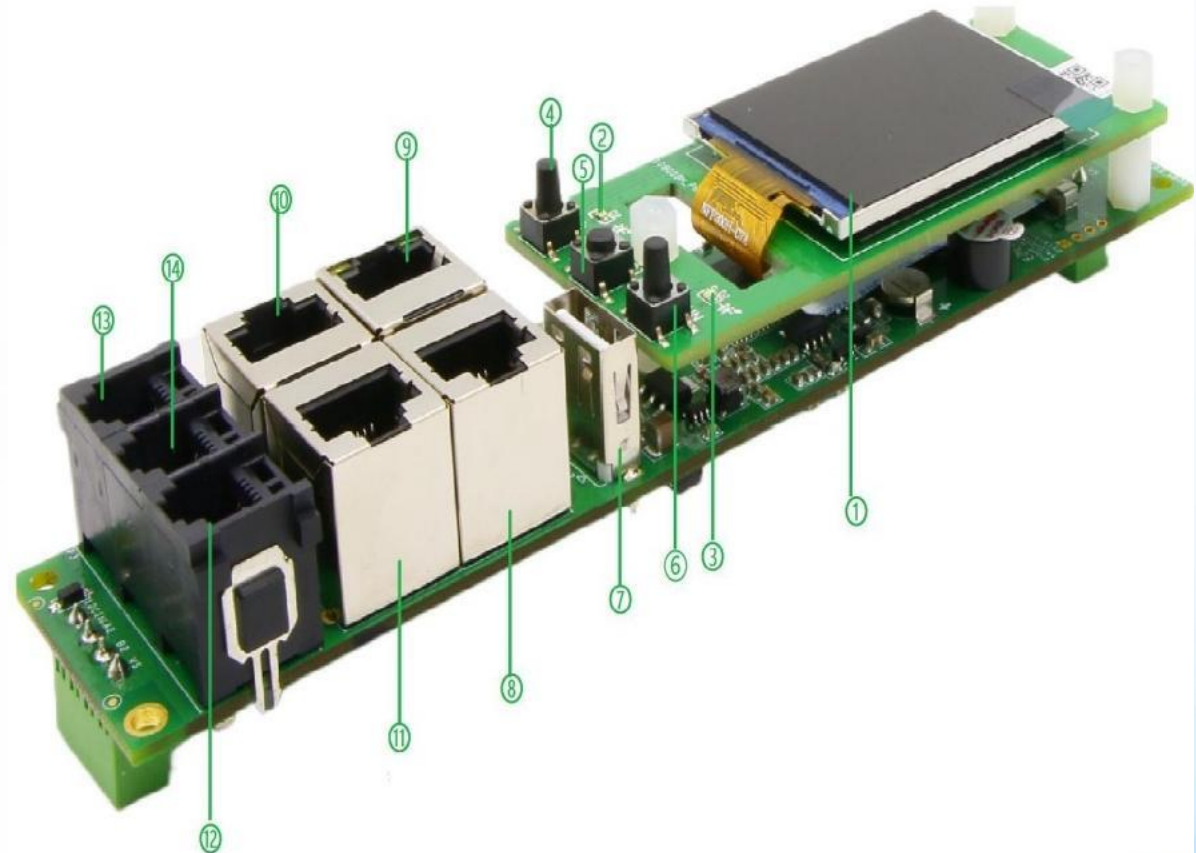

### ◆ Input Metering Interfaces ◆

- |   |   |
|---|---|
| 1. Slave Board Interface                | 9. N Line Temperature Sensor Interface  |
| 2. Leakage Transducer Interface         | 10. L Line Temperature Sensor Interface |
| 3. Phase C Current Transducer Interface | 11. Surge Protection Module Interface   |
| 4. Phase B Current Transducer Interface | 12. N Line Input                        |
| 5. Phase A Current Transducer Interface | 13. Phase A Input                       |
| 6. Slave Board Interface                | 14. Phase B Input                       |
| 7. 12V Power Supply Interface           | 15. Phase C Input                       |
| 8. PE Line Temperature Sensor Interface |   |

Note: Use interfaces properly to avoid equipment damage caused by wrong insertion.

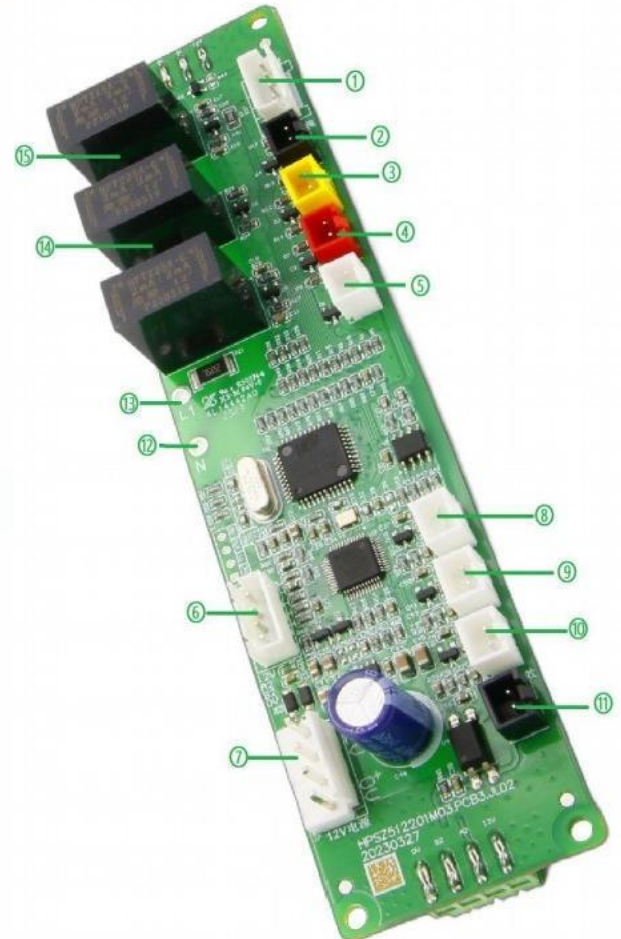

## ❖ Slave Board Interfaces ❖

- |                                 |                        |
|---------------------------------|------------------------|
| 1. Slave Cascading Interface    | 8.LIN2 Live Wire Input |
| 2.Slave Cascading Interface     | 9.OUT4 Interface       |
| 3.Light Board Interface         | 10.OUT3 Interface      |
| 4.Slave Address Code DIP Switch | 11.OUT2 Interface      |
| 5.LIN1 Live Wire Input          | 12.OUT1 Interface      |
| 6.LIN3 Live Wire Input          | 13.N Line Input        |
| 7.LIN4 Live Wire Input          |                        |

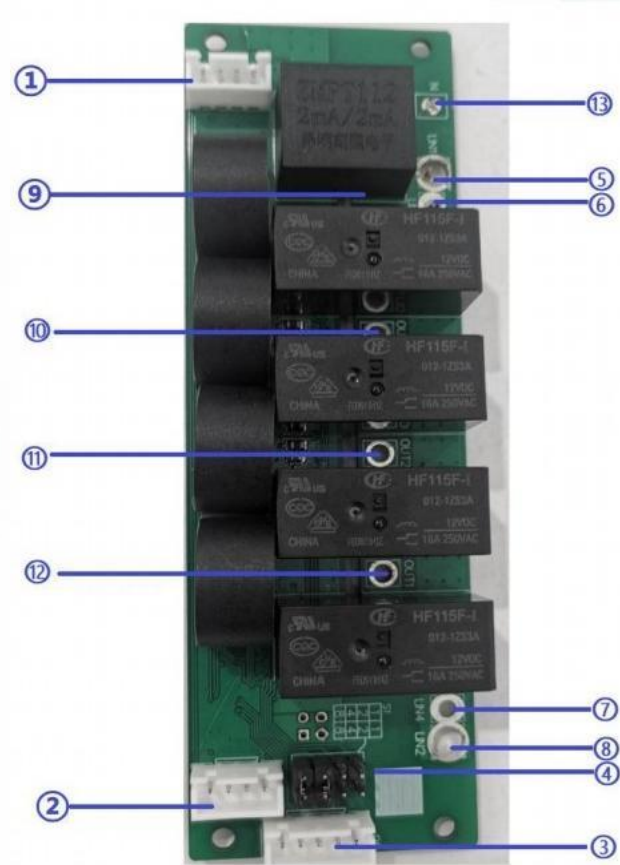

### ❖ Function List ❖

#### ● Single/Three-Phase AC Input – Total Monitoring

- 220V single-phase or 380V three-phase input
- 0–63A input current metering
- 5‰ metering accuracy; dual-level alarm & customizable thresholds
- Single/three-phase mode switching

#### ● Output Metering & Control – Per-Outlet Monitoring & Control

- Three modes: metering only, control only, metering + control
- Up to 0–32 configurable outputs; max 16A per outlet (max 32A for 4 channels per slave); ±1% accuracy
- Per-outlet voltage, current, power, energy monitoring, alarm and switch control
- Remote switch, timer switch, sequential power-on

#### ● Environmental Parameter Collection

- 1× temperature/humidity sensor, 3× temperature sensor; customizable alarm thresholds
- 1× smoke, 1× water leak, 1× door contact sensor

### ❖ List of Features for Smart 2.0 ❖

- Network Topology: 1 master+9 slaves cascading
- Output Configuration: 0–32 outputs
- Multi-language: Chinese/English/**Russian (\*)**
- Hot-swap: main meter can be replaced with power on
- IP Assignment: static IP / DHCP
- IP Type: IPv4 / **IPv6**
- Communication:
  - MODBUS-RTU / MODBUS-TCP
  - SNMP v1/v2/**v3 (AES256)**
  - HTTP**(S)** / SSH / TELNET
- Network Security:
  - **HTTPS/firewall & IP filtering**
  - **RADIUS authentication (\*)**

- **Log System**: alarm, data, control, power-on logs
- Active Alarm Push:
  - SNMP Trap / **Syslog**
  - SMTP/**SMTPS (\*)**
- Local LCD: TFT color screen, portrait/landscape switchable
- Time Management: manual calibration + NTP synchronization
- Upgrade System: USB drive upgrade / network upgrade
- USB Interface: firmware upgrade / **log export (\*)**

#### Notes:

1. \*Features for next version
2. Green marked: product advantages

### ❖ Communication Protocols ❖

#### ● Networking & Access Interfaces

- TCP/IP Network Access
- RS485 Access

#### ● RS485 Communication

- MODBUS-RTU Protocol

#### ● TCP/IP Network Access

- MODBUS-TCP Protocol
- SNMP Protocol (v1/v2c/v3)
- SSH/TELNET command line query & control
- HTTP(HTTPS)

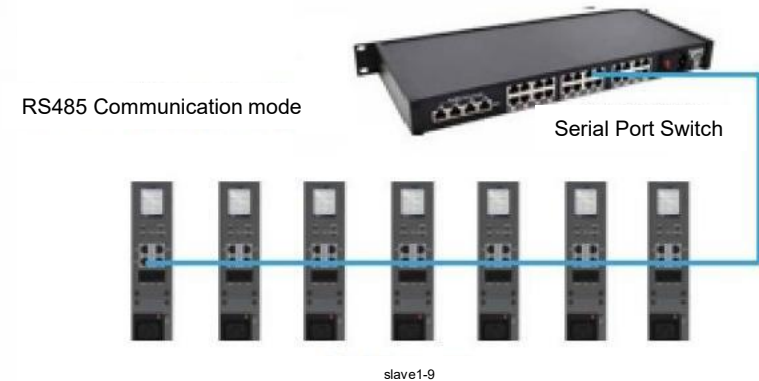
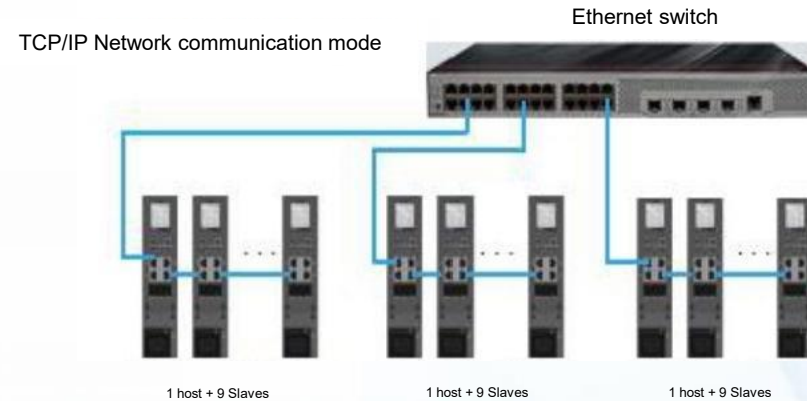

## ❖ Intelligent 2nd-Gen PDU I/O Combination ❖

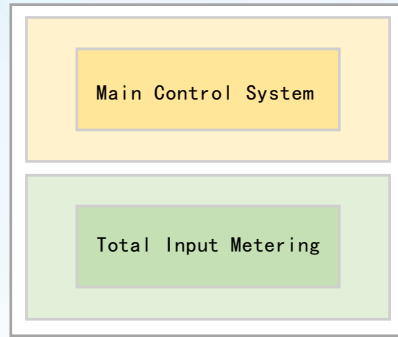

Total Input Metering

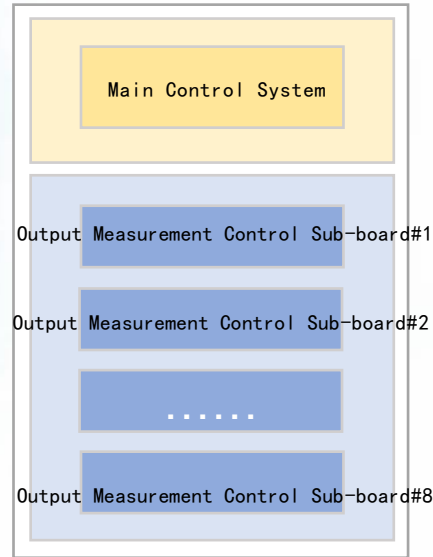

Per-Outlet Metering & Control

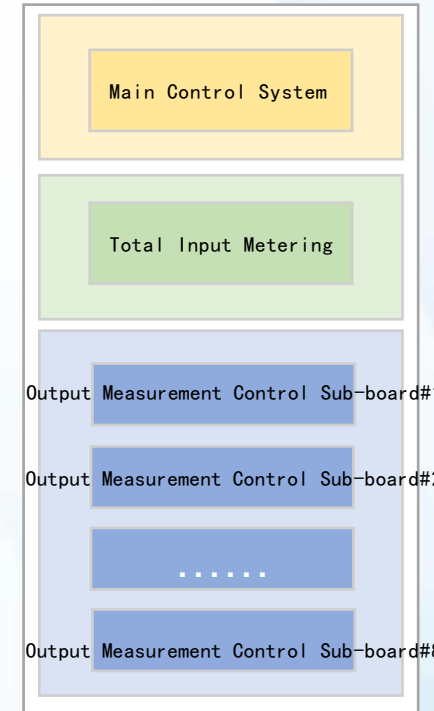

Total input measurement  
Per-Outlet Metering & Control

## ◆ 2nd-Gen Slave Board Output Solutions ◆

- Standard slave boards meet most customer needs. Extended versions can be developed based on standard design.

Function	Metering-Only	Metering + Control	Option 3	Option 4
Per-outlet voltage / current / power detection	●	●	●	●
Customizable voltage & current alarm thresholds for outputs	●	●	●	—
Per-outlet on / off / reboot control	—	●	●	●
1-channel max 16A, 4-channel max 32A	●	●	—	—
1-channel max 16A, 4-channel max 64A	—	—	●	—
1-channel max 23A, 4-channel max 32A	—	—	—	●

# Intelligent 2nd-Gen PDU – Full Assembly

---

03



## ◆ Full Assembly ◆

### ● AC Input

- 1P Input
- 3P Input 【3-phase 4-wire / 3-phase 5-wire】

### ● Power Supply Section

- In three-phase input, Phase A supplies the power module and the whole system.

### ● High-Voltage Section

- Input Metering: 3 live wires to L1/L2/L3, N to neutral, IA/IB/IC to corresponding current transformers
- Output Metering & Control: 1 input, 4 outputs per slave board

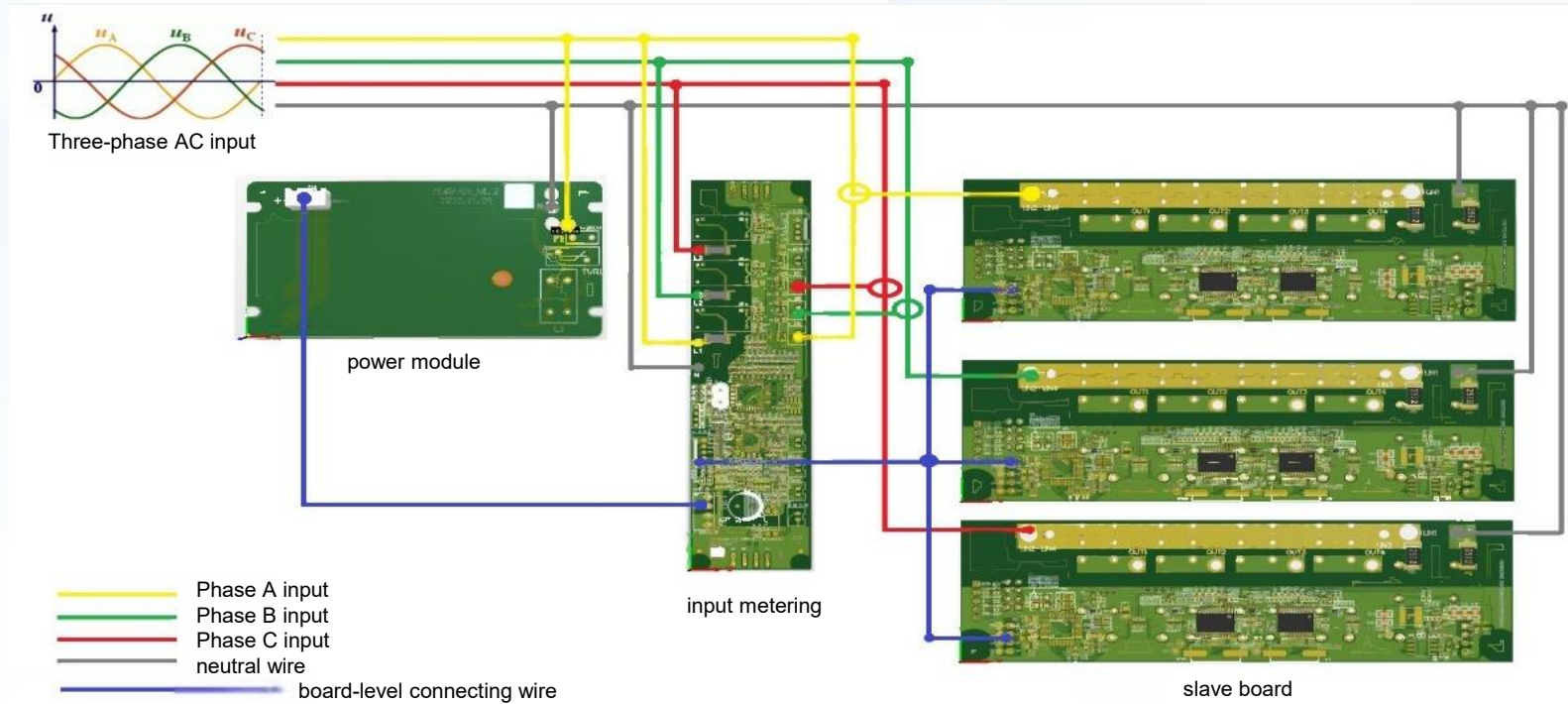

## ◆ Full Assembly ◆

### ● Low-Voltage Communication Section

- Metering board and slave boards connected via RS485 bus
- Slave boards cascaded in daisy-chain mode
- Each slave board requires a unique address code
- Slave address ADDR = number of outlets / 4

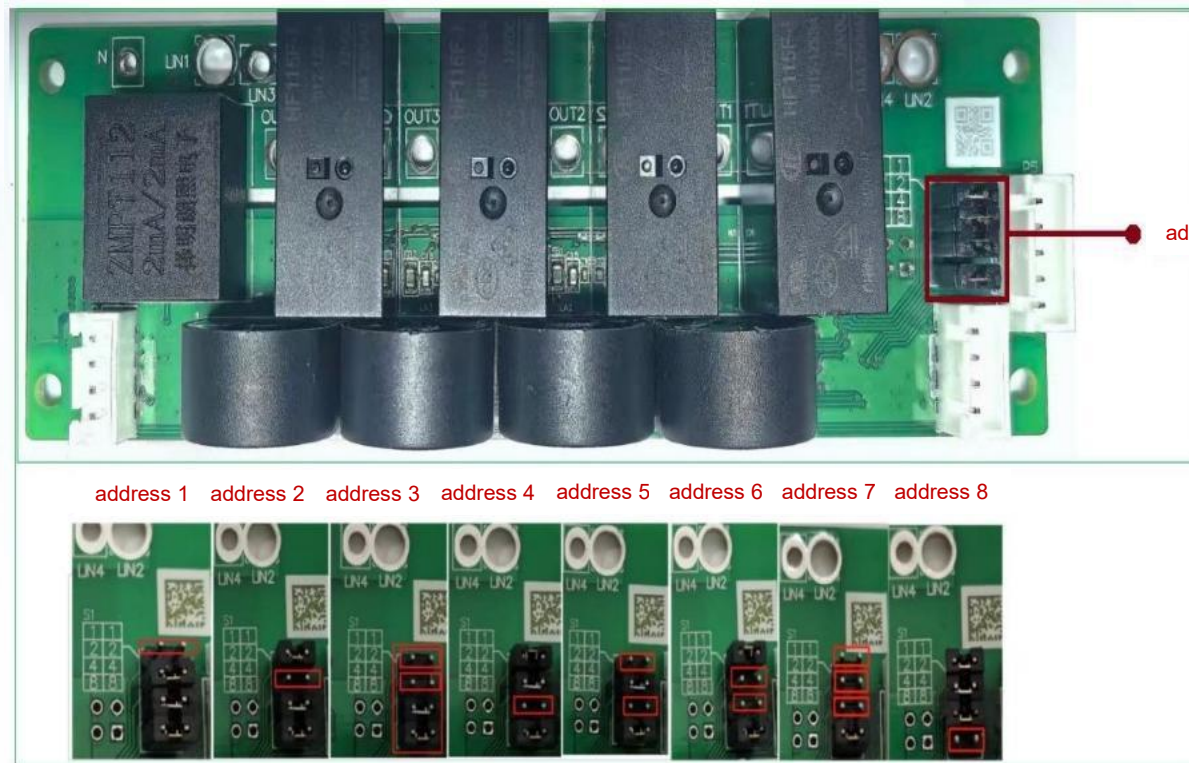

## ◆ Full Assembly ◆

### ● PDU WEB Login

- Power on the PDU
- Obtain IP from the LCD (default: 192.168.1.192)
- Enter IP in Chrome/IE browser to open the login page
- Default account: admin / admin

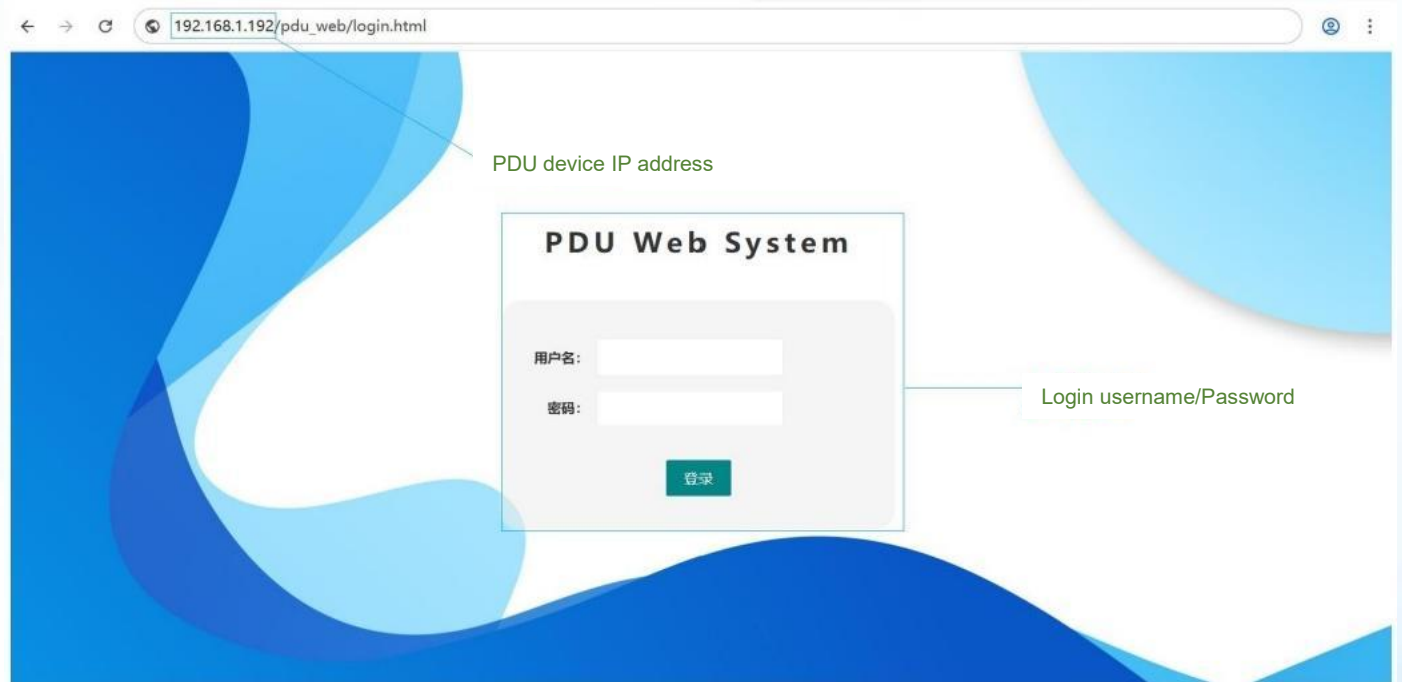

## ◆ Full Assembly ◆

### Full Configuration PDU configuration includes:

- Number of output outlets
- Language selection
- Input type: single-phase or three-phase
- Per-outlet monitoring & control selection

### Full Configuration PDU Admin URL:

192.168.1.192/pdu\_web/damin.html, therein 192.168.1.192 is the address of the PDU device.

The image displays three screenshots of the PDU configuration web interface, each with a callout box explaining a specific feature:

- Top Screenshot:** Shows the 'Number of configured branches' setting. The URL is [192.168.1.192/pdu\\_web/admin.html](http://192.168.1.192/pdu_web/admin.html). The 'Number of configured branches' is set to 12.
- Middle Screenshot:** Shows the 'Language selection' setting. The URL is [192.168.1.192/pdu\\_web/admin.html](http://192.168.1.192/pdu_web/admin.html). The language is set to '中文' (Chinese).
- Bottom Screenshot:** Shows the 'Configure the slave board type for input 1P&3P' setting. The URL is [192.168.1.192/pdu\\_web/admin.html](http://192.168.1.192/pdu_web/admin.html). The 'Input phase' is set to '单相' (Single phase) and the 'Module type' is set to '计量+控制' (Metering+Control).

## ❖ Equipment Deployment ❖

### Configure PDU according to on-site requirements:

- Network settings: IP mode (static/DHCP), subnet mask, gateway, DNS
- Cascade settings: mode and address configuration
- Others: NTP time synchronization



The screenshot shows the 'PDU Web System' interface with the '网络设置' (Network Settings) tab selected. The left sidebar contains menu items: 账户管理, 分组管理, 密码修改, 设备部署 (highlighted), 全局设置, 阈值设置, and 电能清零. The main content area is titled 'PDU Network Configuration' and includes the following settings:

IP 类型	静态
子网掩码	255.255.255.0
IP 地址	192.168.2.109
网关地址	192.168.2.1
DNS	114.114.114.114



The screenshot shows the 'PDU Web System' interface with the '设置' (Settings) tab selected. The browser address bar shows the URL: 192.168.1.192/pdu\_web/chsingle/index.html?time=1760319997843#/set/deployment. The left sidebar contains menu items: 账户管理, 分组管理, 密码修改, 设备部署 (highlighted), and 全局设置. The main content area is titled 'Master mode: Number of cascaded slaves' and 'Slave mode: Slave address'. It includes the following settings:

模式:  主机模式  从机模式

设备地址: 1 [保存]

# Intelligent 2nd-Gen PDU – Dynamic Environment Integration

04



## ❖ Connecting to dynamic environment interface and protocol ❖

### ● TCP/IP Network access mode

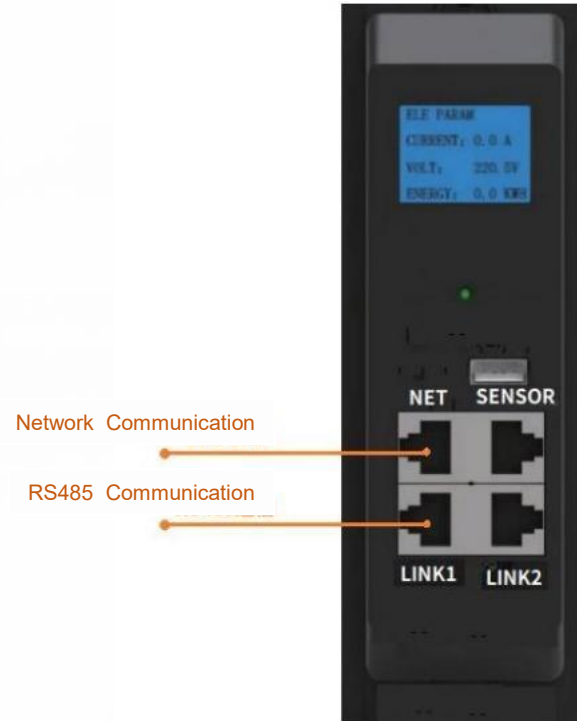
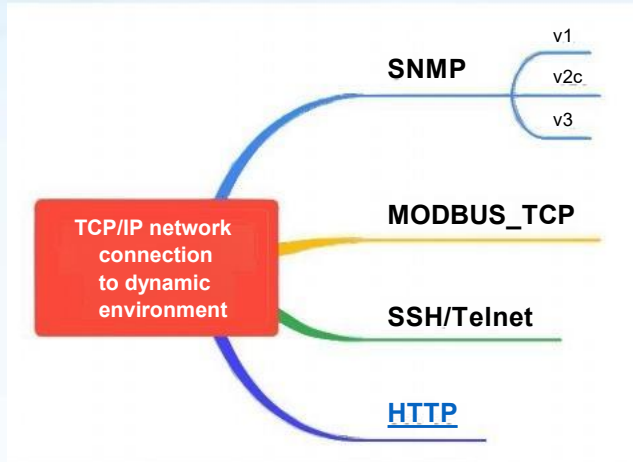

### ● RS485 Communication

- MODBUS\_RTU

## ❖ RS485 Connection to Dynamic Environment ❖

### ● RS485 Connection to Dynamic Environment

- Serial server (dynamic environment host) as RS485 master
- PDU as RS485 slave
- Max 9 PDU slaves per RS485 bus
- Slaves set to slave mode; address 1–9 (unique)



## Example of RS485 Connection to Dynamic Environment

### ● RS485 Connection to Dynamic Environment

- RJ45 RS485 pinout: PIN1/PIN2
- Serial parameters: 115200BPS / 8 / N / 1
- Default baud rate: 115200 (configurable)



- Protocol document: 2nd\_SmartPDU\_ModBus\_vxx.pdf



PIN	Description
1. Orange-White	B545-A
2. Orange	B548-B
3. GREEN-White	
4. Blue	BS45-A
5. Blue-White	RS45-B
6. Green	
7. Brown-White	
8. Brown	GND

## TCP/IP Connection to Dynamic Environment

### ● TCP/IP Connection to Dynamic Environment

#### ➤ Non-Cascaded Mode

- Each PDU uses an independent IP
- Dynamic host communicates with each PDU via TCP/IP

(SNMP/MODBUS-TCP)

#### ➤ Cascaded Mode

- 1 master + N slaves; share one IP
- Dynamic host communicates only with the master (SNMP/MODBUS-

TCP)

Network Server

SNMP  
MODBUS TCP



Slave mode:  
Address 1

Network Server

SNMP  
MODBUS TCP



Master mode  
Number of  
cascaded  
slaves:9

Slave mode:  
Address 1

Slave mode:  
Address 2

Slave mode:  
Address3

Slave mode:  
Address4

Slave mode:  
Address5

Slave mode:  
Address6

Slave mode:  
Address7

Slave mode:  
Address8

Slave mode:  
Address9

### ❖ MODBUS-TCP Integration ❖

- **TCP/IP network interface connected to dynamic environment**
  - PDU: TCP server, port 502
  - Dynamic environment system: TCP client
  - Protocol document: 2nd\_SmartPDU\_ModBus\_vxx.pdf

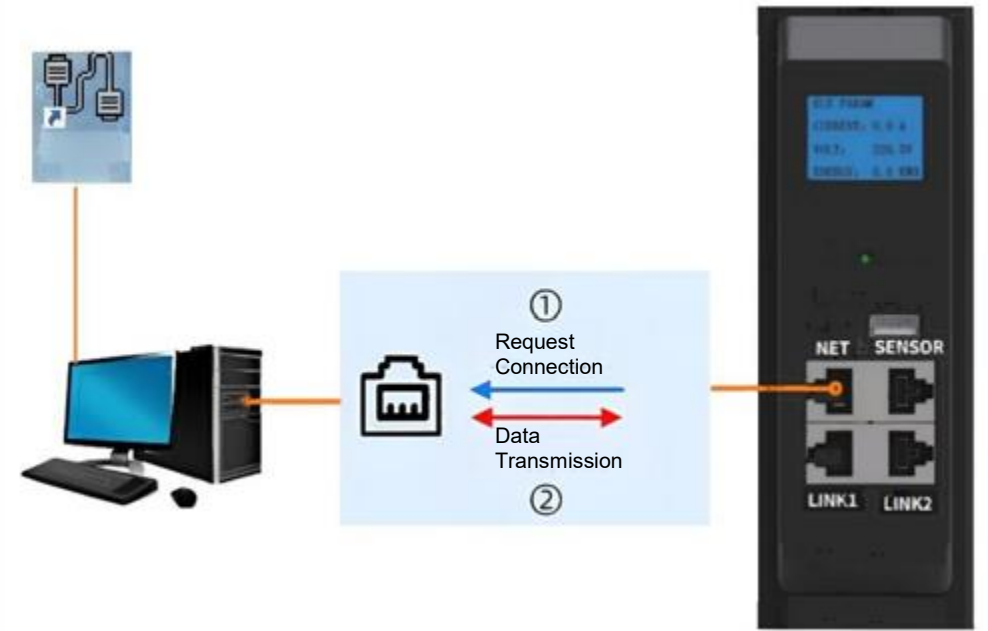

## ❖ SNMP Integration ❖

### ● PDU SNMP Overview

- Simple Network Management Protocol based on TCP/IP; UDP ports 161/162
- Dynamic host: NMS; PDU: Agent
- Versions: v1, v2c, v3
- Documents:
  - 2nd\_PDU\_VXX.MIB
  - Intelligent 2nd-Gen PDU SNMP OID Manual

V1.4.pdf

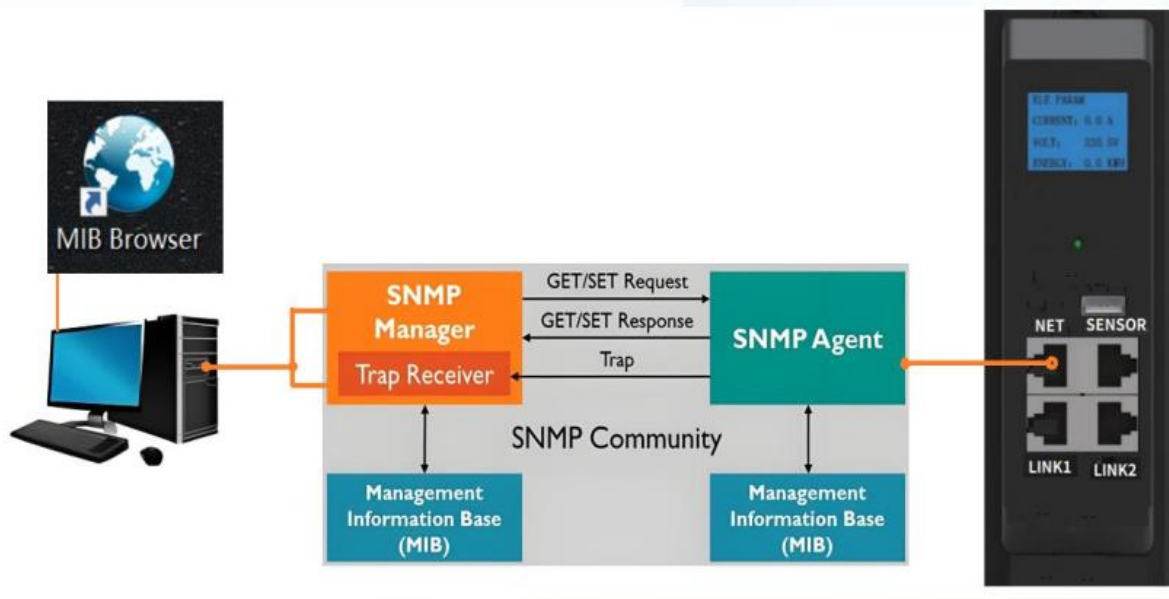

## ❖ SNMP Configuration ❖

## ● PDU SNMP Settings

- Select version: v1/v2c/v3
- Set SNMP Trap receiver IP
- v2c: community strings (public/private)
- v3: user account, authentication (MD5), encryption (AES-256)

账户管理

分组管理

密码修改

设备部署

全局设置

阈值设置

电能清零

邮件管理

级联设置 网络设置 SNMP设置 TELNET/SSH设置 无线网络设置 HTTPS设置 LCD设置 传感器设置 DO声光告警关联

登录超时设置 数据日志设置 空开设置 syslog设置

SNMP 使能 开启

Get 共同体 public

Set 共同体 private

v2c get/set  
Community Setup

SNMP TRAP IP1 192.168.1.12

SNMP TRAP IP2 192.168.1.13

Trap Receiving Address

SNMP 版本 3

USM 账户名 snmp\_user1

安全等级 认证,加密

V3 related settings

认证算法 MD5

认证密码 .....

加密算法 AES-256

加密密码 .....

# Other Communication Protocols

---

05



## ❖ SSH/Telnet Protocol ❖

### ● PDU SSH Configuration

- Username: admin
- Password: pdu123456
- Port: 22

### ● PDU Telnet Configuration

- Username: admin
- Password: pdu123456
- Port: 22

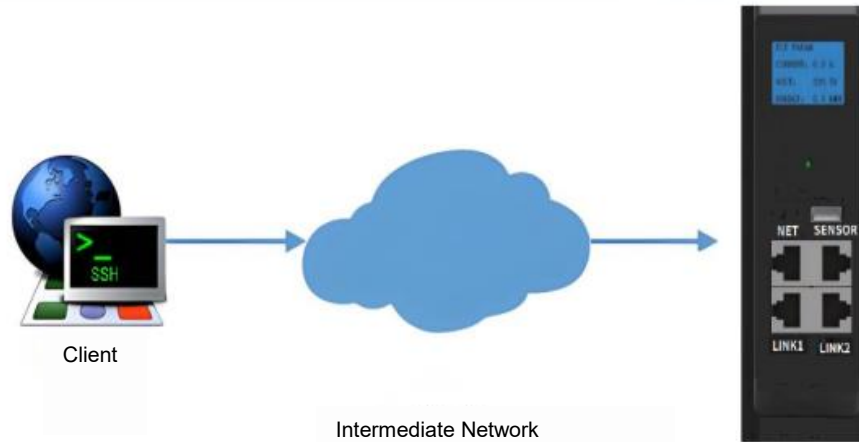

```
✓ 192.168.2.109_telnet_root x
pdu login:
pdu login: root
Password:

BusyBox v1.22.1 (2018-06-13 23:27:07 PDT) built-in shell (ash)
Enter 'help' for a list of built-in commands.

~ # query version
version: v1.6.1
~ #
~ #
```

## ❖ NTP Time Synchronization ❖

### ● PDU NTP Settings

- Configure NTP server, port, synchronization period
- Time zone: UTC+8  
(Beijing/Chongqing/Singapore)
- Mode: NTP / manual

系统时间设置 设备重命名 恢复出厂设置 配置导出 配置导入 在线升级 黑白名单设置 声音清除 设备重启 报警屏蔽

延时上电 一键同步阈值 支路电压报警屏蔽

时区 (UTC+8)北京和重庆和新加坡

更新方式  NTP  手动

服务器 192.168.1.123

端口 123

周期(分钟) 5

Select NTP time synchronization mode

NTP Service Configuration

## ❖ SMTP/SMTPS Protocol ❖

### ● SMTP/SMTPS Protocol

- Standard email transmission protocol
- PDU sends alarm messages to data center administrators via email

### ● PDU SMTP/SMTPS Configuration items

- server address,
- sender/recipient,
- password/auth code,
- port

The screenshot shows the 'PDU Web System' interface. The top navigation bar includes '主页', '传感器', '支路', '设置', and '日志'. A login timeout notice '登录超时:2时17分11秒' is visible. The left sidebar contains menu items: '账户管理', '分组管理', '密码修改', '设备部署', '全局设置', '阈值设置', '电能清零', and '邮件管理'. The main content area is titled '邮件信息' and '邮件设置'. The configuration form includes the following fields:

邮件服务器	smtp.qq.com
接收邮箱	1025054559@qq.com
发件邮件	1025054559@qq.com
密码	.....
使能	开启
端口	25 (SMTP)

A '保存' (Save) button is located at the bottom right of the form.



**THANKS**

**Website:** [www.wxbom.cn](http://www.wxbom.cn)

Sincerity • Cooperation

Win-Win • Future

**Address:** Building A3, Tian'an Smart City, No.228 Linghu Avenue, Xinwu District, Wuxi