

Company Presentation

Since 2012



Ver. 2025-04

C O N T E N T S

PART.1

Who is AOK

PART.2

Why is AOK

PART.3

Supply Chain
& QC Control

PART.4

Solutions &
Products

A night scene of a modern building with palm trees and a street lamp. The building has a dark facade with vertical slats. A tall street lamp with a solar panel on top is illuminated, casting a bright glow. The sky is dark blue. The foreground is a paved area with some greenery.

WHO IS AOK

Layout Globally to Serve Clients



Help Customers
for Our Top Mission

20000m²+
Production Base

Sophisticated
R&D Team

International
Utility Patents

Professional QC
Testing & Lab

Globally
Certificated

Oversea
Warehouses

International
Strategic Partners



40+

R&D engineer team

200+

Patent certificates

50%+

Energy consumption reduction

100+

Countries clients served

20,000+

Projects successfully installed

PORTFOLIO

- Established in **2012**
- Factory scale: **15,000m²+** factory/**5,000m²+** office space
- Average capacity: **2000-3000**pcs/day
- Comprehensive R&D team, **80+** annual products design, tailored optics design & lighting simulation service
- Outdoor/indoor lighting **OEM/ODM/SKD/CKD** & expectational customer service

TECHNOLOGY

- High efficacy: Superior energy efficiency with cutting-edge technology
- Advance: Refined die-casting and manufacturing techniques
- Smart lighting: IoT intelligent lighting solutions, solar powered systems design
- Eco-friendly: Recycled materials and components for products & packaging

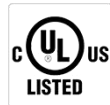
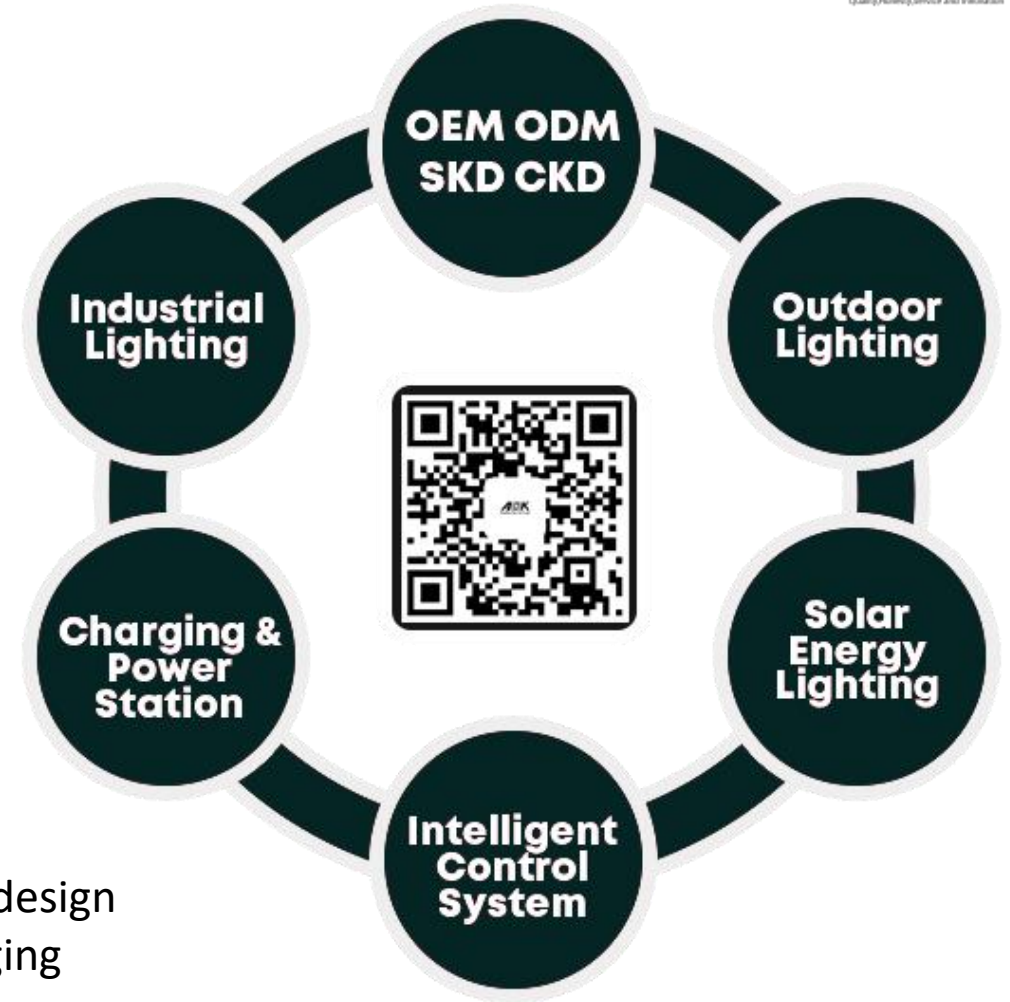

IP66
IK10

LM79
TM21

ISO:9001
ISO:14001

ISO:45001

Development History of AOK



2012



Established factory with ISO9001 & ISO14001 standard

2013



AOK became the **Best Partner with Lumileds**. We hold annual technical seminar ever since

2014



Certified by **UL** company with factory audit and passed **TUV** factory inspection

2015



Won the prize of **Innovating Enterprise** China

2018



Established **Die-casting Factory**

2017 DIALux



Set up company and **Technical Service Center in USA**, branch in Germany & France, and partnership with **DIALux**

2016



Become a **member of Australia Lighting Council**, factory expanded to 8,000 square meters

2022



Certified by **ISO45001** standard and **BSCI**



2023



Established **AOK Huizhou** 2023

2024



Established **Philippine Factory**

2026

Looking forward to cooperate with you

Milestone



130lm/W

- In 2012, our LED streetlight series led in luminous efficiency, reaching 130lm/W, while other products were limited to 100lm/W.

LUMILEDS

- LUMILEDS showcased AOK products as demonstration fixtures in the lightfair.

30,000 Units

- For a 30,000 units streetlight project, AOK 135W solution, optimized for light distribution, outperformed a competitor's 150W product, helping the client win the project.

U.S. Official

- One of the first Chinese companies recognized by U.S. official highway projects, aiding clients in winning contracts.

Invention Patents

- We've developed tool-less maintenance street lights and floodlights with invention patents, offering eco-friendly, cost-effective, and recyclable solutions.

210lm/W~220lm/W

- New high-efficiency lighting system with a luminous efficacy of 210lm/W.

Scenario-based Applications

- R&D of professional scene application solutions for airports, stadiums, ports, solar systems, lighting towers, and other similar applications.





Our Vision

Global innovation with trustworthy lighting solutions.

Our Mission

Efficient illumination powering a sustainable future.

Our Core Values

QUALITY



HONESTY



SERVICE



INNOVATION



We Are Helping



People

to boost their productivity by providing high-quality lighting with safety and comfort, minimal glare to keep operations smooth.



Venues

good lighting is built to withstand tough environments, while also providing powerful light, ensuring the ideal light solution for the spaces & venues.



Environments

we design efficient, low-energy solutions with minimal maintenance for cost savings and optimal lighting harmony.



WHY IS
AOK

MARKET ACCESS

- Robust sales, service & R&D team in key markets (USA, Europe, Asia, Mid-east, etc.)
- Transnational agent cooperation channels served
- Technical support for local manufacturing

QC & CUSTOMER SERVICE



Quality assured, with customer complaints **<0.1%**



21 major testing facilities, quality guaranteed



28+ rigorous quality inspection procedures



After-sales response within **24 hrs**, resolution in **48 hrs.**

MARKET SHARE

U.S.A.: 35%

Europe: 20%

Mid-east: 15%

Aisa: 15%

South America: 15%

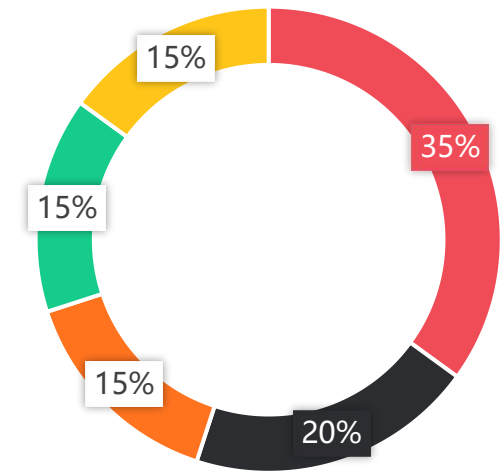

■ U.S.A. ■ Europe ■ Mid-east ■ Aisa ■ South America

6 Key Advantages to Support Your Business



Project Protection

Private mode, agreements & approvals



Triangle Customer Service

Consultan-style service, sales, operation & tech team support



R&D & Design Service

Over 80 new product designs per year with patent protection.



Project Simulation Service

Optical design, project simulation, and optimization.



Delivery Assurance

Excellent supply chain integration management to ensure timely delivery.



Financial Support

Reasonable payment term planning to ensure smooth project execution.

Systematic Production & Security Management

MAS

Manufacturing automation system

SCSMS

Security management system for the supply chain certificate

PLM System

Product lifecycle management

 **BSCI**

Business social compliance initiative

ISO:28000

Transportation and logistics risk control

Sophisticated R&D Team



Annual New Products Design

80+

- OEM & ODM
- Complete Design in 1~7 Days
- Lighting Design for Clients

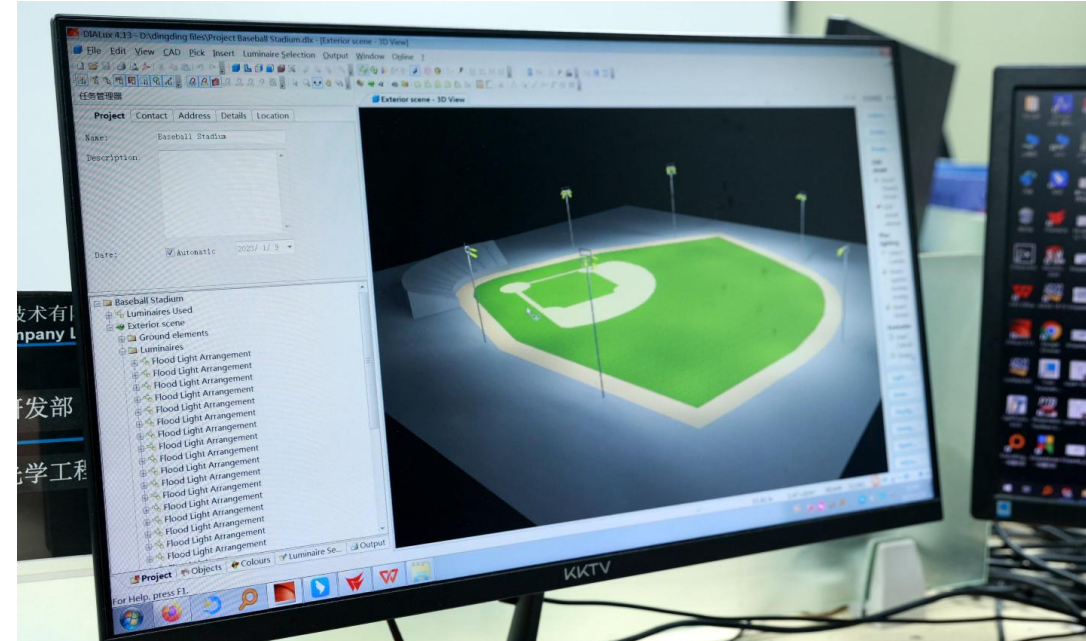
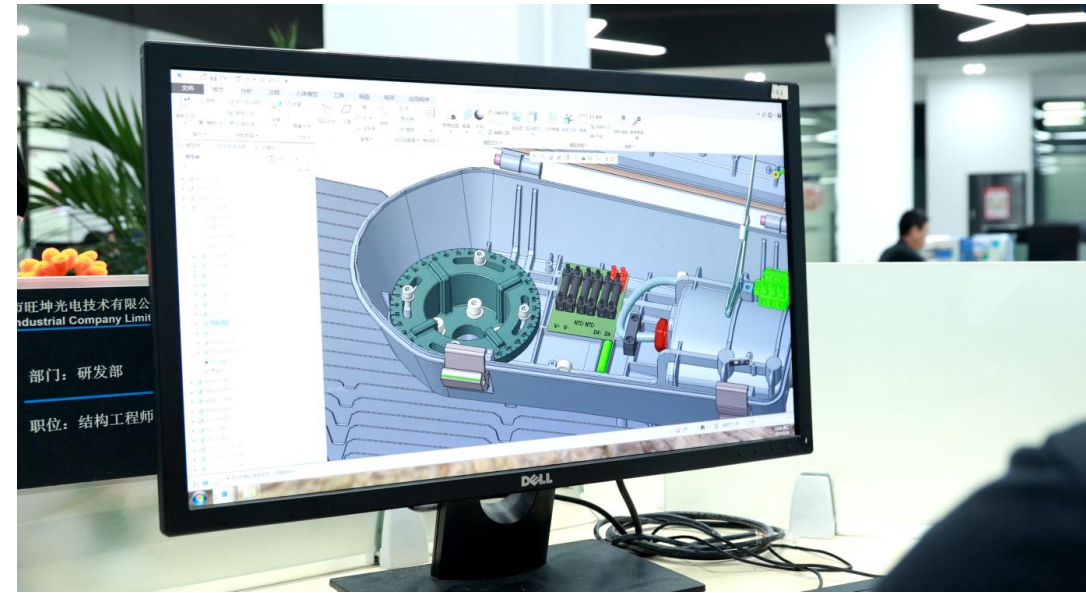

Sophisticated Solutions for **Tailor Made Project**

1 For Better Fitting

2 For Better Lighting

3 For Better Performance



Product Appearance
Design



Structural Component
Design



Optical Module
Design



Electrical Circuit
Design



Project Simulation
Design

Customized R&D Procedure

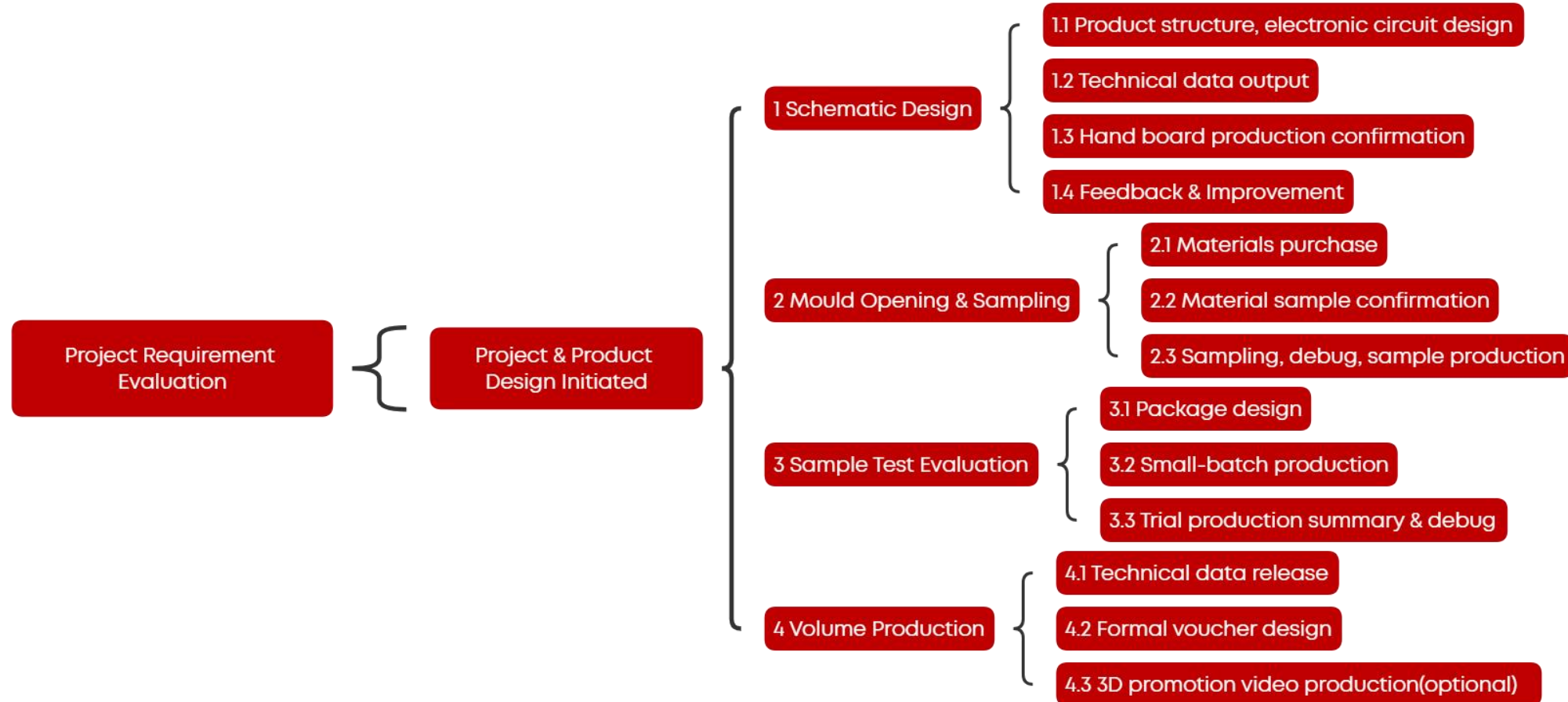

With over a decade of experience in structural, thermal, mechanical, and optical design, our R&D team can meet unique project requirements and performance expectations.

We're dedicated to improving our product development for reliable lighting solutions.

200+ Utility Patents



The AOK R&D team consistently generates fresh concepts and fine-tunes our tailored solutions.

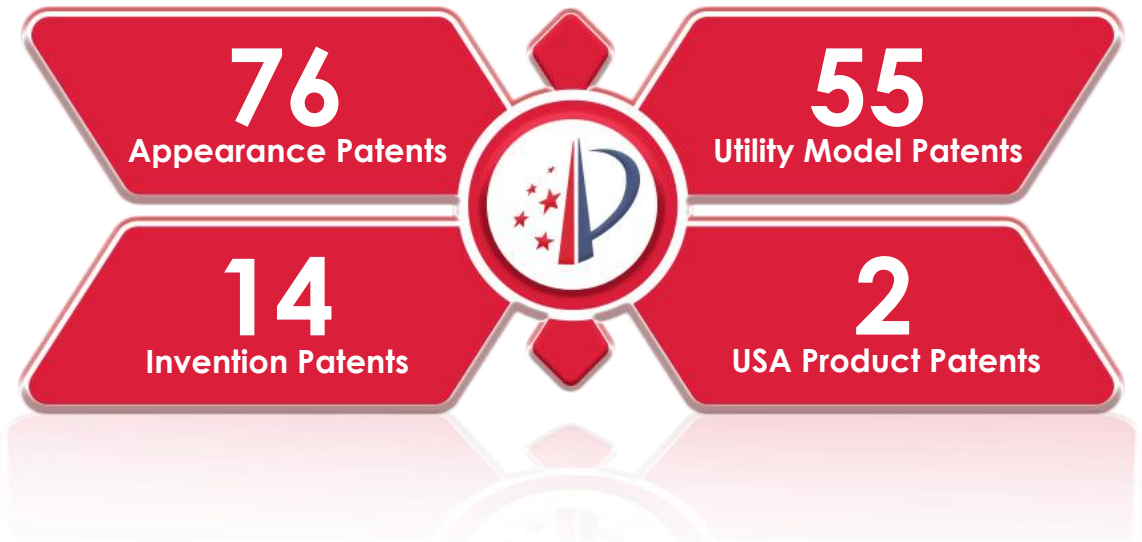
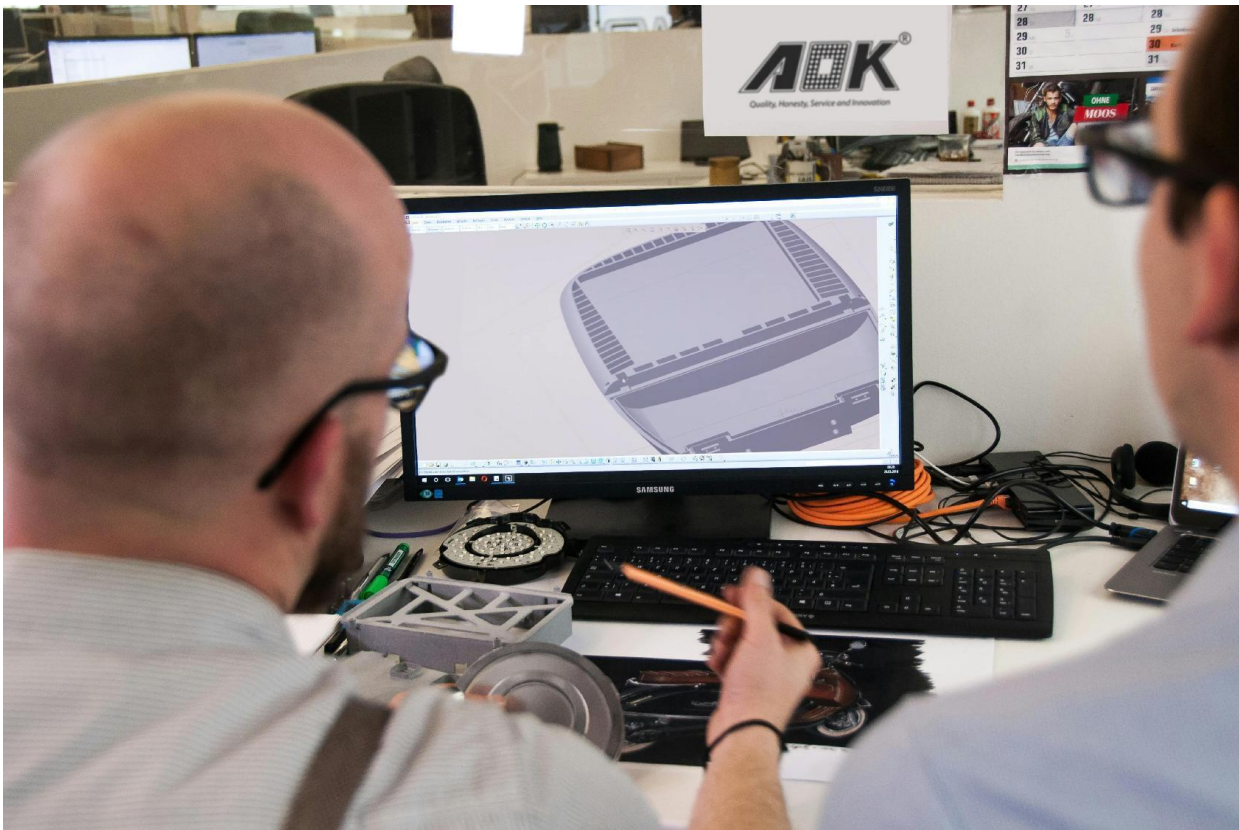

*Old Products Not Included

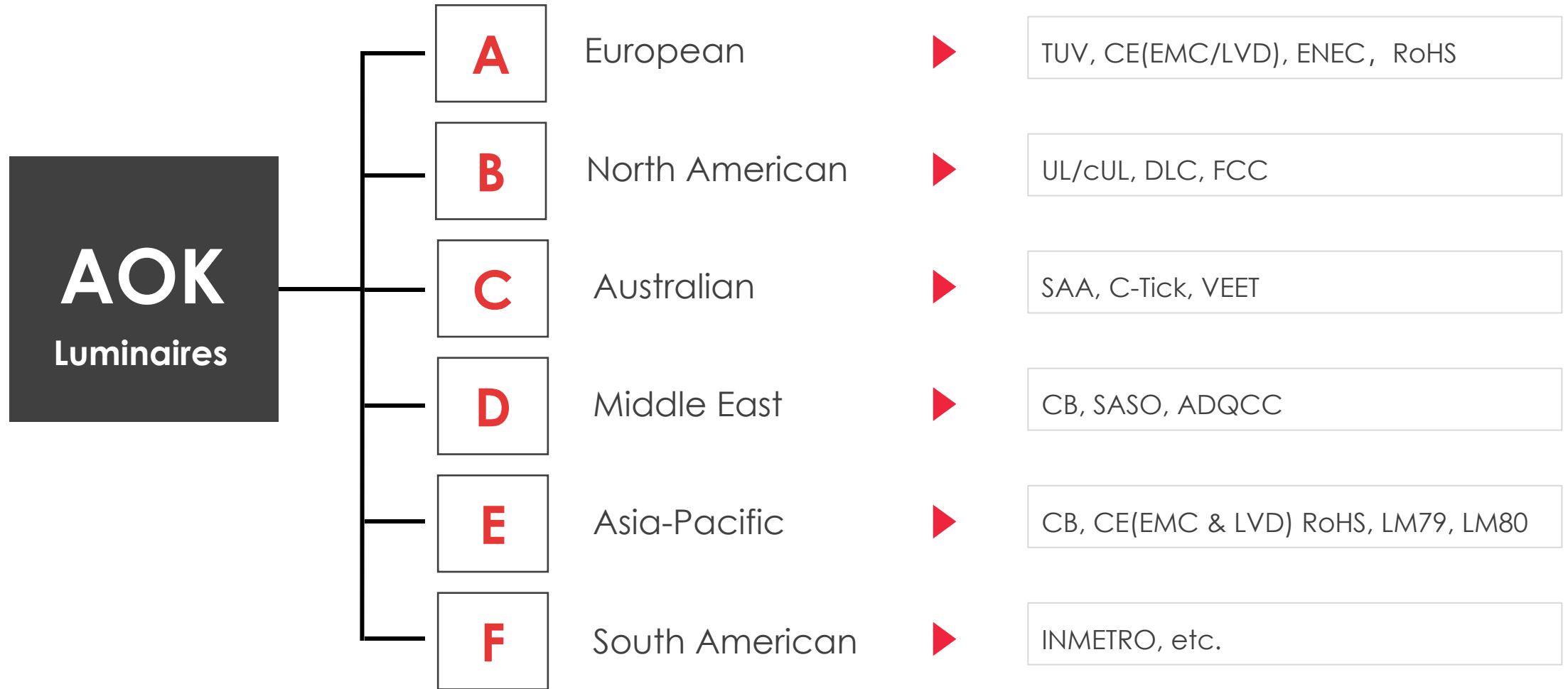

National Honor & Prize



Other Honor Prizes & Certificates





Supply Chain & QC Control



OSRAM



CREE ⇄™

PHILIPS

INVENTRONICS



MOSO®



WAGO



iLightsln

Selection of Internationally Renowned Brands:

- We have established long-term, stable partnerships with multiple reputable suppliers to ensure the quality of raw materials, components, and a dependable supply.



Die-Casting

We operate die-casting machines from 280T to 2000T, allowing us to meet the requirements for various structural castings.



Rapid Response

Our supply chain, based in the Pearl River Delta, allows for rapid response and flexible production adjustments to meet market demand. Efficient order processing, quick manufacturing, and timely supplier deliveries boost factory responsiveness and market competitiveness.



Payment Credit

We work closely with suppliers to ensure reasonable payment terms and financial planning, and develop schedules based on project timelines, allowing us to better support bulk delivery deadlines.

Professional QC Testing & Lab-28+ Procedures

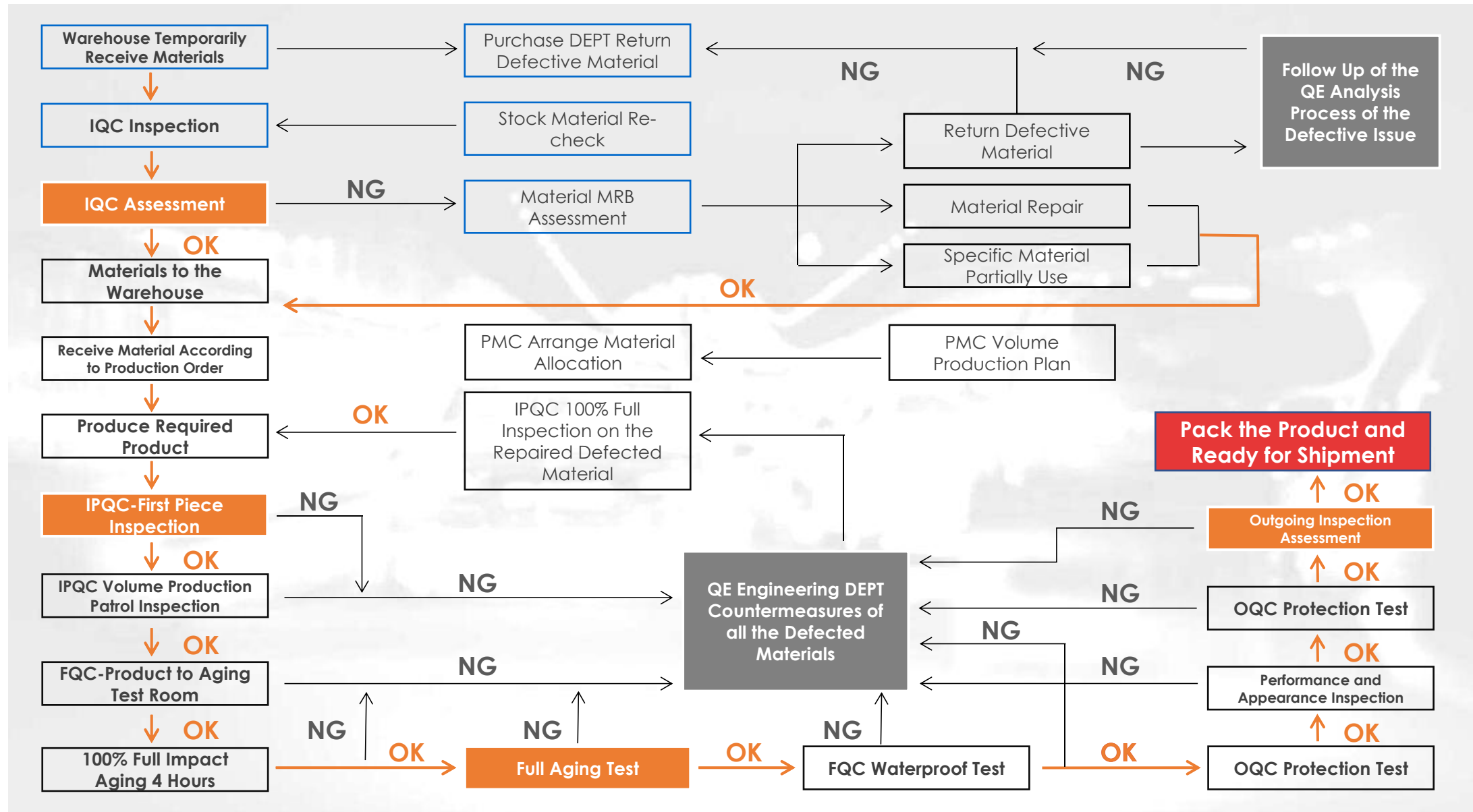

Professional QC Testing & Lab-Testing Facilities



IES Test



IK Impact Test



Package Drop Test



Multifunctional Tester



Power Supply Test



Battery Testing System

Professional QC Testing & Lab-Testing Facilities



High Temperature & Humidity Test



Integrating Sphere Test



Color Difference Meter

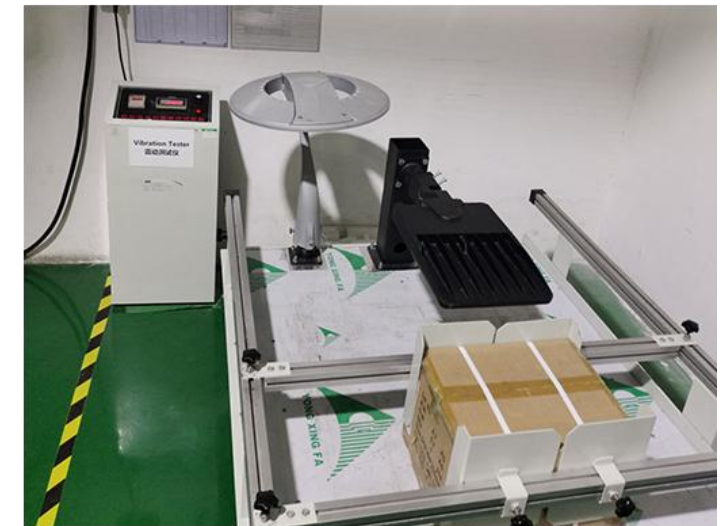

Vibration Test



Laser Machine



Automatic Packaging Machine



Salty & Fog Test

Waterproof test



Rainfall Test

Professional QC Testing & Lab-Testing Facilities

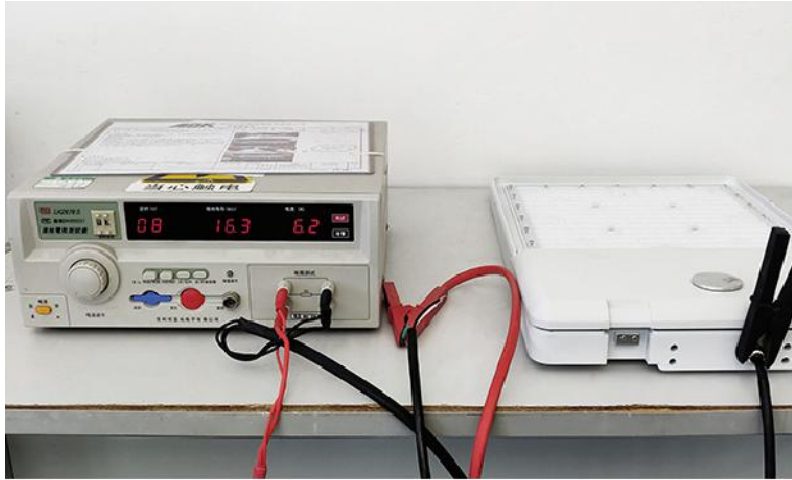

Ground Resistance Test



Internal Resistance Test



Powder Adhesion Test



Insulation Test



Power Withstand Voltage Test



Coating Thickness Gauge



Luminaire Sealing Integrity Tester



Moments of AOK

Feature at A Glance



Office & Factory Building



Product Assembly Line



Production Line



Automatic Packing Line



SMT



QC Control

Feature at A Glance



Company Showroom



Shenzhen Office



Shenzhen Office



Fuzhou Office



USA Technical Service Center

Team Buildings





2025-LFI USA



2025-Poland

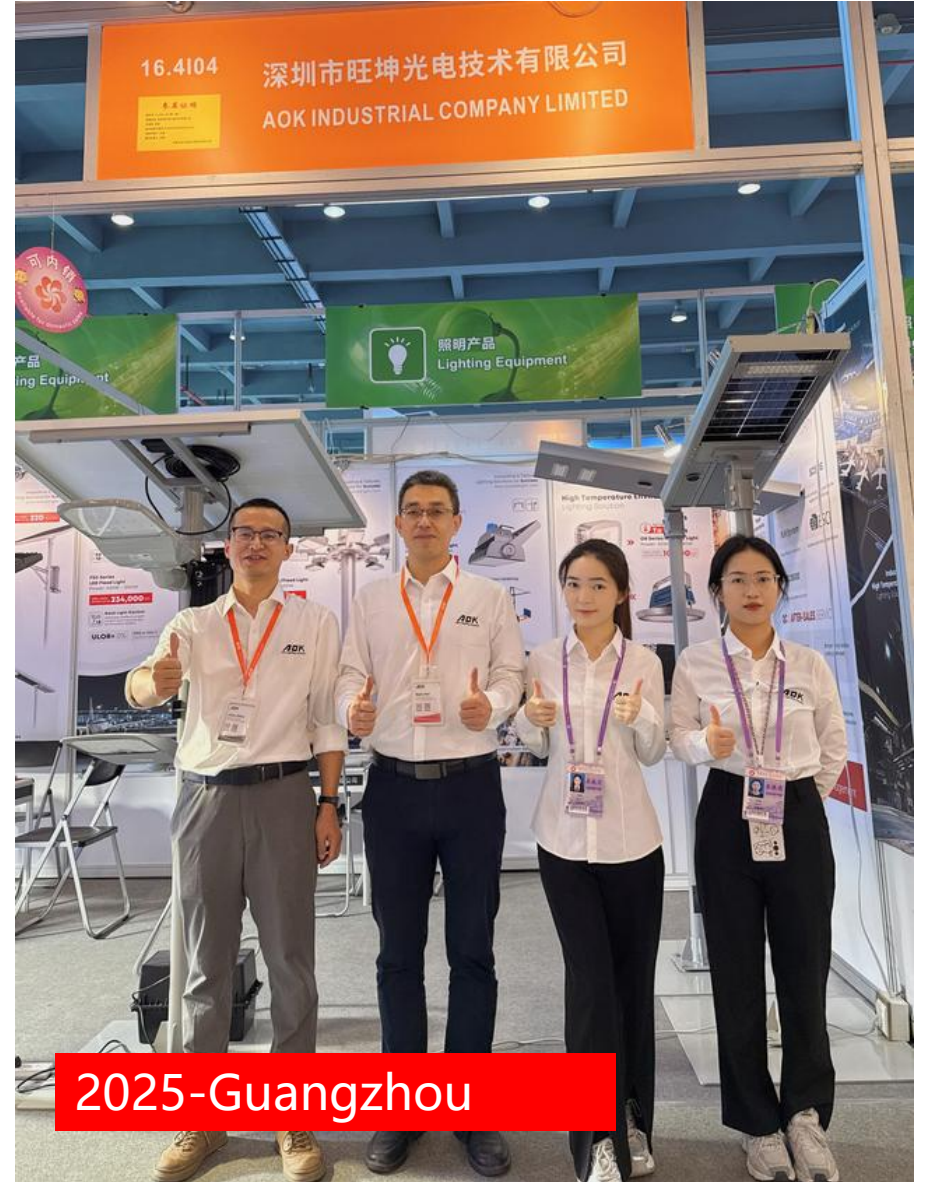

2025-Guangzhou



2025-Japan

AOK @ Lighting Expo



2024-Guangzhou



2024-Hong Kong



2024-Brazil

AOK @ Lighting Expo



2023-Guangzhou

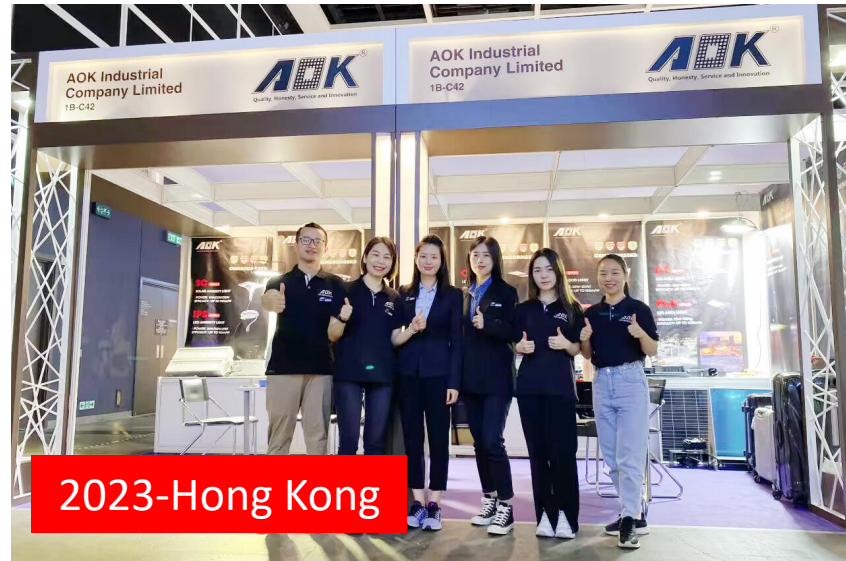

2023-Hong Kong



2023-LFI USA



2023-Dubai



2022-Germany



2019-LFI USA



Solutions & Products

Lighting Solutions Based on Applications



Coastal Lighting Solution



Road & Street Lighting and Smart Control Solution



Sports Lighting System and Smart Control Solution



Solar Power Lighting Solution



Airport Lighting Solution



Seaport Lighting Solution

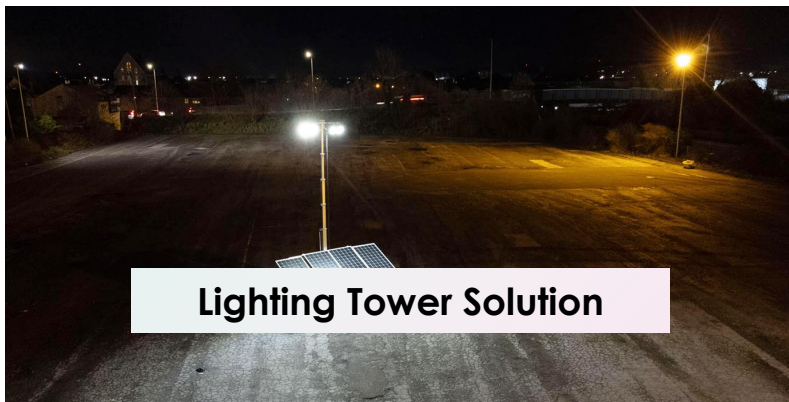

Lighting Tower Solution



Crane Lighting Solution



Industrial High Temperature Lighting Solution

Sports & Flood Lighting

LED Stadium Light LED Flood Light

POWER: 400W-1800W
Up to **150**lm/W

**DMX or DALI 2
Control Options**

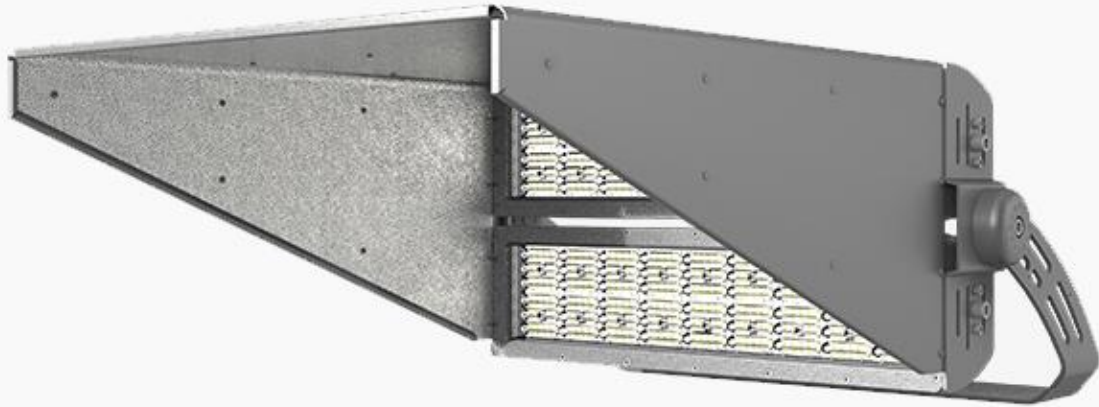

ISF Series

LED Flood Light LED Stadium Light

POWER: 315W-720W
Up to **170**lm/W



INS Series

LED Flood Light Highmast Light

POWER: 400W-960W
Up to **170**lm/W



OF Series

LED Stadium Light LED Flood Light

POWER: 400W/500W/600W/630W
Up to **180**lm/W



FSA Series

LED Area Light LED Tennis Light

POWER: 230W-420W
Up to **172**lm/W



OT Series



Sports & Flood Lighting

LED Sports Light
LED Flood Light

POWER: 400W-1200W
Up to **200**lm/W

CASAMBI optional



FSC Series

LED Sports Light
LED Flood Light
POWER: 600W-1800W
Up to **160**lm/W



FSD Series

LED Sports Light
LED Flood Light
POWER: 300W-2000W
Up to **150**lm/W



INF-SG Series

LED Highmast Light
LED Flood Light
POWER: 400W-600W
Up to **140**lm/W



HMA-B Series

Sports & Flood Lighting

LED Flood Light Toolless Maintain

Power: 20W-500W
Up to **200** lm/W

Multiple Installation Options



FLC Series



LED Flood Light

POWER: 50W-300W
Up to **150** lm/W



FLB Series

LED Flood Light

Power: 150W-600W
Up to **180** lm/W



FLD Series

Street Lighting Solution

LED Street Light
Tool-less maintain

POWER: 20W-120W
Up to **165**lm/W



ILE Series

LED Street Light
Smart control ready
Power: 20W-300W
Up to **190**lm/W



ILA Series

LED Street Light
Multiple options
POWER: 20W-300W
Up to **200**lm/W



IL02 Series

LED Street Light
POWER: 20W-230W
Up to **145**lm/W



IL03 Series

LED Street Light
POWER: 10W-50W
Up to **165**lm/W



ILB Series

LED Street Light
POWER: 30W-320W
Up to **150**lm/W



IL06 Series

LED Street Light
POWER: 30W-300W
Up to **160**lm/W



IL08 Series

Street Lighting Solution

LED Street Light

POWER: 30W-150W
Up to **160**lm/W



ILC Series

LED Street Light

POWER: 30W-60W
Up to **160**lm/W



ILD Series

LED Street Light

Power: 20W-230W
Up to **220**lm/W



ILF Series

LED Street Light

Power: 20W-135W
Up to **220**lm/W



ILG Series

LED Street Light

Power: 20W-300W
Up to **185**lm/W



ILH Series

LED Highmast Light
Express way & port

POWER: 230W-720W
Up to **170**lm/W



INM(01/03) Series

LED Highmast Light
LED Flood Light

POWER: 400W-600W
Up to **140**lm/W



HMA-A Series

LED Highmast Light
Express way & port

POWER: 400W-600W
Up to **140**lm/W



HMB Series

Area & Garden Lighting

LED Area Light LED Shoebox Light

POWER: 75W-420W
Up to **172** lm/W



CCT & Power
Adjustable Optional

OT Series

LED Area Light
Shoebox / Parking lot lighting
POWER: 80W-300W
Up to **185** lm/W



OT02 Series

LED Garden Light
LED Amenity Light
POWER: 25W-300W
Up to **135** lm/W



IP/IPS Series

Parkinglot Light
LED Area Light
POWER: 75W-230W
Up to **150** lm/W



PLA Series

LED Area Light
Shoebox / Parking lot lighting
POWER: 100W-300W
Up to **160** lm/W



PLB Series

Solar Lighting Solution

LED All in One Solar Street Light

POWER: 20W-120W
Up to **210**lm/W



SD Series

LED All in One Solar Street Light

POWER: 20W-60W
Up to **210**lm/W



SE Series

LED Solar Garden Light Grid/Solar/Hybrid powered

POWER: 10W-30W
Up to **190**lm/W



SC Series

LED All In one Solar Street Light

Power: 15W
Up to **200**lm/W



SLA Series

Outdoor Lighting Solution

Plug & Play LED Solar Street Light

POWER: 40W-100W
Up to **220** lm/W



SLB Series

LED All in One Solar Street Light

POWER: 20W-30W
Up to **200** lm/W



SLC Series

LED Two In one Solar Street Light

POWER: 40W
Up to **180** lm/W



STA Series

Solar Power Lighting System

Power: 20W-230W
Up to **220** lm/W



- ① Flexible Lighting Fixture Options
- ② Flexible Battery & Solar Panel Installation Options

SL Series

Outdoor Lighting Solution

LED All In one Solar Street Light

Power: 30W/60W
Up to **200**lm/W



SAF Series

LED All In One Solar Street Light

POWER: 20W-300W
Up to **220**lm/W



High Capacity
SAA Series

LED All In one Solar Street Light

POWER: 30W-300W
Up to **200**lm/W



SAB Series

LED All In one Solar Street Light

POWER: 30W-300W
Up to **220**lm/W



SAC Series

LED All In one Solar Street Light

POWER: 20W-300W
Up to **200**lm/W



SAD Series

LED All In one Solar Street Light

POWER: 20W-300W
Up to **200**lm/W



SAE Series

LED Solar Garden Light Landscaping

IP65 rating



SGA Series



Highbay Lighting Solution

LED Highbay Light

POWER: 100W / 150W / 200W
Up to **210** lm/W



HBE Series

LED Highbay Light
Zigbee dimming optional

Power: 60W-240W



OH Series

 **High Temperature Environment**
Lighting Solution



LED Highbay Light

Power: 150W-600W
Up to **180** lm/W



FLD Series

LED Highbay Light
4 Times cable radius

Power: 100W-600W
Up to **210** lm/W

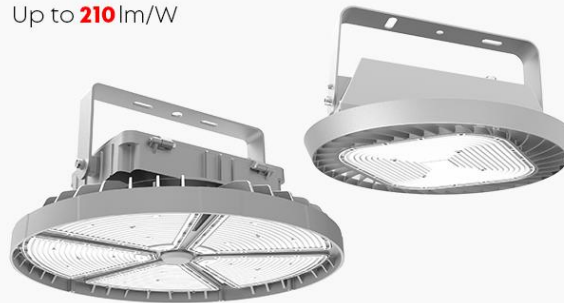

OB02 Series

LED Highbay Light
Modular installation

Power: 75W-145W/150W-290W/225W-435W
Up to **200** lm/W



Toolless maintain

IX Series

More products available

Project Reference

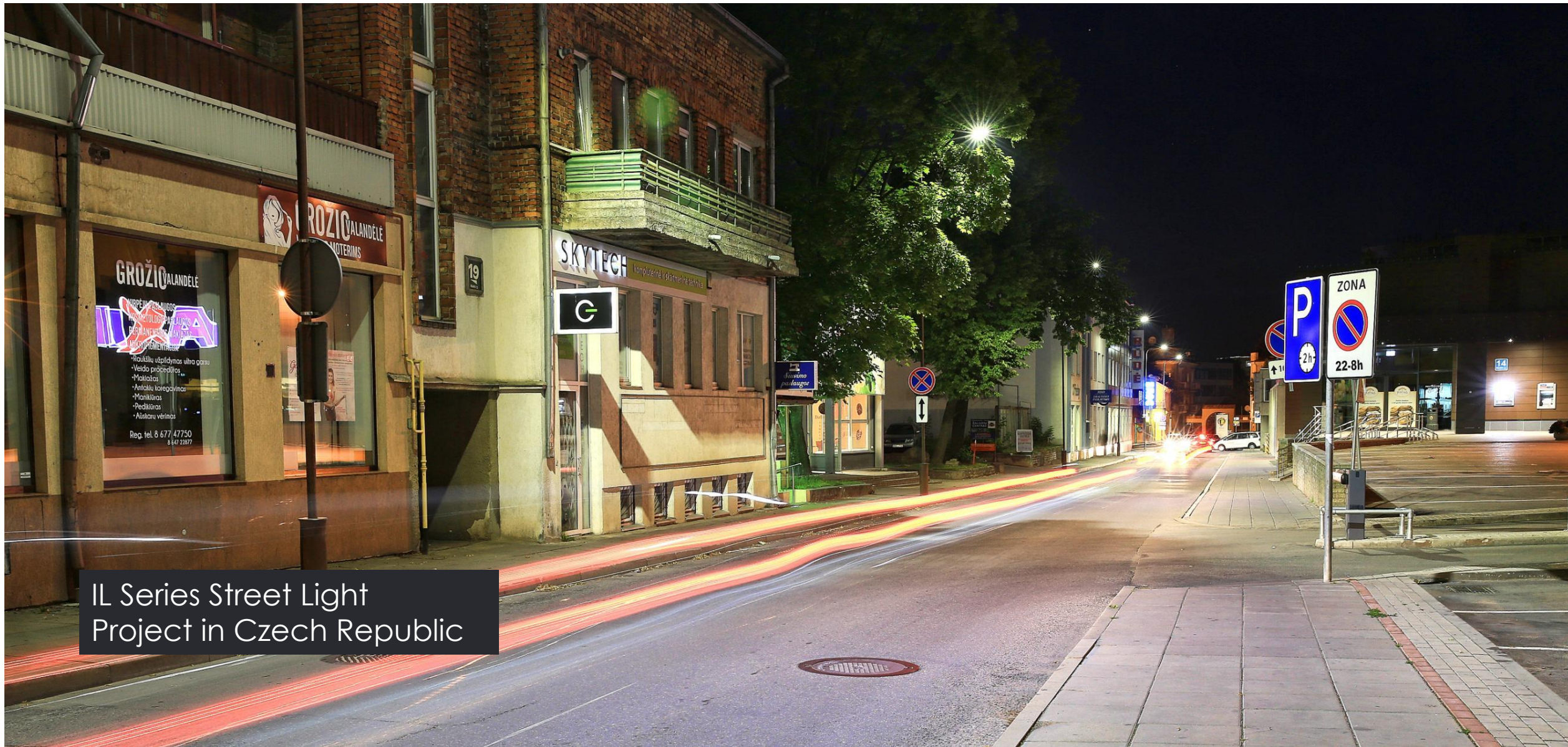

IL Series Street Light
Project in Czech Republic

Project Reference



IL02 Series Street Light-100W
Project in Romania

Project Reference

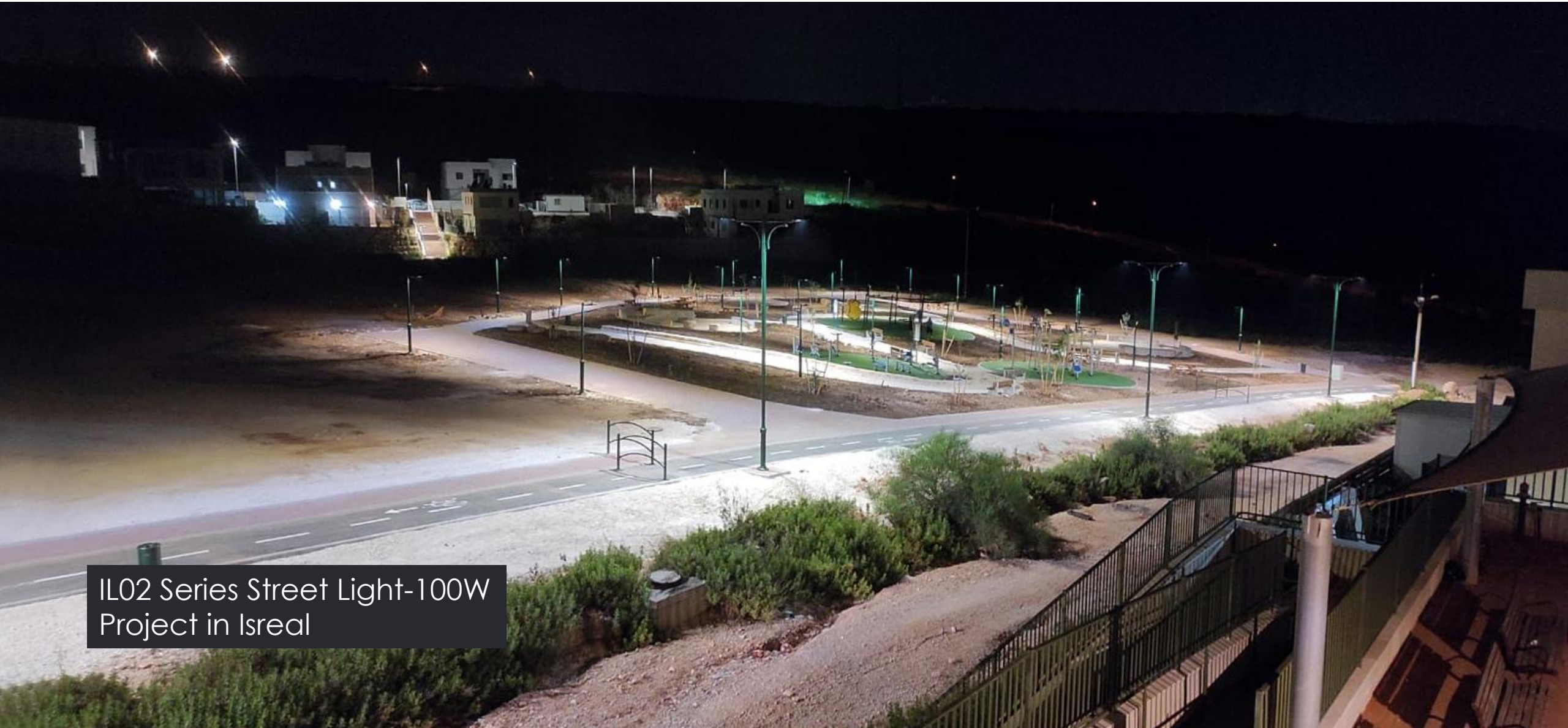

IL02 Series Street Light-100W
Project in Isreal

Project Reference



Project Reference

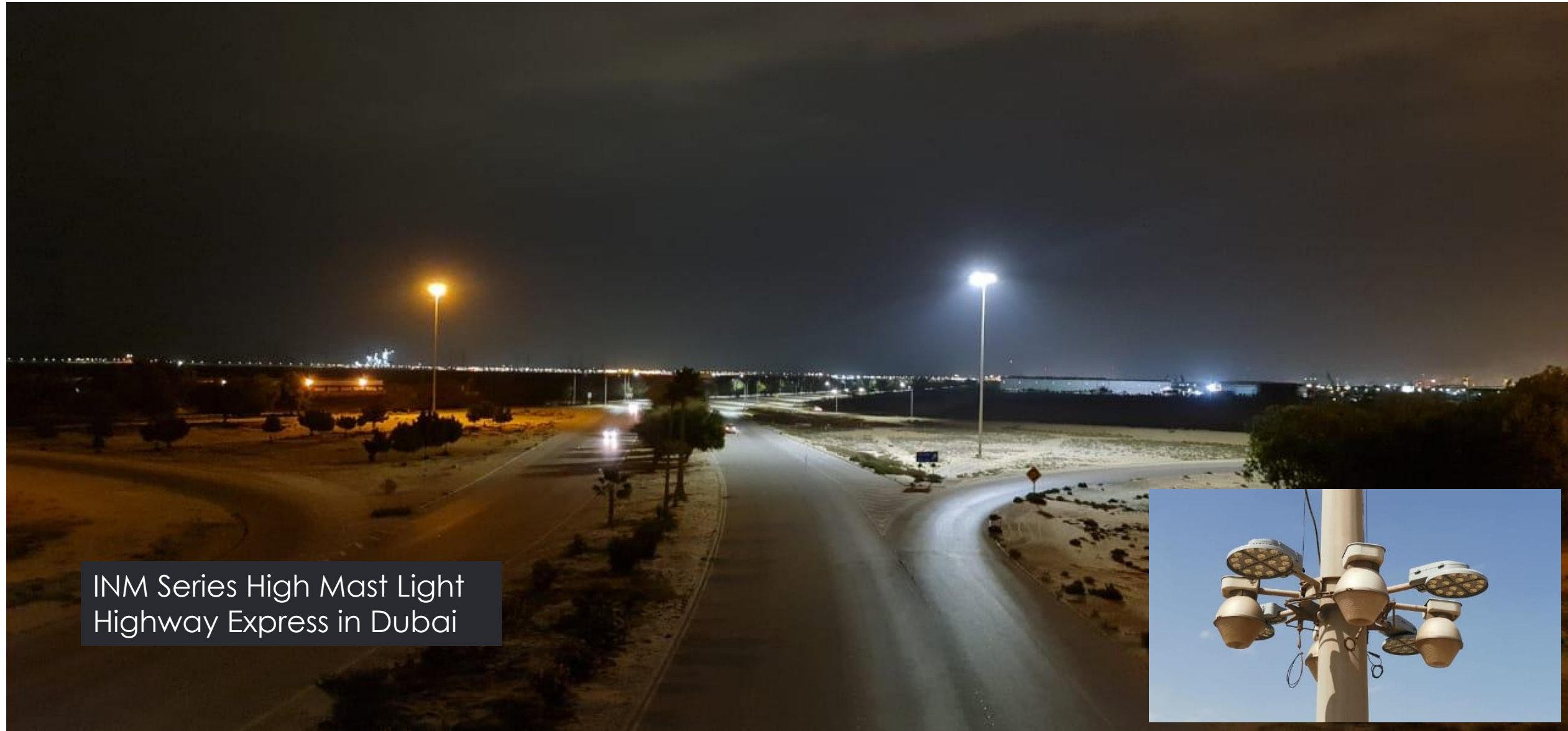

INM Series High Mast Light
Highway Express in Dubai



Project Reference



Project Reference



Solar Street Light-IA and SL Project in Indonesia

29 Dec 2020 09:31:54



Project Reference



SC Series Solar Street Light
Project in USA



Project Reference



Area Light
Parking Lot Project in
U.S.A

Project Reference

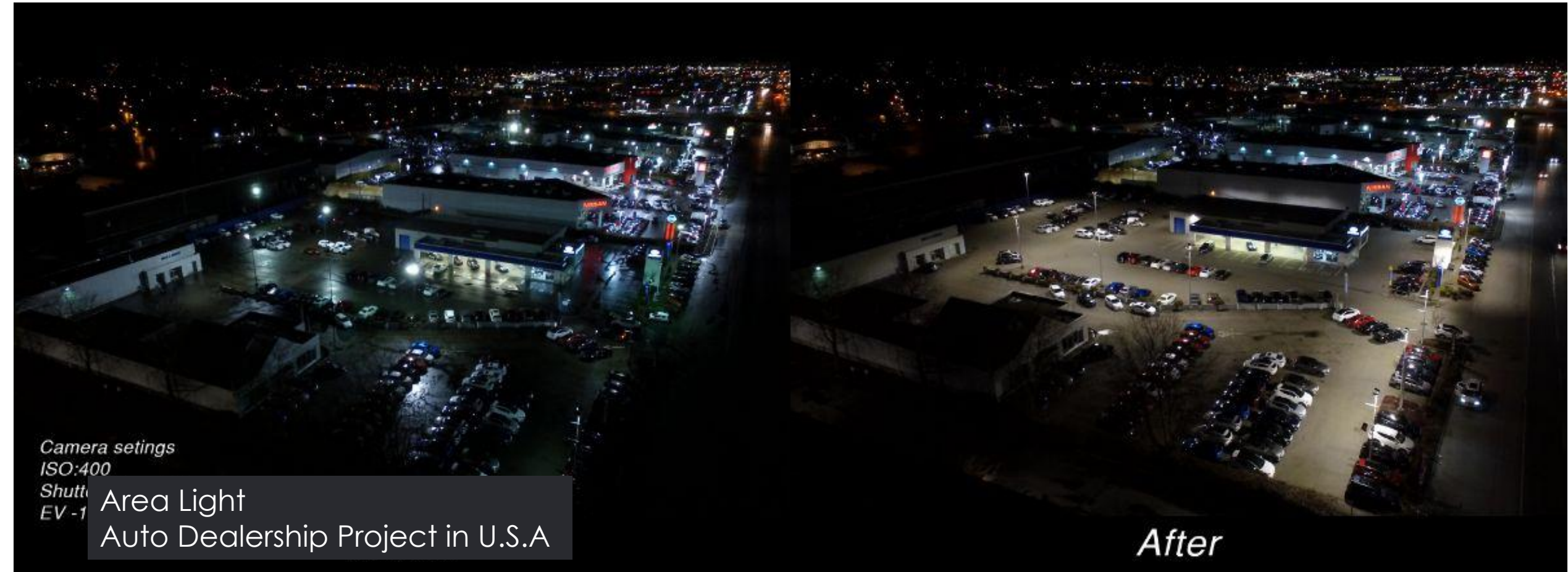

Camera settings
ISO:400
Shutter
EV -1

Area Light
Auto Dealership Project in U.S.A

After

Project Reference



INS Series Stadium Light-720W
Sports Field Remodel, China

Project Reference

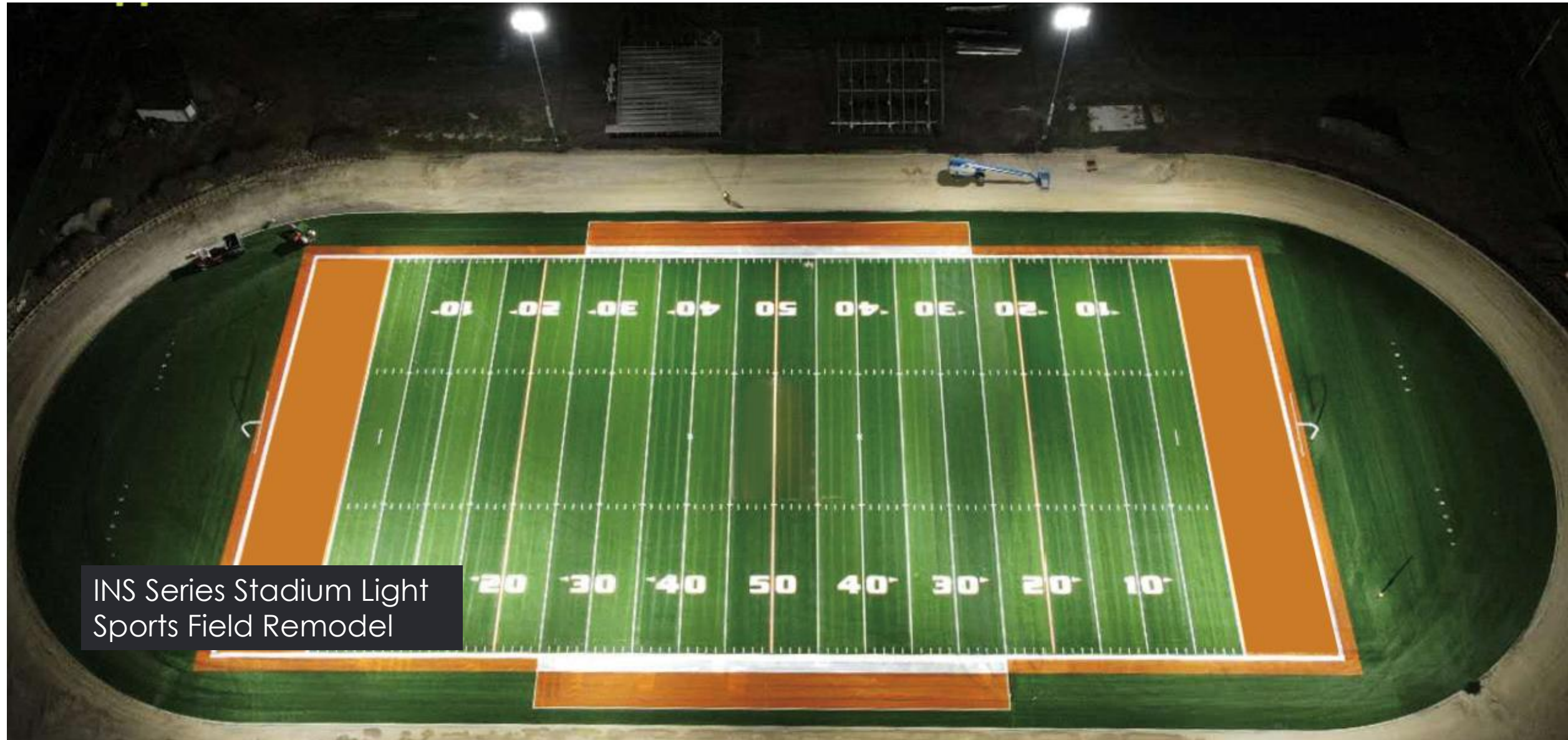

INS Series Stadium Light
Sports Field Remodel

Project Reference

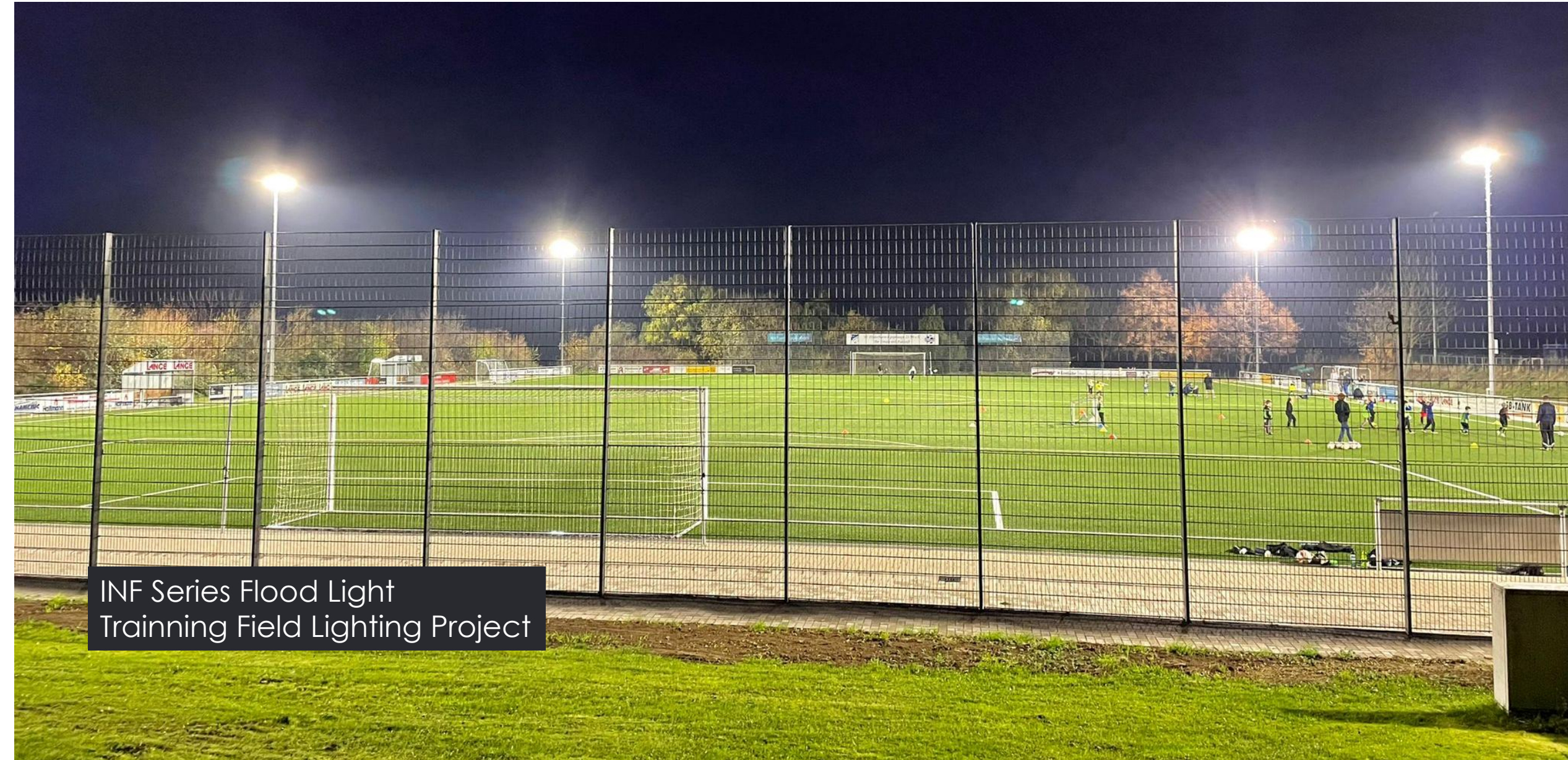

INF Series Flood Light
Training Field Lighting Project

Project Reference

An aerial night photograph of a golf course. The green grass is brightly lit by numerous floodlights, creating a vibrant green glow. The course features several sand traps, a winding path, and is surrounded by dense evergreen trees. The sky is dark, and the overall scene is illuminated by the artificial lights.

FSC Series Flood Light
Golf Field Lighting Project

Project Reference

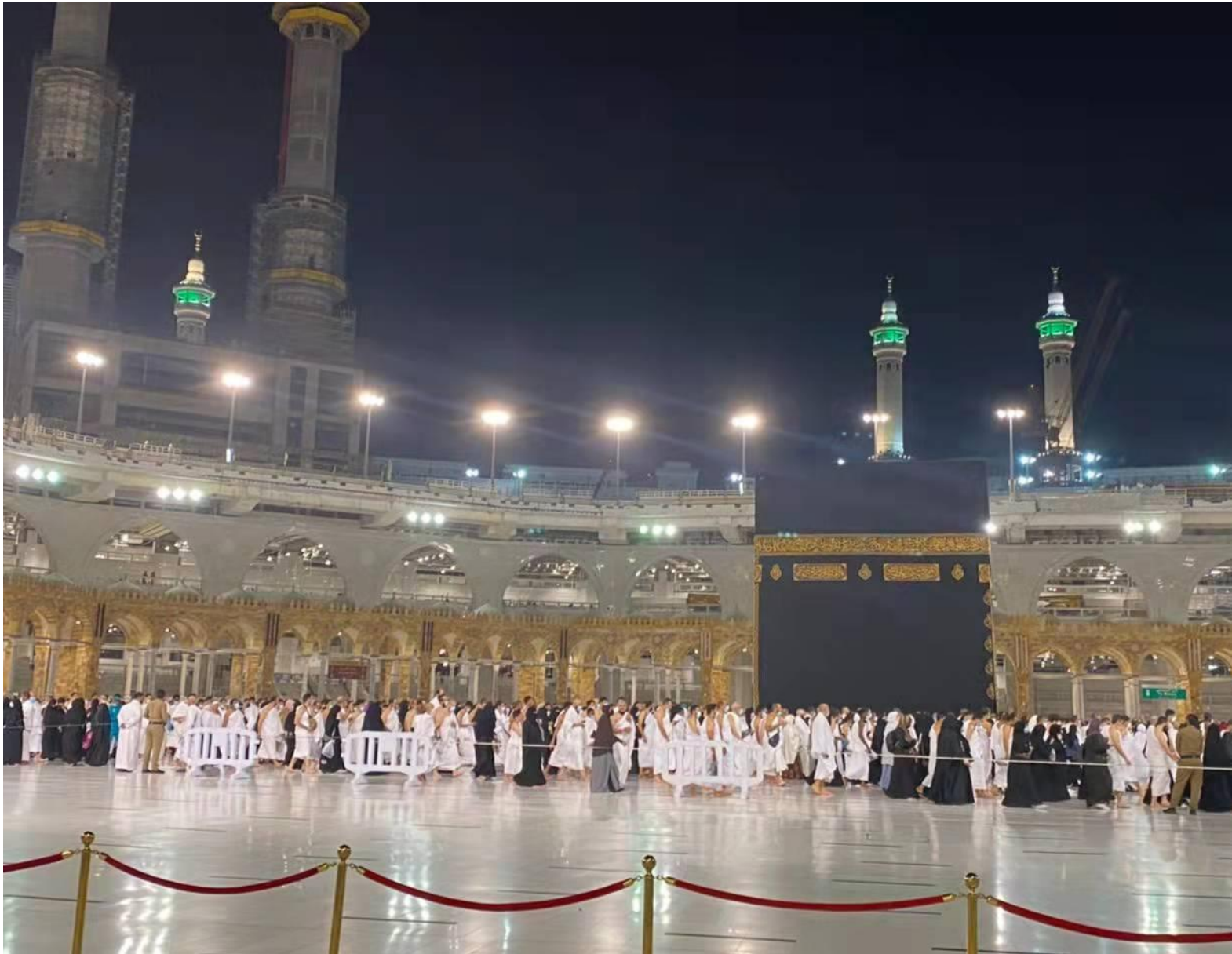

Project Reference



INS Series Flood Light
Ski Resort Lighting Project



Project Reference



Tennis Light
in Guangzhou School

Project Reference



Project Reference



Highbay Lighting-200W
Jousting Arena in USA

Project Reference



Highbay Lighting-150W
University Basketball Hall in USA

Project Reference

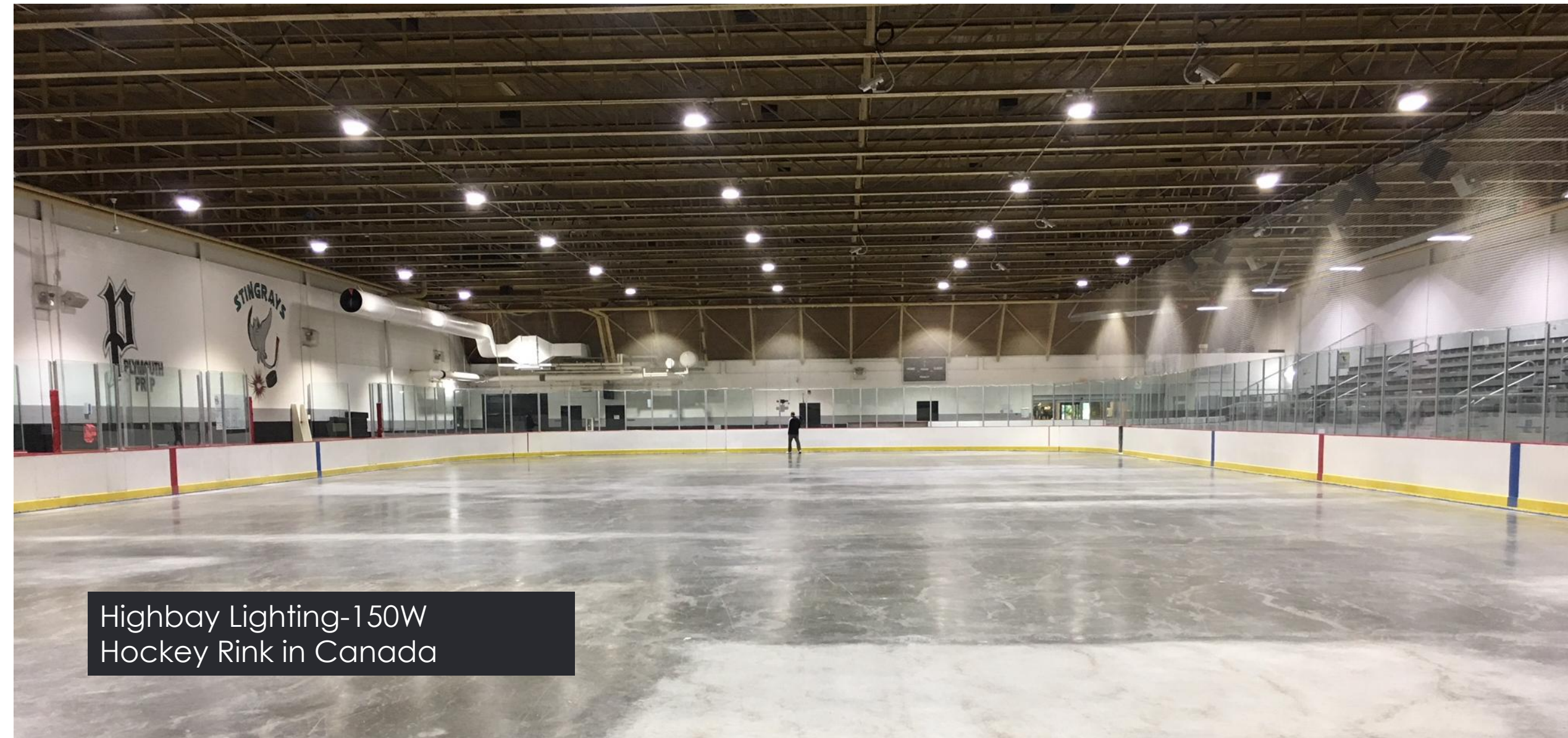

Highbay Lighting-150W
Hockey Rink in Canada



OVER YEARS 
10 EXPERIENCE

Thanks for
Watching

Since 2012

