

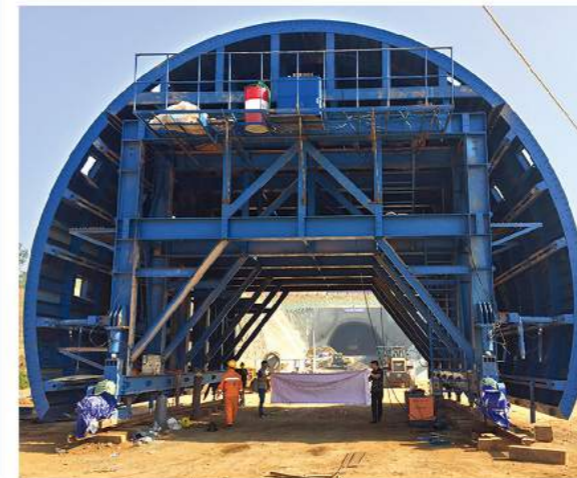

- | Engineering
- | Formwork
- | Scaffolding



Lianggong Formwork



Yancheng Lianggong Formwork Co.,Ltd

Add: No.8 Shanghai Road, Jianhu Economic Development Zone,
Yancheng City, Jiangsu Province, China
Tel: +86-515-86259636
Fax: +86-515-80663528
E-mail: lianggongformwork@gmail.com
Http: //www.lianggongform.com





COMPANY PROFILE

Yancheng Lianggong Formwork

Yancheng Lianggong Formwork Co., Ltd is one of the leading formwork and scaffolding companies located in Jianhu Economic Development Zone of Yancheng City, Jiangsu Province. As a well-established company in construction formwork field, Lianggong has been devoted itself and specialized in formwork and scaffolding research, development, manufacturing, and labor service.

During the years of hardworking since 2010 by the whole company staff, Lianggong has successfully delivered and served a large number of projects at home and abroad, such as bridges, tunnels, power stations, and industrial & civil constructions. Major products of Lianggong include H20 timber beam, wall and column formwork, single-sided bracket, crane-lifted climbing formwork, hydraulic auto-climbing system, protection screen and unloading platform, shaft beam platform, table formwork, ring-lock scaffolding and stair tower, cantilever forming traveller and hydraulic tunnel lining trolley, etc.

Utilizing its strong technical background and abundant engineering experience, and always bearing in mind to keep its cost-effectiveness and efficiency for clients, Lianggong will continue to be your best partner in any project from the very start and achieve higher and further goals together.



Achievements and Qualifications

LIANGGONG formwork according to ISO9001 quality management system as the company's core standards to ensure the continuous improvement of management level and business processes.





Quality Assurance

Each production process under control

Following the quality policy of "advanced technology, elaborative manufacturing, strict management and persistent improvement", we set up the brand of Lianggong with outstanding quality, taking the API Q1 and ISO9001 system as our standards and guidelines.

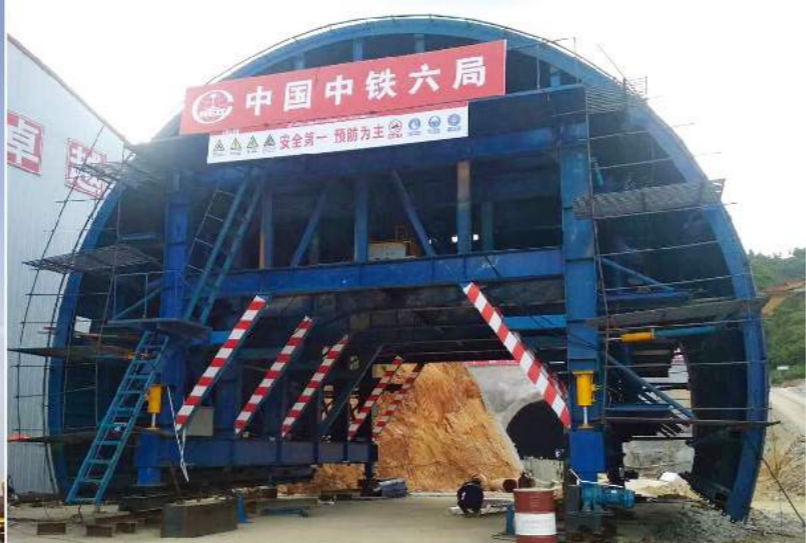

Vertical Systems:

H20 Timber Beam and Formwork Systems	01
Hydraulic Auto-climbing System (HCB-100 & HCB-120)	13
Cantilever Climbing Formwork (CB-180 & CB-240)	29
Protection Screen and Unloading Platform	39
Single-side Bracket	44
Shaft Beam Platform	49

Horizontal Systems:

Table Formwork	55
Flex-table Formwork System	67
Ring-lock Scaffolding and Stair Tower	68
Steel Prop and Tripod	80
Scaffolding Tower	83

Trolleys:

Pipe Gallery Trolley	87
Hydraulic Tunnel Lining Trolley	94

Others:

Other Formworks	97
Accessories	100

H20 Timber Beam and Formwork Systems

H20 Timber Beam

At present, we have a large-scale timber beam workshop and a first-class production line with daily output of over 4000m.



Timber beam product to be delivered



- **High quality**
Raw materials imported
- **Super performance**
Fully automatic finger jointing
- **High standard**
Manufactured on production lines





Timber beam lengthening

Standard holes can be punched on both ends of the timber beam. On project site, the timber beam can be lengthened as per need. We can also produce customer-made timber beams at any length.



Timber beam end protection

The timber beams is an important part of the formwork system and widely used in engineering projects. In order to protect the timber beam from being damaged and extend the service life, we've designed the following four end caps for your choice.



Iron half protection end cap



Iron full protection end cap



Plastic half protection end cap



Plastic full protection end cap

Specifications of H20 timber beams:

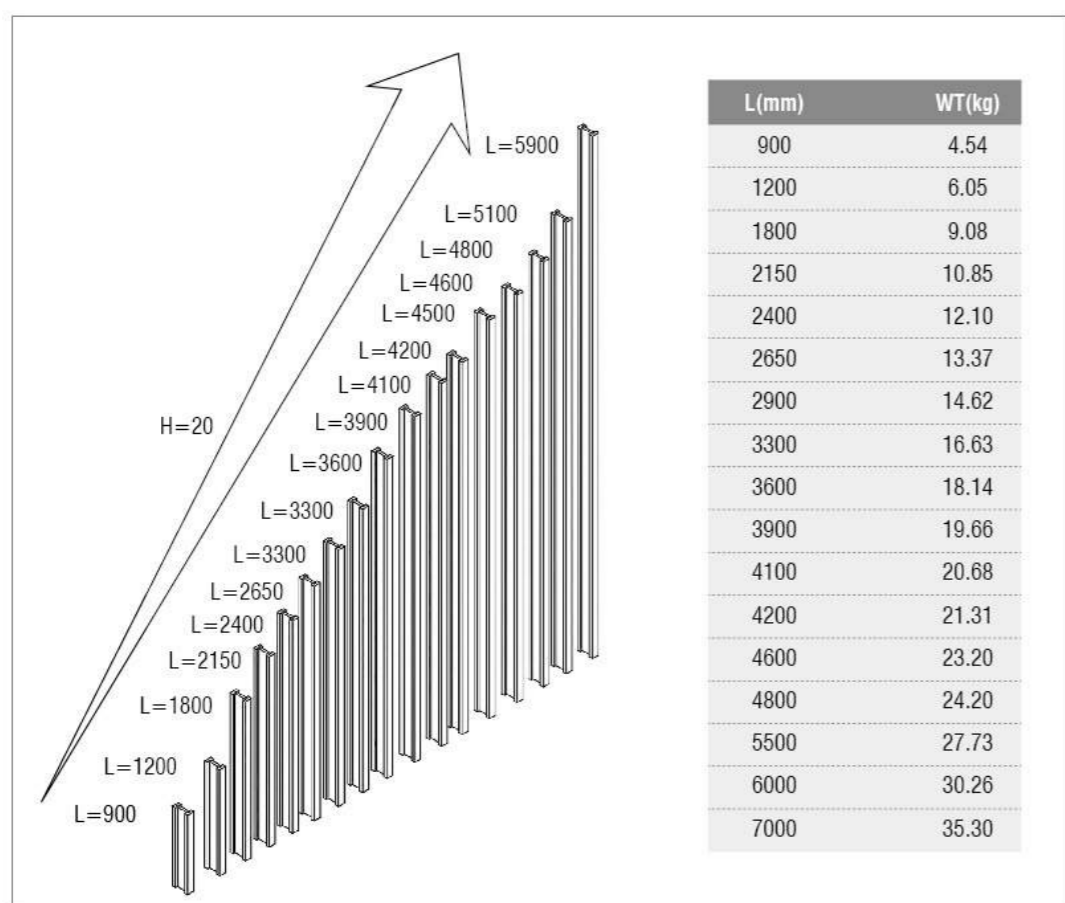

Parameters of timber beams:

Permitted bending moment	Permitted shearing force	Average weight
5KN*m	11KN	4.8-5.2kg/m

Timber Beam Formwork



The assembly process

Positioning of walers

Lay walers on the platform at the distance shown in the drawing. Mark the positioning line on the walers and draw the diagonal lines. Let the diagonal lines of the rectangle that is composed by any two walers equal to each other.

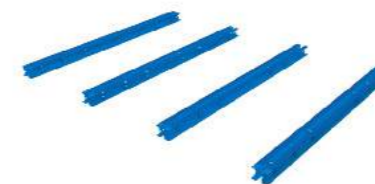

Timber beam assembling

Lay a timber beam at both ends of the waler according to the dimension shown in the drawing. Mark the positioning line and draw the diagonal lines. Make sure the diagonal lines of the rectangle that is composed by two timber beams equal to each other. Then fix them by flange clamps. Connect the same end of the two timber beams by a thin line as the benchmark line. Lay other timber beams according to the benchmark line and ensure that they are parallel to timber beams on both sides. Fix each timber beam with clamps.

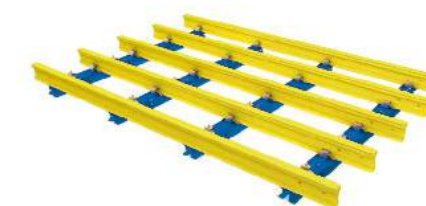

Flat formwork

The flat formwork system consists of plywood, H20 timber beam, steel waler and lifting hook. The plywood and the timber beam are connected by the self-tapping screw. Steel waler and timber beam are connected with flange clamp. Two hooks are arranged symmetrically on both sides of the timber beam. The timber beam is assembled on site by standardized accessories, which is convenient for disassembly and assembly. It is light in weight and convenient for construction and transportation. The formwork panel is plywood, and the board surface is smooth, being good for water absorption and air transmission. Without being tainted, the concrete surface has good appearance, in high quality and turnover rates. Thus, it has been widely used in walls, columns, piers and dams.

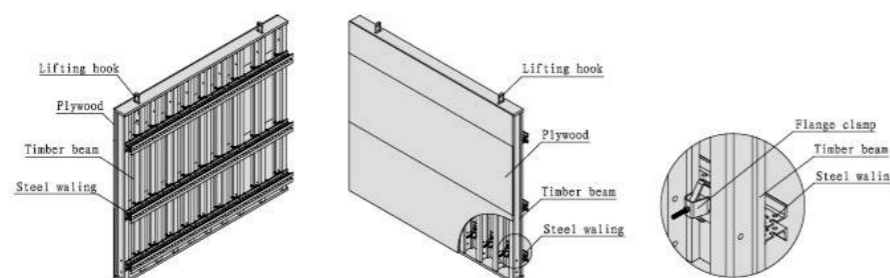

Installing lifting hook on timber beam

Install lifting hooks according to the dimension on the drawing. Clamps must be used on both sides of the timber beam where the hook is located, and ensure that the clamps are fastened.



Laying panel

Cut the panel according to the drawing and connect the panel with the timber beam by self-tapping screws.

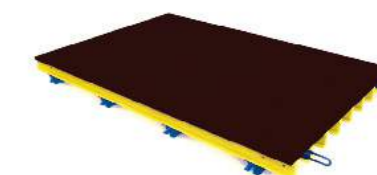

Stacking and storage of formwork

When panels and timber beams are stacked, used or transported, collision with hard objects must be avoided, so as to prevent from any damage to the formwork. In addition, they should not be exposed to rain or sunshine. The assembled formwork is stacked as shown in the figure.

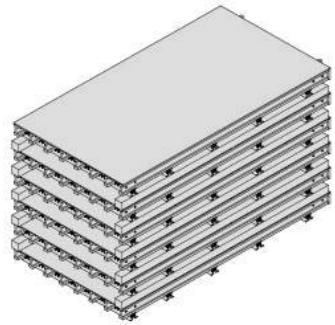

Assembled formwork on site



Formwork lifting

The assembled formwork can be lifted in a complete set as shown in the figure:

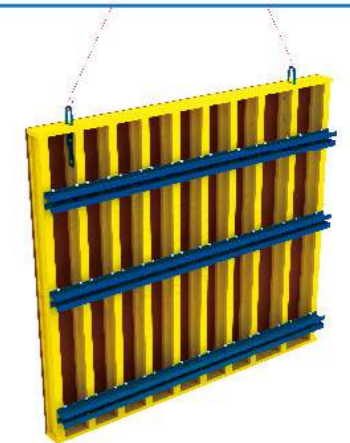

Adjustable arced formwork

Introduction

Plywood is utilized for the panel of adjustable arced formwork, as it has a certain toughness and can be deformed without being damaged after applying an appropriate external force. By taking its such features and geometric principles, the adjustment system is used to bend the panel into the designed arcs. The adjacent adjustable arced formwork unit can be seamlessly connected by adjustable frame clamps. This formwork system is suitable for any arced piers with radius longer than 2 meters.

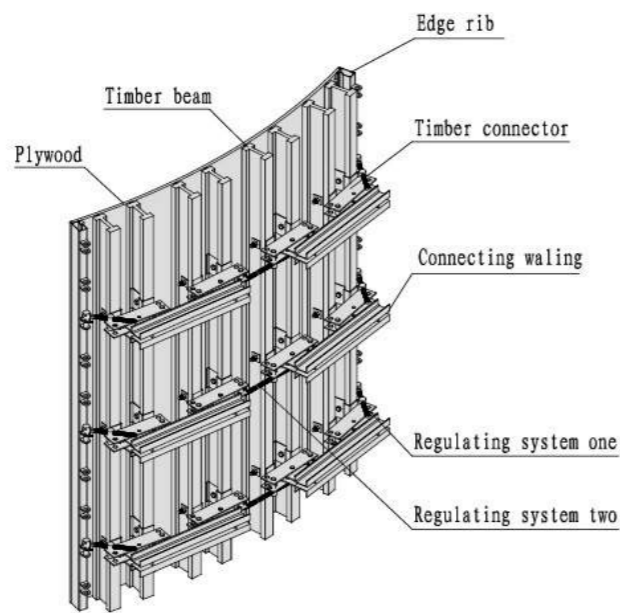

Assembly process

- ◆ Assembly of timber beam and timber beam connector
- ◆ Assembly of plywood and frame
- ◆ Assembly of adjusting system
- ◆ Assembly of connecting seats
- ◆ Overall adjustment: The formwork is bent by the adjusting system until the bending radii of the formwork reaches the expected design value.

Adjustable arced formwork lifting

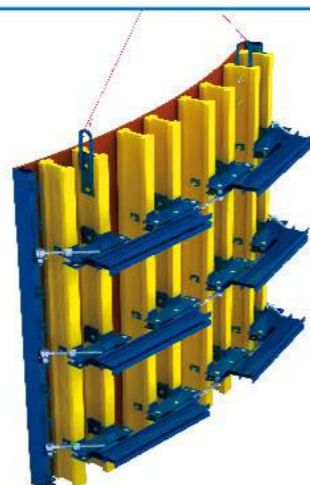

Project application of adjustable arced formwork



Column formwork

The timber beam column formwork is mainly used for casting columns, and its structure and connecting way are quite similar to that of wall formwork.

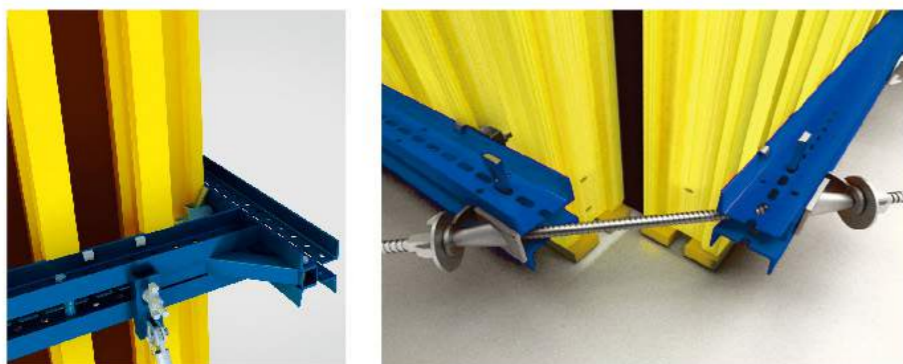

It can be adjusted to any cross-section size within the allowable range, both square and rectangular. The schematic diagram of adjustment is as follows:

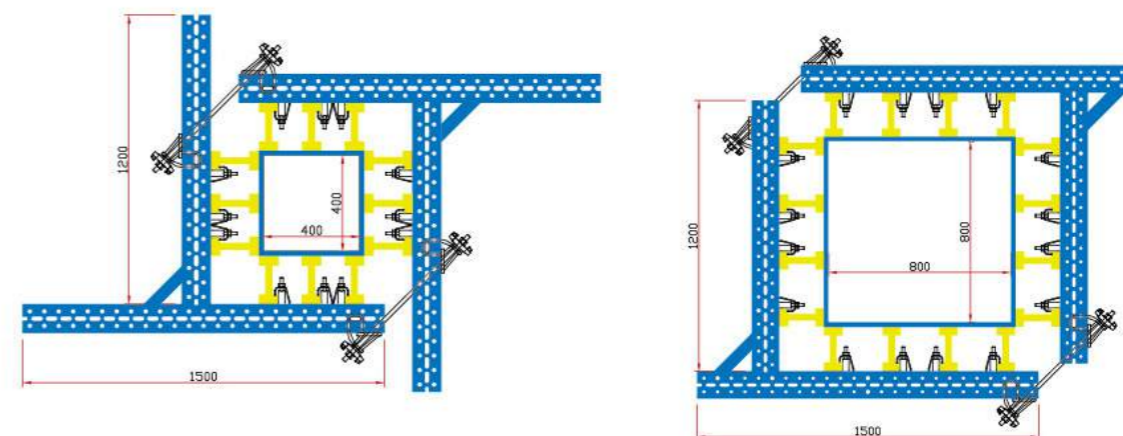

Wall diagonal brace

The timber beam wall column formwork needs to be equipped with a spindle strut, which is used as an adjusting system as shown in the figure:

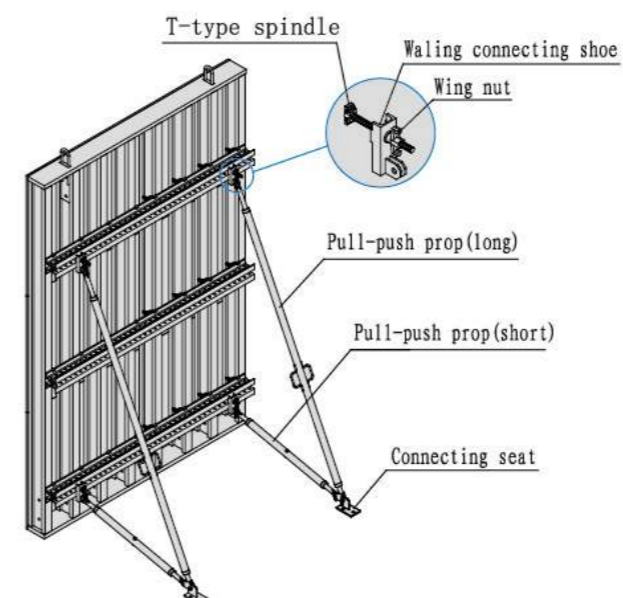

Adjustable column formwork

The adjustable column formwork enables concrete casting of square or rectangular columns within a specific range by adjusting the size of the formwork section area. The adjustment is realized by changing the relative position of the walers.

There are three specifications for the walers of adjustable column formwork, which can do concrete casting of square or rectangular columns with side length of 200-1400mm. Sizes of column to be casted as follows:

Length of waler (m)	Scope of side length of column to be casted (m)
1.6 and 1.9	1.0 ~ 1.4
1.6 and 1.3	0.6 ~ 1.0
1.3 and 0.9	0.2 ~ 0.6

Hydraulic Auto-Climbing System

The preferred formwork system for high-rise building and bridge construction

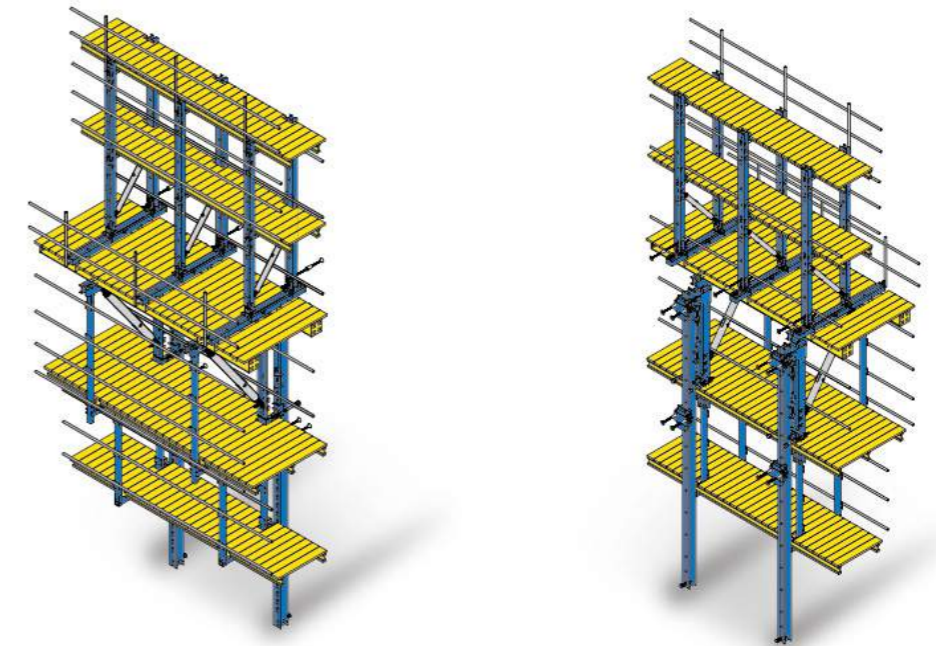

Introduction

The hydraulic auto-climbing formwork system (ACS) is a wall-attached self-climbing formwork system, which is powered by its own hydraulic lifting system. The formwork system (ACS) includes a hydraulic cylinder, an upper and lower commutator, which can switch the lifting power on the main bracket or climbing rail. With the power by the hydraulic system, the main bracket and climbing rail are able to climb respectively. Therefore, the complete hydraulic auto-climbing system (ACS) climbs steadily without crane. No other lifting device is needed when using the hydraulic auto-climbing formwork, which has the advantages of being easy to operate, fast and safe in the climbing process. ACS is the first-choice formwork system for high-rise tower and bridge construction.

Characteristics

- Hydraulic auto-climbing formwork can climb as a complete set or individually. The climbing process is steady, synchronous and safe.
- The brackets of the auto-climbing formwork system will not be dismantled until the construction period finished, thus saving space for the site and avoiding damage to the formwork, especially to the panel.
- It provides all-round operating platforms. The contractors do not need to set up other operating platforms, thus saving the cost on material and labor, and improving safety
- The error of structure construction is small. As work on correction is simple, the construction error can be eliminated floor by floor.
- The climbing speed of the formwork system is fast. It can speed up the whole construction work (average 5 days for one floor).
- The formwork can climb by itself and cleaning work can be done in situ, so that the use of tower crane will be greatly reduced.

Two types of hydraulic auto-climbing formworks: HCB-100 & HCB-120

Structure diagram of diagonal brace type

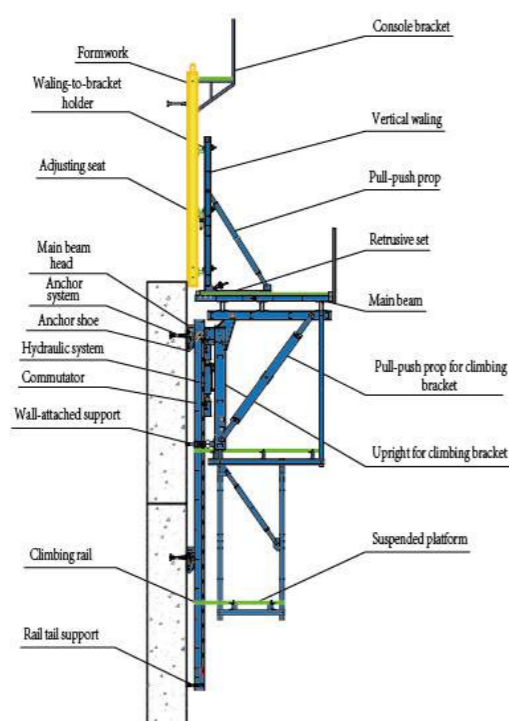

Structure diagram of truss type

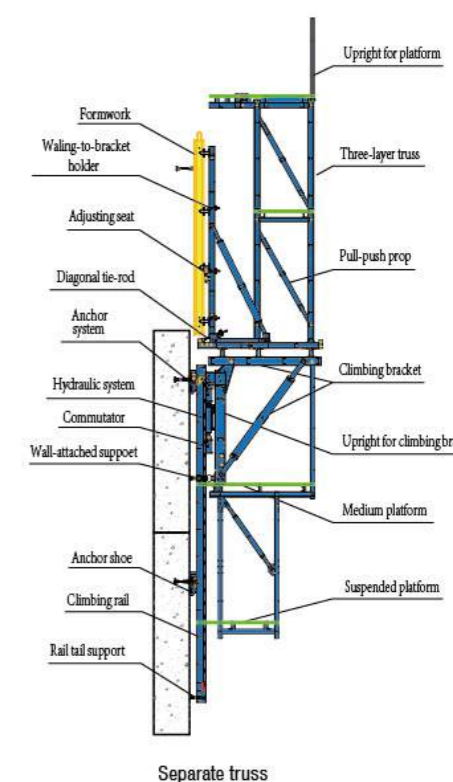
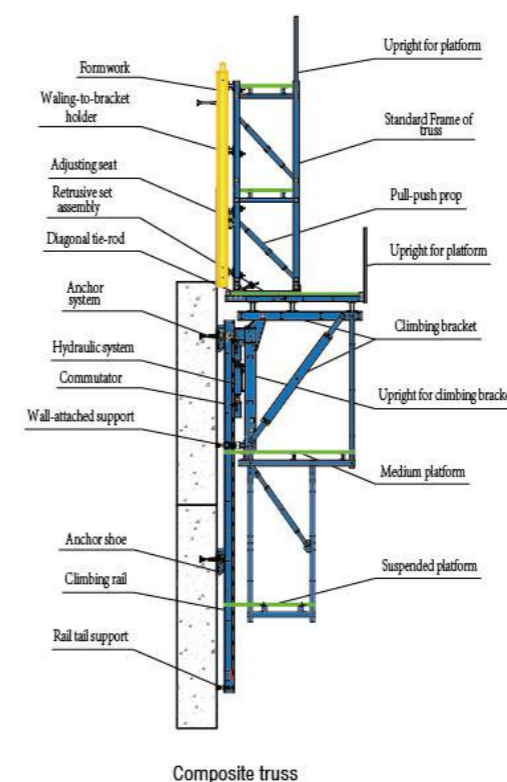

Main function indicators

Construction load:

- ◆ Top platform $\leq 0.75\text{KN/m}^2$
- ◆ Other platform $\leq 1\text{KN/m}^2$

Electronically controlled hydraulic lifting system

- ◆ Cylinder stroke: 300mm;
- ◆ Hydraulic pump station flow: $n \times 2\text{L/min}$, n is the number of seats;
- ◆ Stretching speed: about 300mm/min;
- ◆ Rated thrust: 100KN & 120KN;
- ◆ Double cylinder synchronization error: $\leq 20\text{mm}$



Main function indicators

Construction load:

- ◆ Top platform $\leq 4\text{KN/m}^2$
- ◆ Other platform $\leq 1\text{KN/m}^2$

Electronically controlled hydraulic lifting system

- ◆ Cylinder stroke: 300mm;
- ◆ Hydraulic pump station flow: $n \times 2\text{L/min}$, n is the number of seats;
- ◆ Stretching speed: about 300mm/min;
- ◆ Rated thrust: 100KN & 120KN;
- ◆ Double cylinder synchronization error: $\leq 20\text{mm}$



Introduction to systems of hydraulic auto-climbing formwork

Anchor system

Anchor system is the load bearing system of the whole formwork system. It consists of tensile bolt, washer, climbing cone, high-strength tie rod and anchor plate. The anchor system is divided into two types, A and B, which can be selected according to requirements.

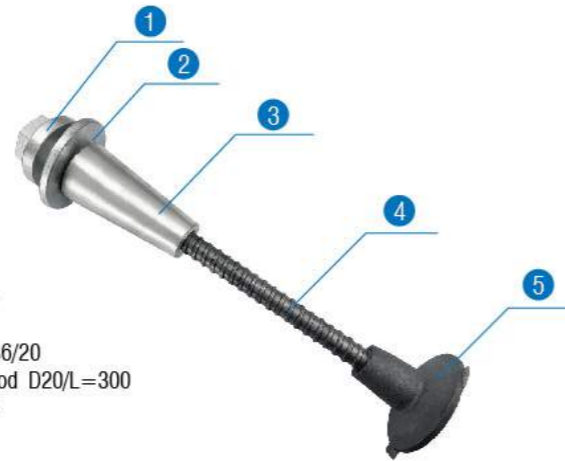

Anchor system A

- ① Tensile bolt M42
- ② Washer
- ③ Climbing cone M42/26.5
- ④ High-strength tie rod D26.5/L=300
- ⑤ Anchor plate D26.5

Anchor system B

- ① Tensile bolt M36
- ② Washer
- ③ Climbing cone M36/20
- ④ High-strength tie rod D20/L=300
- ⑤ Anchor plate D20

Standard components

Load-bearing bracket

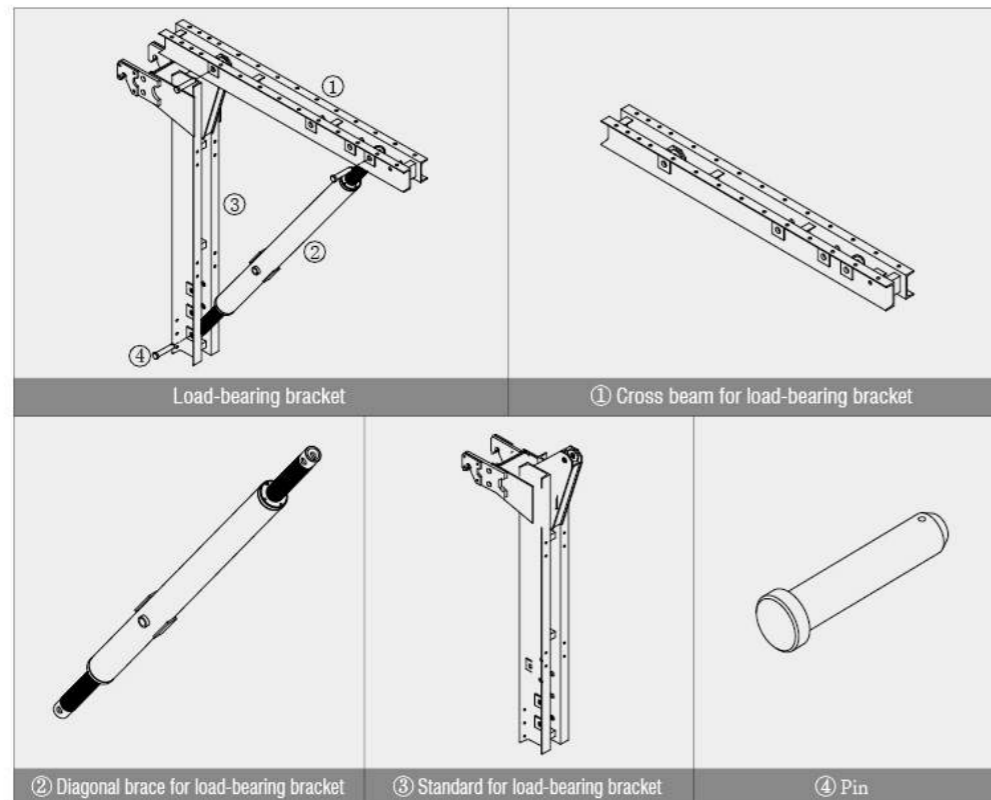

Retrusive set

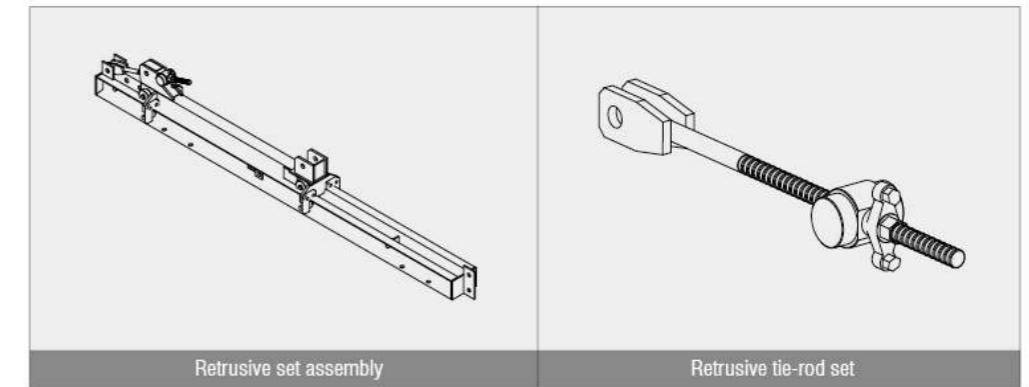

Medium platform

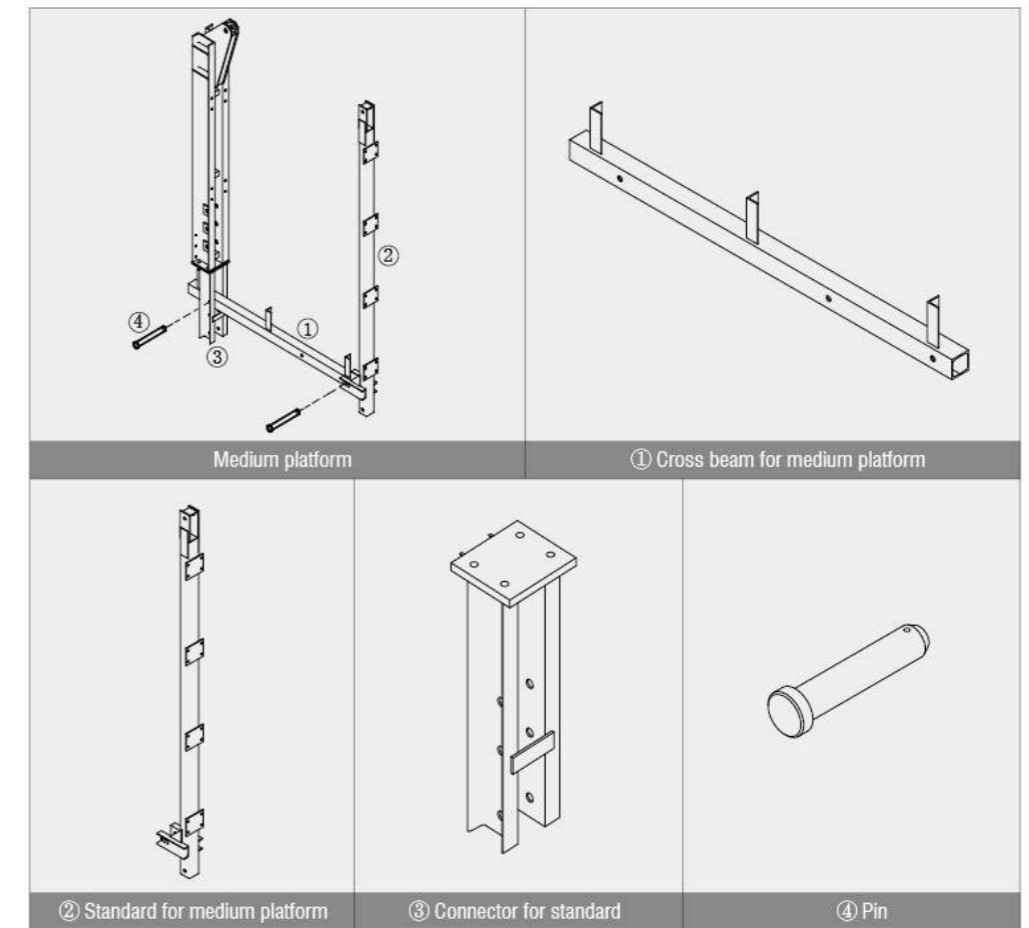

Wall-attached device

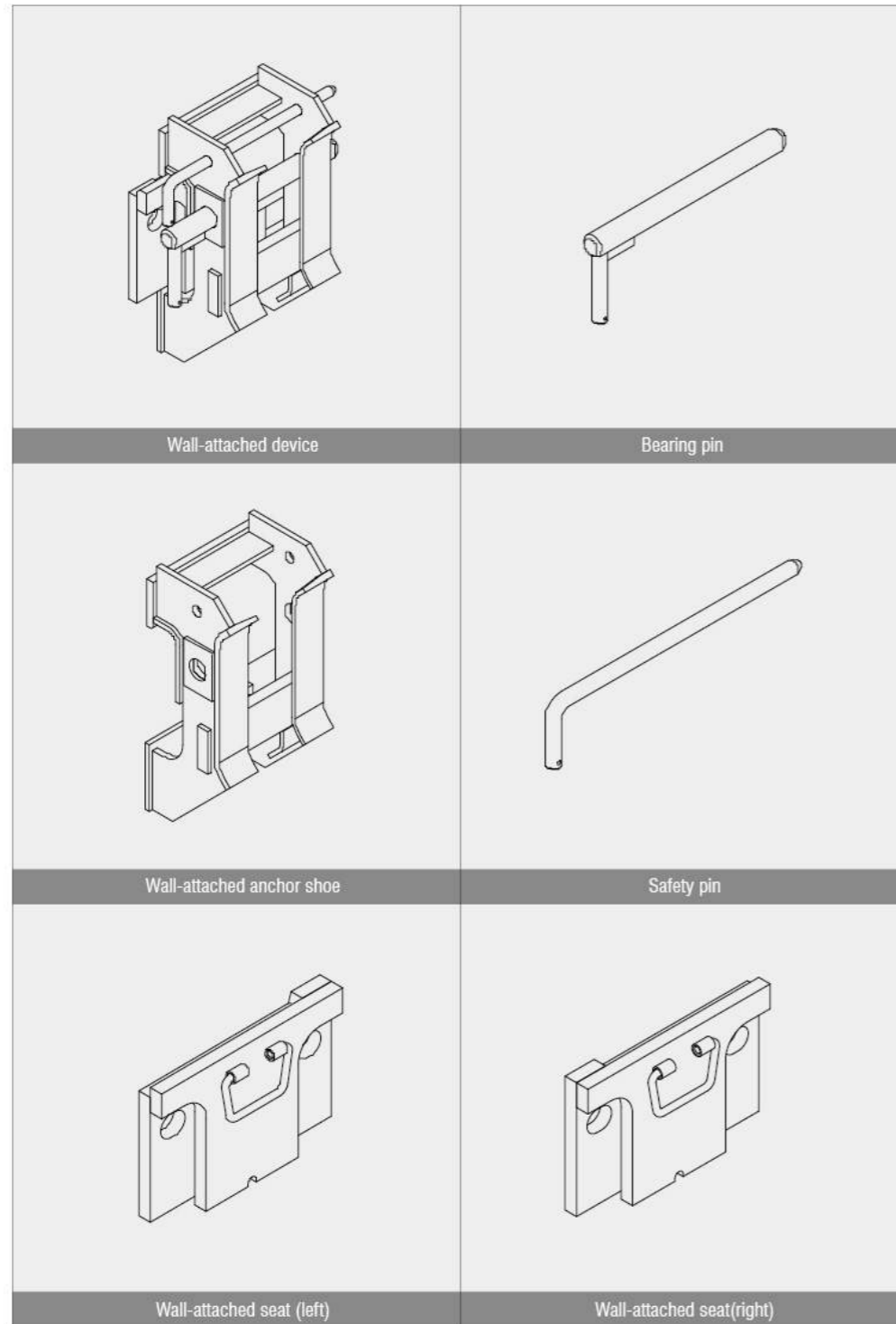

Climbing rail

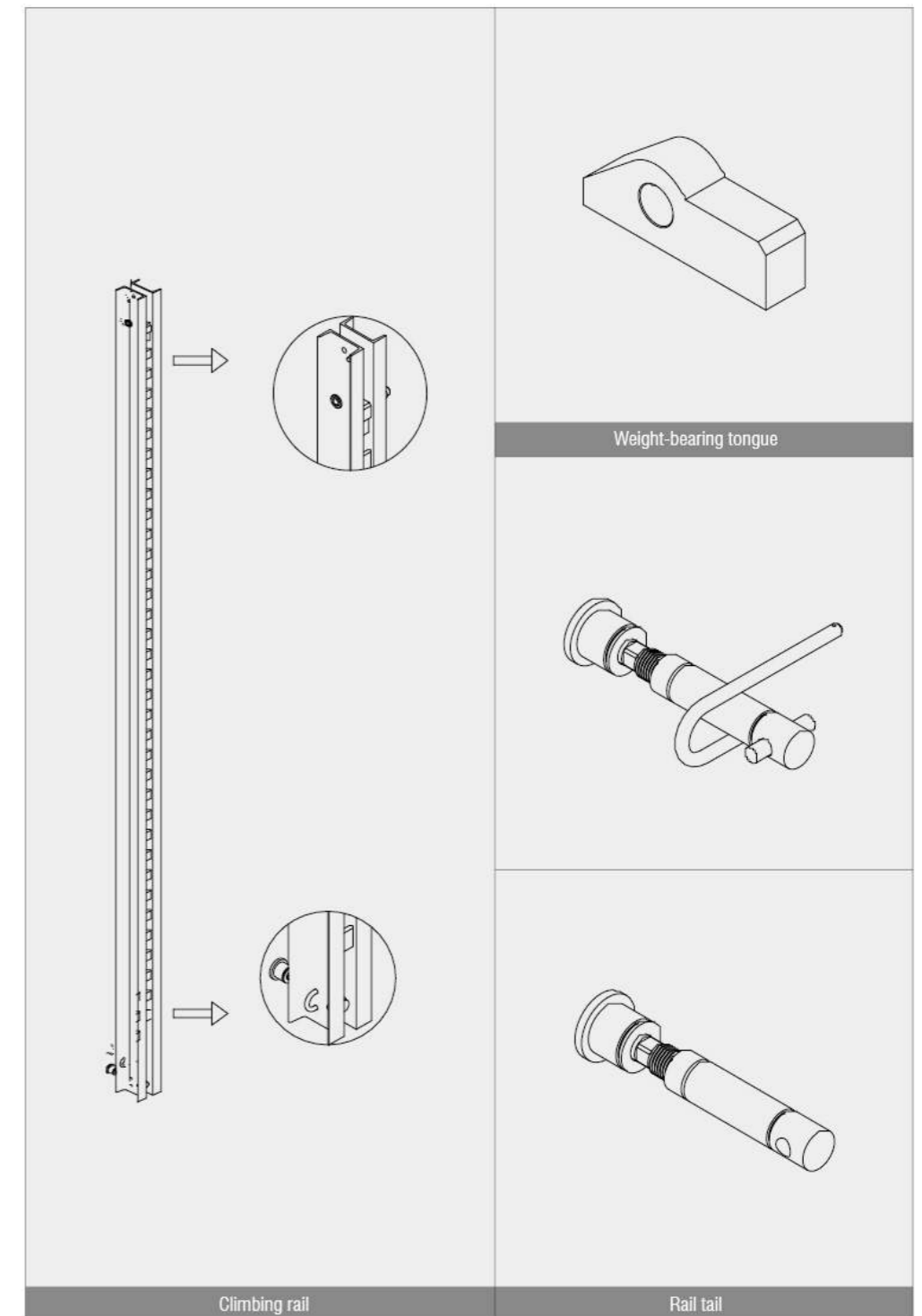

Suspended platform

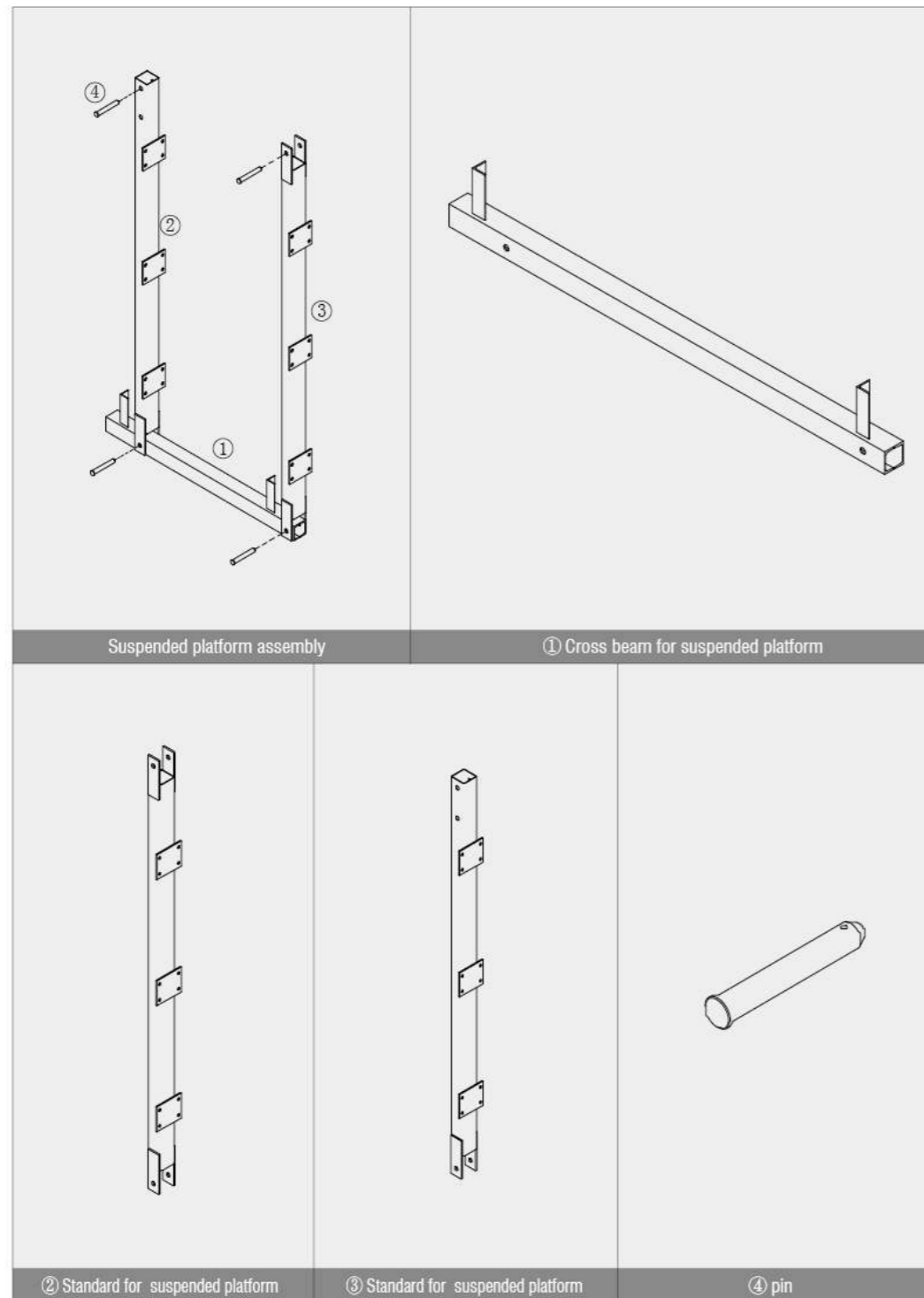

Main waler

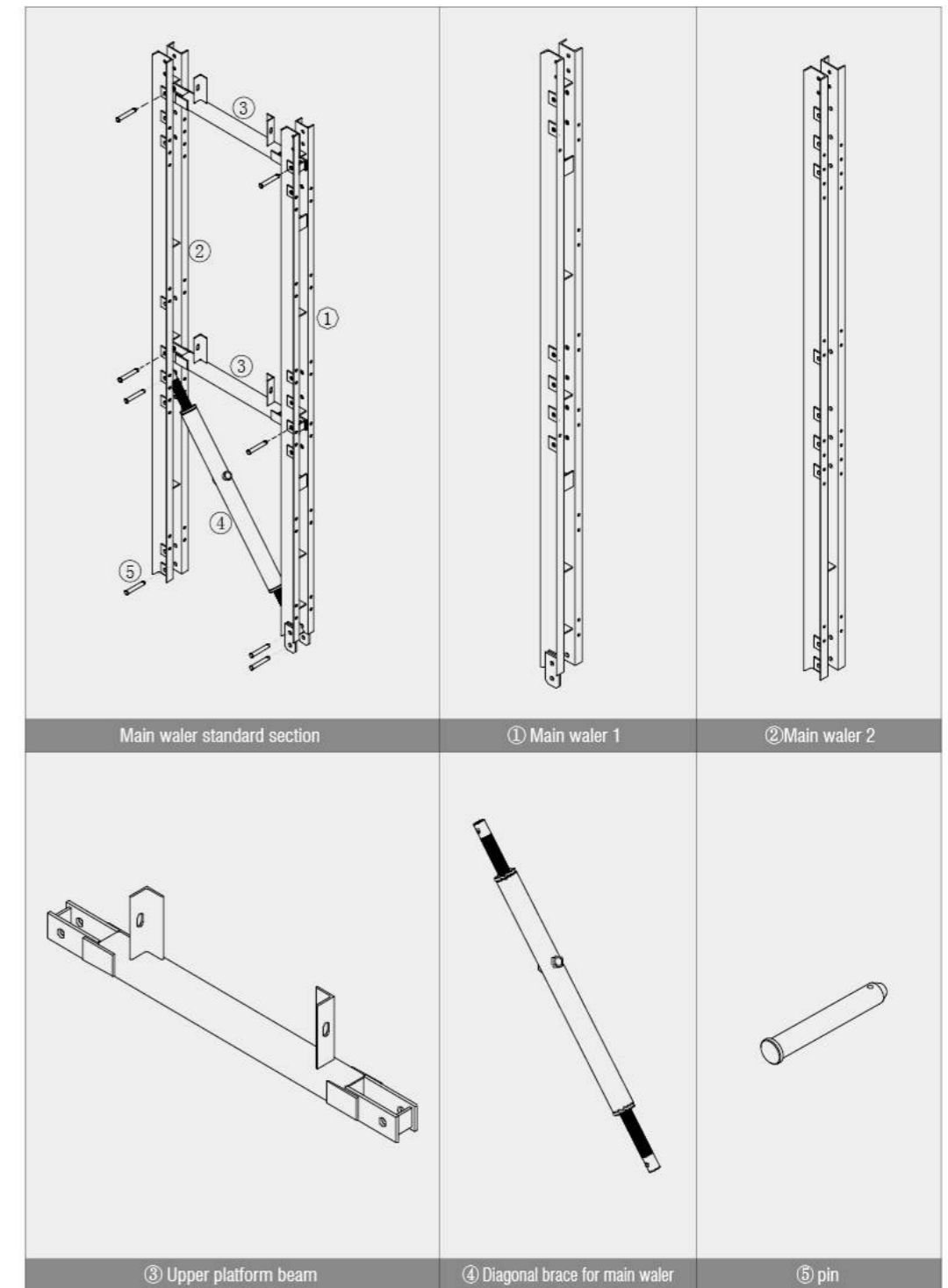

Accessories

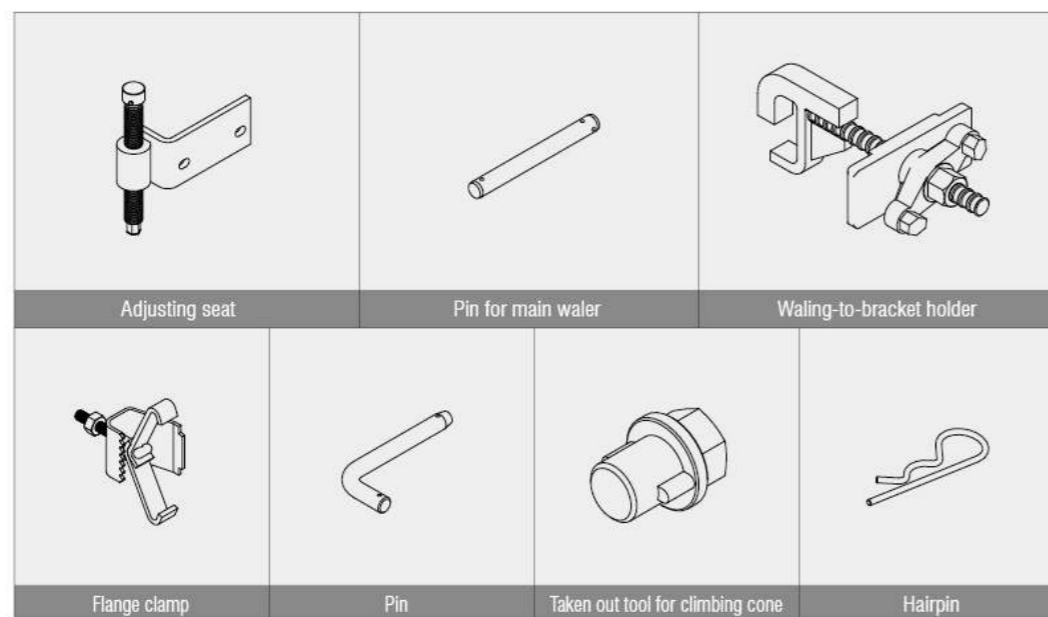

Hydraulic system



The hydraulic system consists of commutator, hydraulic system and power distribution device. The upper and lower commutator are important components for the force transmission between the bracket and the climbing rail. Changing the direction of the commutator can realize the respective climbing of the bracket and climbing rail.

Assembly process

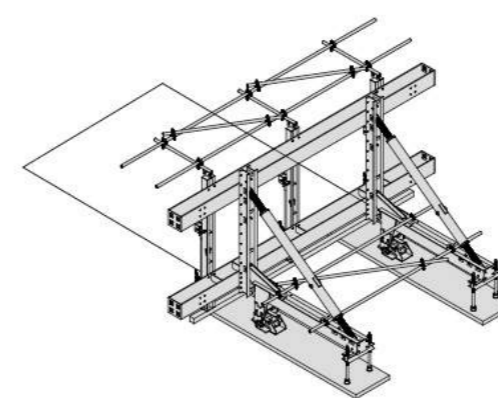

① Bracket assembly

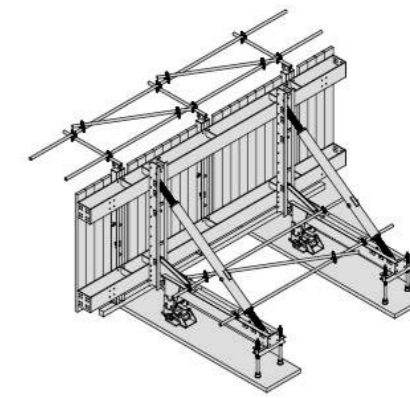

② Platform installation

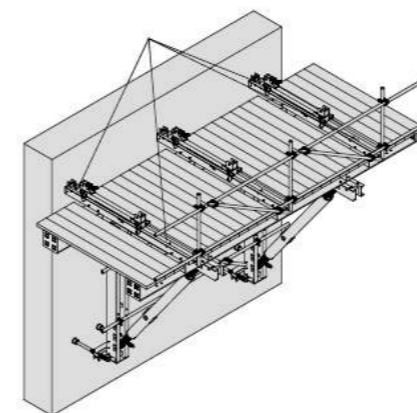

③ Bracket lifting

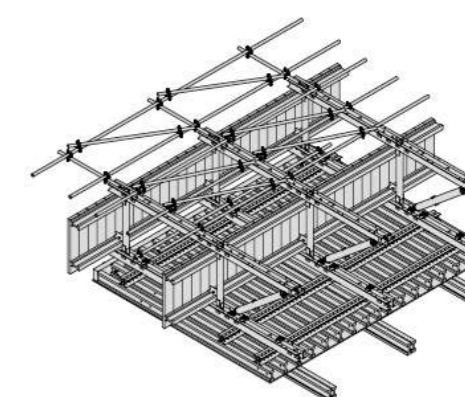

④ Truss assembly and operation platform installation

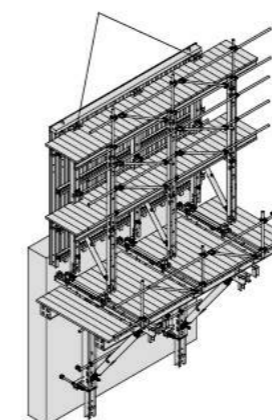

⑤ Truss and formwork lifting

Project application of hydraulic auto-climbing formwork



Project name: Shenyang Baoneng Global Financial Center T1、T2
Contractor: CSCEC, Third Bureau
Products utilized: ACS, HCB-100 (Separate Truss Type)



Project name: Harmonious Century Square
Contractor: Yunnan Jiangdong Group Construction Engineering Co., Ltd. First Engineering Office
Products utilized: ACS, HCB-100 (Separate Truss Type)



Project name: Zhongyu International Building
Contractor: Jiangsu Hongsheng Group, Suzhou Six Branch
Products utilized: ACS, HCB-100 (Separate Truss Type)



Project name: Bengbu Sports Center Landscape Tower
Contractor: CSCEC, 8th Bureau
Products utilized: ACS, HCB-100 (Separate Truss Type)

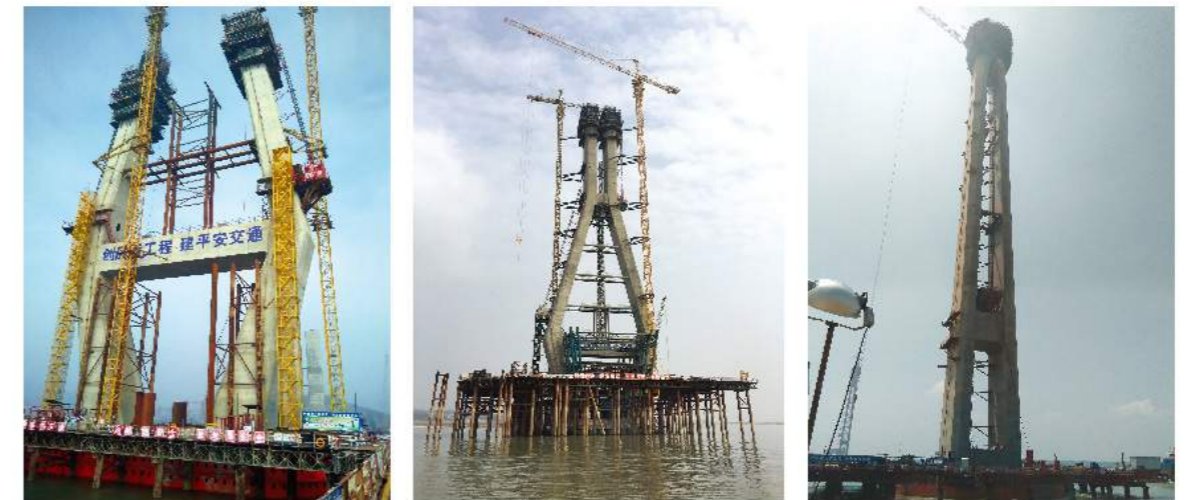

Project name: Yueqing Bay No. 2 Bridge
Contractor: China Communications First Highway Engineering Co., Ltd.
Products utilized: ACS, HCB-100 (Composite Truss Type)

Project name: Poyang Lake Bridge
Contractor: South China Engineering Co., Ltd. of China Communications Road and Bridge Construction Co., Ltd.
Products utilized: ACS, HCB-100 (Composite Truss Type)

Project name: Wuhu Second Bridge on Yangtze River
Contractor: China Railway Bridge Bureau Fourth Engineering Co., Ltd.
Products utilized: ACS, HCB-100 (Separate Truss Type)



Project name: Polonggou Bridge
Contractor: China Railway Bridge Corporation
Products utilized: ACS, HCB-100 (Composite Truss Type)



Project name: Section 1, 2, 3 of the main channel of Zhoushan Port, Ningbo
Contractor: Zhejiang Jiaogong Group Co., Ltd. CSCEC China Communications Road and Bridge Construction Co., Ltd.
Products utilized: ACS, HCB-100 (Separate Truss Type)



Project name: Yanpingba Yangtze River Bridge
Contractor: Sichuan Highway Bridge Construction Group Co., Ltd.
Products utilized: ACS, HCB-100 (Separate Truss Type)



Project name: Oubei Bridge
Contractor: China Communications First Public Administration, Second Engineering Co., Ltd.
Products utilized: ACS, HCB-100 (Composite Truss Type)



Project name: Wangdong Yangtze River Highway Bridge
Contractor: South China Engineering Co., Ltd. of China Communications Road and Bridge Construction Co., Ltd.
Products utilized: ACS, HCB-100 (Composite Truss Type)

Cantilever Climbing Formwork



CB-180 & CB-240

Introduction

The cantilever climbing formwork, CB-180 and CB-240, are mainly used for large-area concrete pouring, such as for dams, piers, anchors, retaining walls, tunnels and basements. The lateral pressure of concrete is borne by anchors and wall-through tie rods, so that no other reinforcement is needed for the formwork. It is featured by its simple and quick operation, wide range adjustment for one-off casting height, smooth concrete surface, and economy and durability.

The cantilever climbing formwork CB-240 has lifting units in two types: diagonal brace type and truss type. Truss type is more suitable for the cases with heavier construction load, higher formwork erection and smaller scope of inclination.

The main difference between CB-180 and CB-240 is the main brackets. The width of main platform of these two systems is 180 cm and 240 cm respectively.

Characteristics

- ◆ Bracket, formwork and construction load are all borne by embedded anchors and wall-through tie rods. No additional scaffolding is needed. It is suitable for construction in the high air.
- ◆ The maximum height of concreting can reach 6 meters, and the whole part of formwork can be moved back 600 mm.
- ◆ The formwork part can be adjusted up and down, and from left to right, relatively to the supporting bracket, and the diagonal brace type formwork can be tilted back and forth.
- ◆ Each connecting parts has a high degree of standardization and versatility.
- ◆ The formwork can be adjusted to stick tightly to concrete surface so as to avoid leaking or misaligning.
- ◆ The bracket system is provided with a suspended platform to facilitate removal of the anchoring parts and the appearance treatment of the concrete.

Two types of cantilever climbing formwork : CB-180 & CB-240

Structure diagram of diagonal brace type

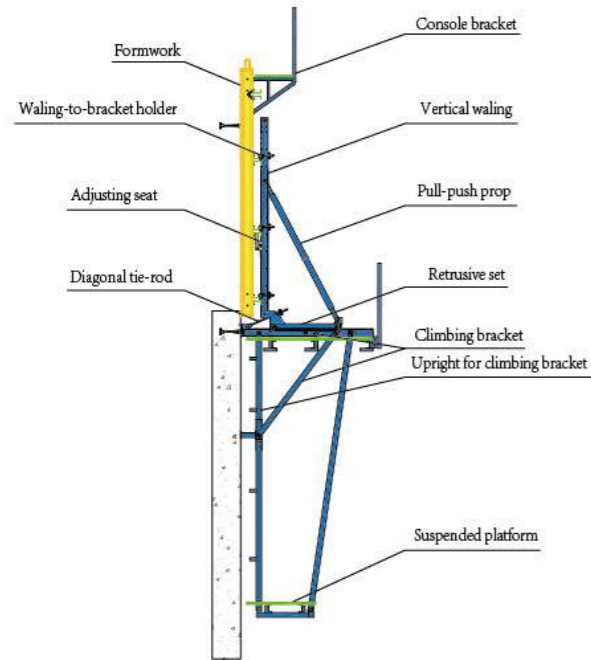

Structure diagram of truss type

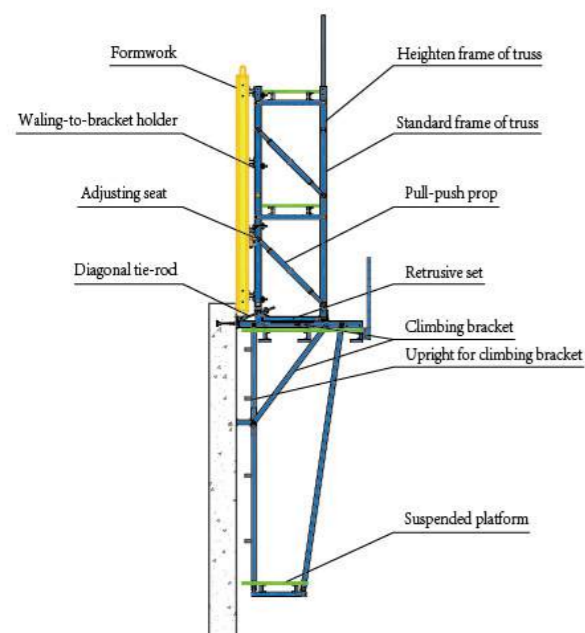

Introduction to systems of cantilever climbing formwork

Anchor system

Anchor system is the load bearing system of the whole formwork system. It consists of tensile bolt, Washer, climbing cone, high-strength tie rod and anchor plate. The anchor system is divided into two types, A and B, which can be selected according to requirements.

Anchor system A

- ① Tensile bolt M30
- ② Washer
- ③ Climbing cone M30/20
- ④ High-strength tie rod D20/L=300
- ⑤ Anchor plate D20

Anchor system B

- ① Tensile bolt M36
- ② Washer
- ③ Climbing cone M36/20
- ④ High-strength tie rod D20/L=300
- ⑤ Anchor plate D20



Standard components

Load-bearing bracket

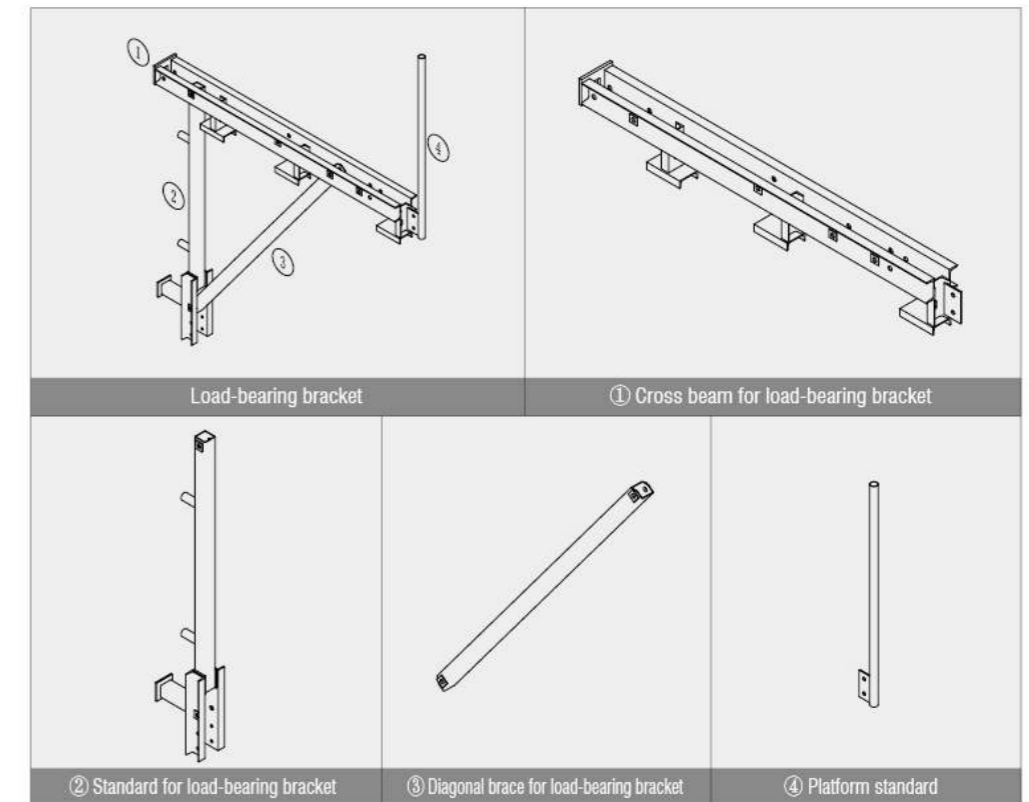

Retrusive set

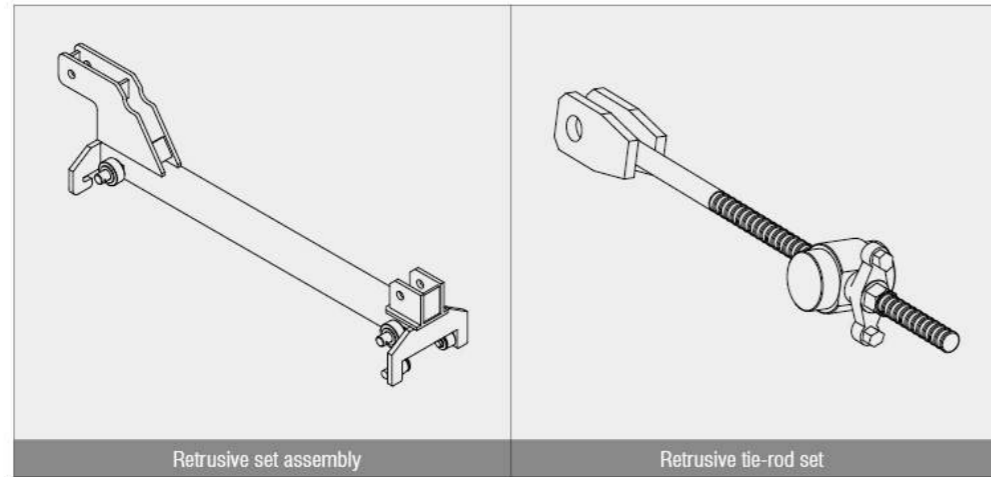

Retrusive set assembly

Retrusive tie-rod set

Main waler

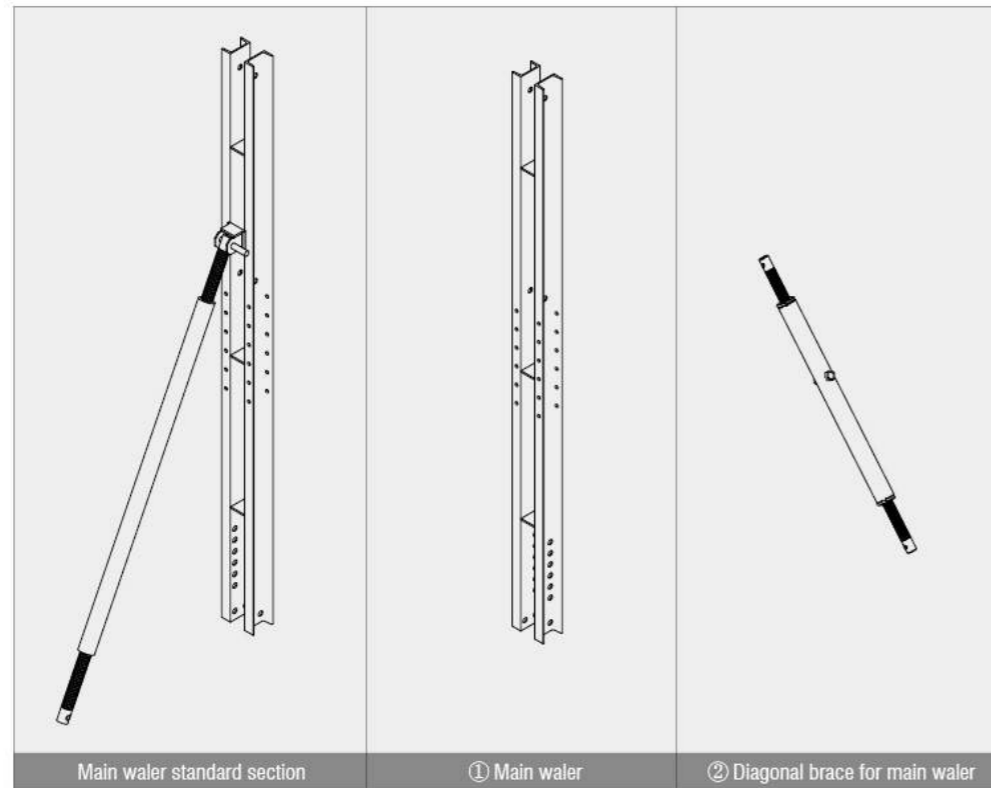

Main waler standard section

① Main waler

② Diagonal brace for main waler

Suspended platform

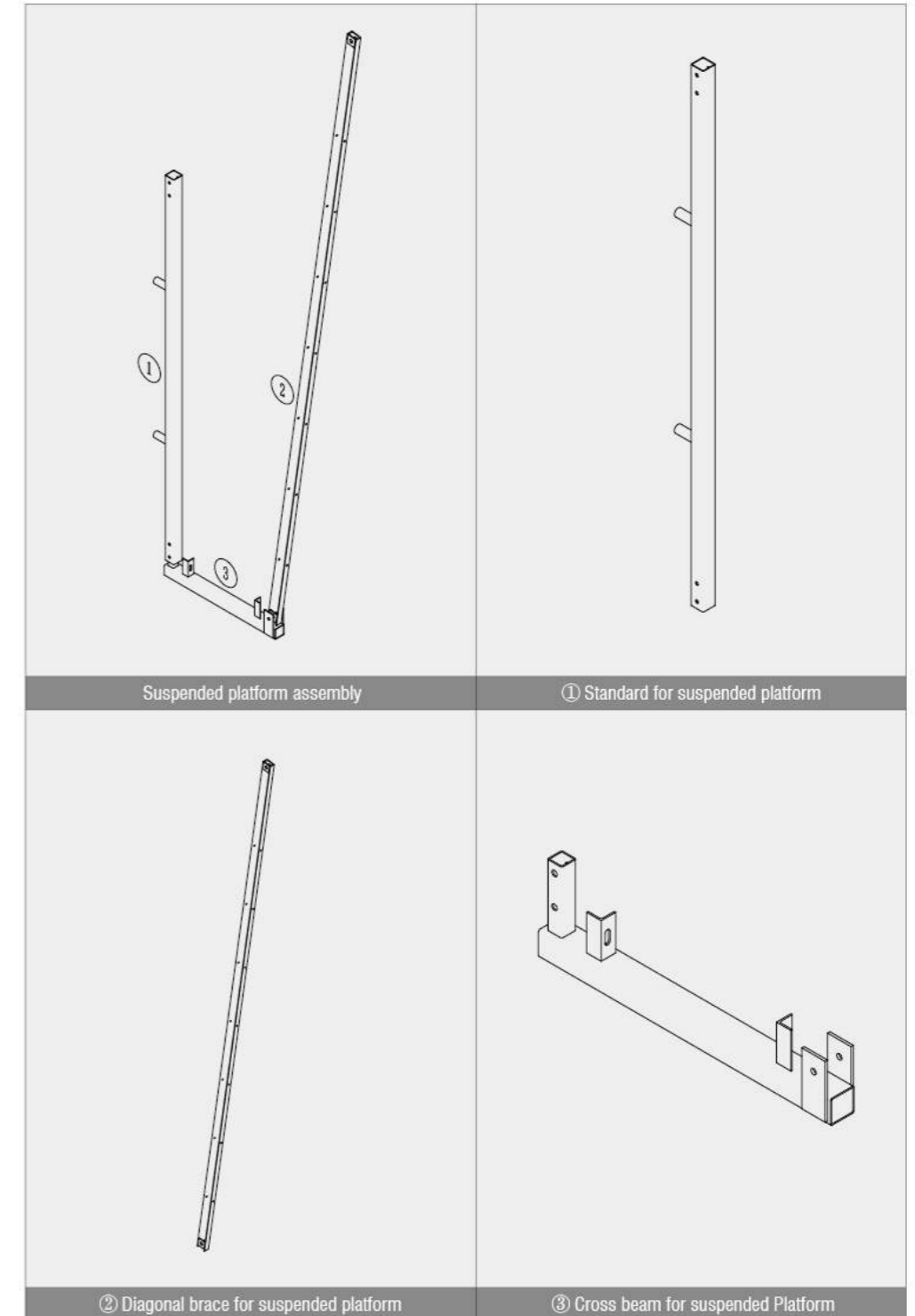

Suspended platform assembly

① Standard for suspended platform

② Diagonal brace for suspended platform

③ Cross beam for suspended Platform

Accessories

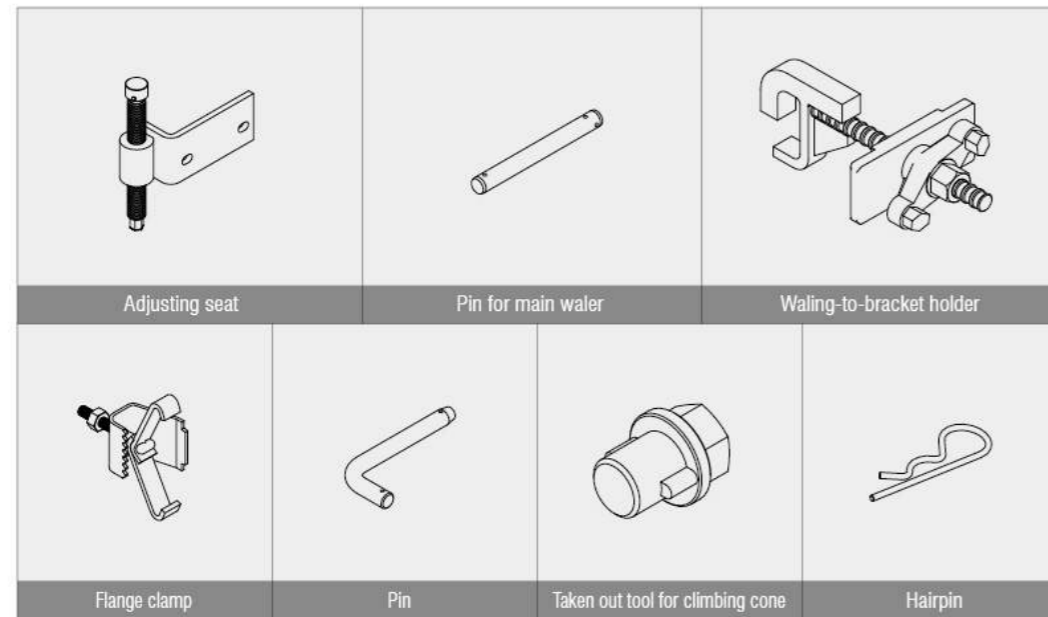

Assembly process

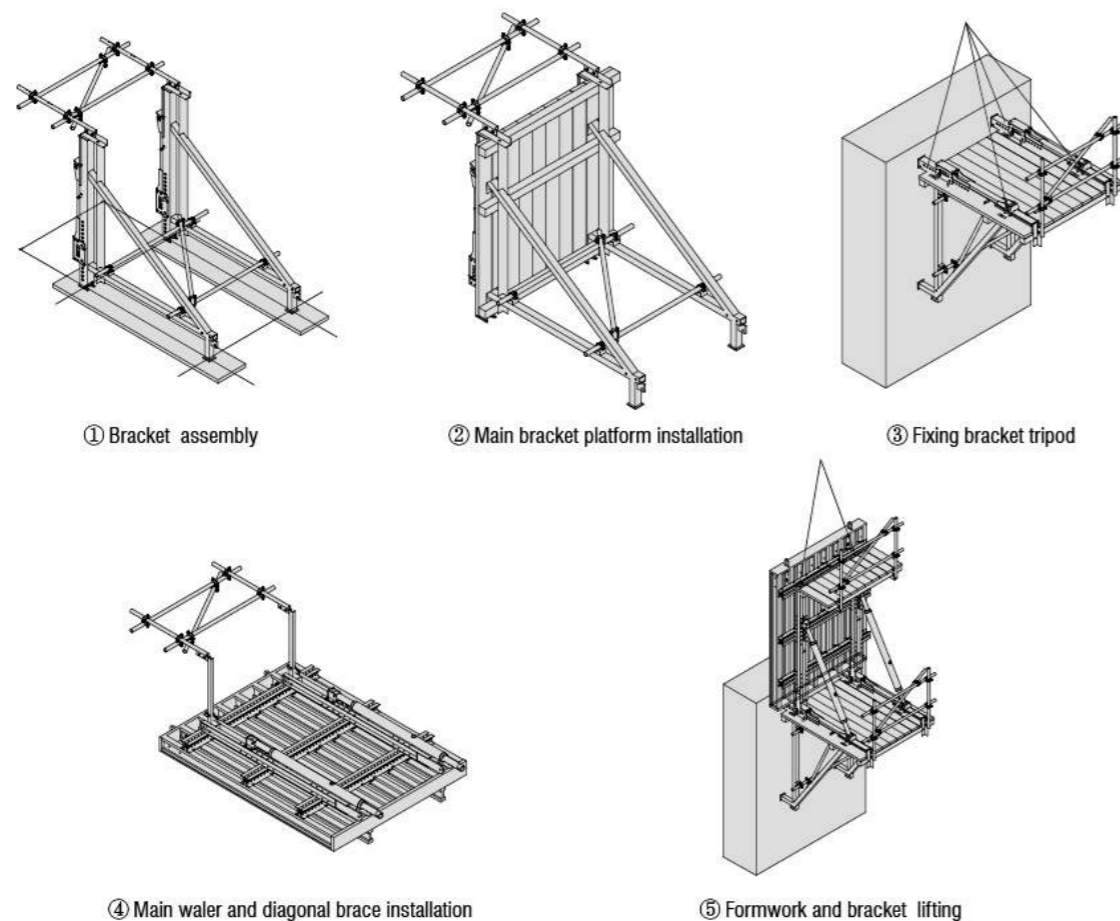

Project application of cantilever climbing formwork



Project name: Monkey Mountain Reservoir
Contractor: China Water Resources and Hydropower, No. 6 Engineering Co., Ltd.
Products utilized: CB-240&CB-180 (Diagonal Brace Type)



Project name: Qingshan Reservoir, Dandong, Liaoning Province
Contractor: China Water Resources and Hydropower, No. 6 Engineering Co., Ltd.
Products utilized: CB-240(Diagonal Brace Type)



Project name: Hutong Yangtze River Bridge Pier
Contractor: China Railway Bridge Group Fourth Engineering Co., Ltd.
Products utilized: CB-240 (Truss Type)



Project name: Wudongde Hydropower Station
Contractor: China Water Resources and Hydropower, No. 6 Engineering Co., Ltd.
Products utilized: CB-240(Diagonal Brace Type)



Project name: Shankou River Bridge
Contractor: CSCEC
Products utilized: CB-240(Diagonal Brace Type)



Project name: Jianyuan Highway, TJ8 Section
Contractor: China Water Resources and Hydropower, No. 6 Engineering Co., Ltd.
Products utilized: CB-240(Diagonal Brace Type)



Project name: Wusi River Bridge
Contractor: Sichuan Highway and Bridge Construction Group Co., Ltd.
Products utilized: CB-240(Diagonal Brace Type)

Protection Screen and Unloading Platform



Introduction

Protection screen is a safety system in the construction of high-rise buildings. The system consists of rails and hydraulic lifting system and is able to climb by itself without crane. Protection screen has the entire pouring area enclosed, covering up three floors at the same time, which can more effectively avoid high air fall accidents and ensure the safety of the construction site. The system can be equipped with unloading platforms.

After pouring the slab, the formwork and scaffolding can be transported to the unloading platform, and then lifted by tower crane to the upper level for next step working, so that it greatly saves manpower and material resources and improves the construction speed. The protection screen is an advanced, state-of-the-art system which suits the demand for safety and civilization on site, and it indeed has been widely used in high-rise tower construction.

Further, the exterior armor plate of the protection screen is a good advertising board for publicity of the contractor.

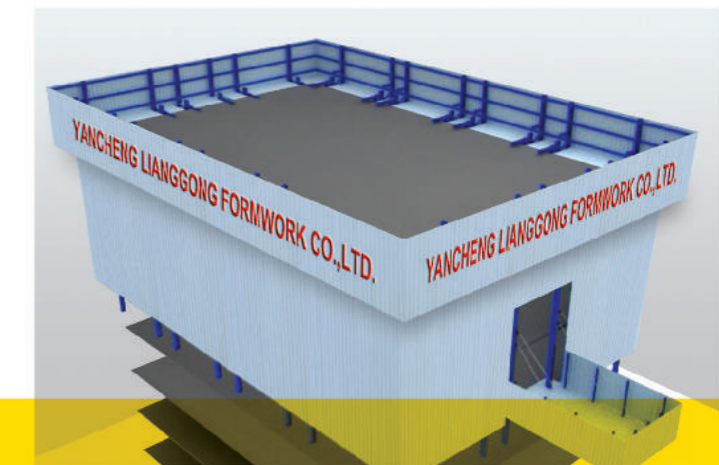

Structure diagram

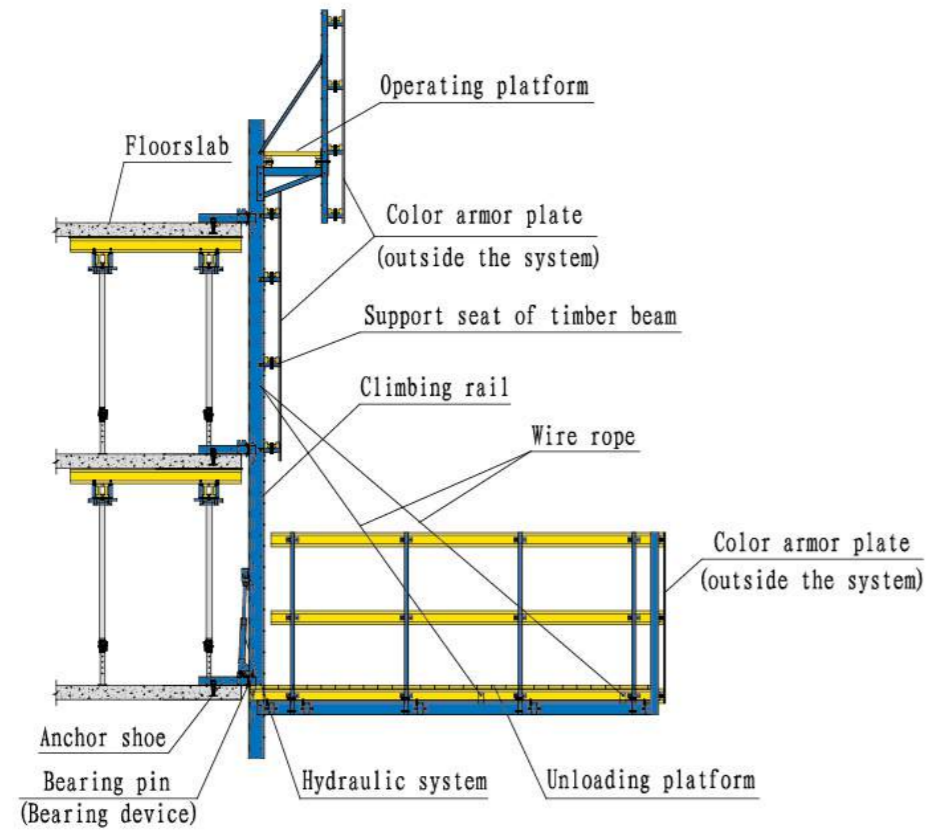

Standard components

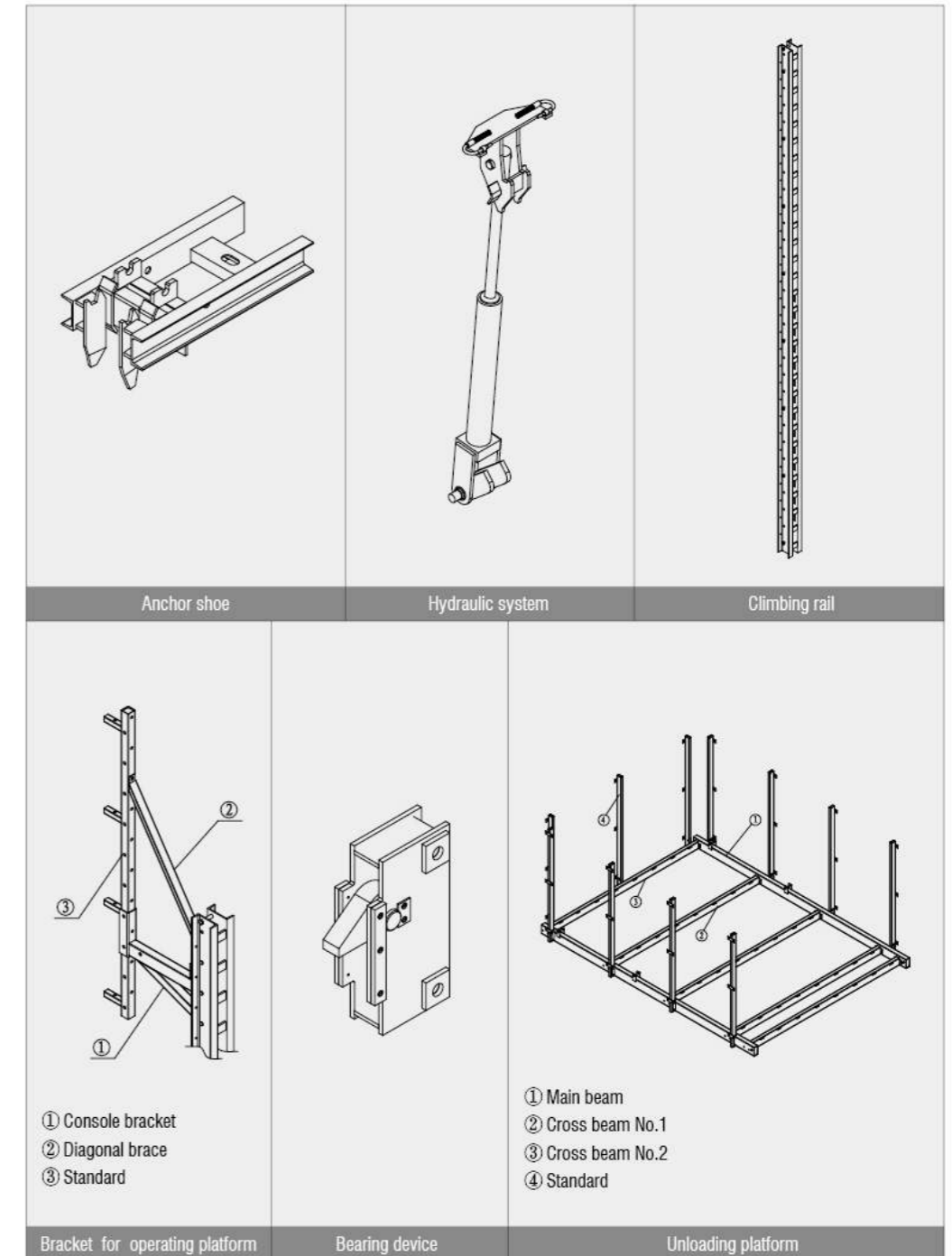

Introduction to auto-climbing protection screen

Anchor system

The anchor and the anchor shoe are the main load bearing parts of the protection screen. The anchor shoe is fixed on the floor by tensile bolt. The anchor system consists of the following components:

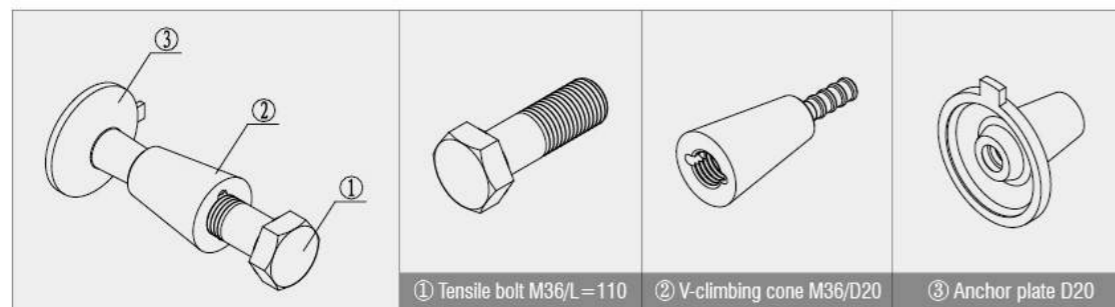

Single-side Bracket

Hydraulic and load bearing system

The power of the protection screen system comes from the hydraulic system, which lifts the climbing rails up gradually, thus enabling the entire protection screen system to climb up 300mm every time. The picture below shows the powering part of the protection screen. Insert the load bearing pin when the rail climbs to the desired position. The load-bearing device is installed in the middle of each rail as a movable load-bearing part.

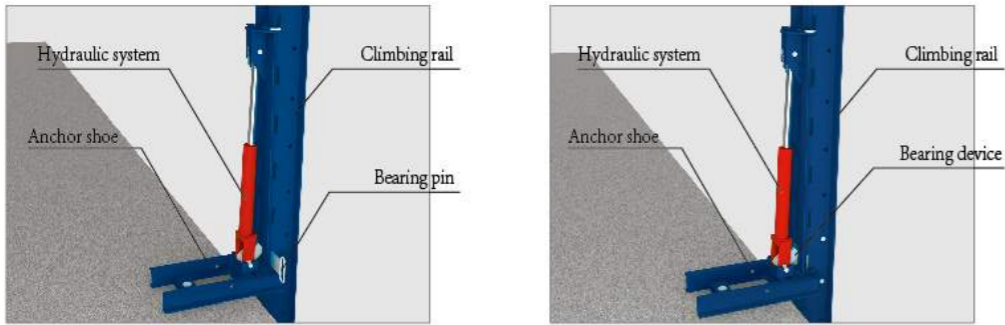

Anchor system installation

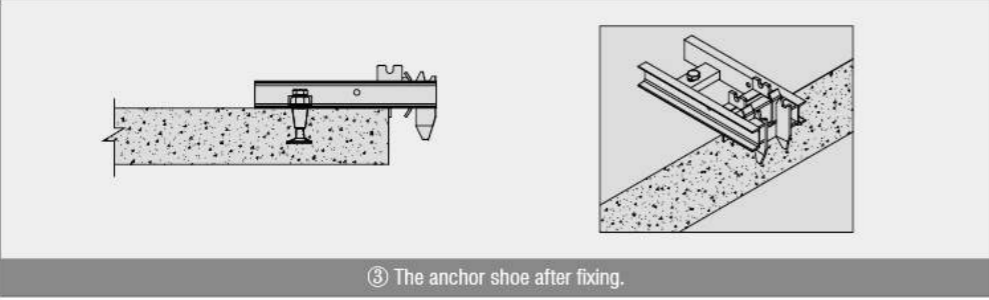
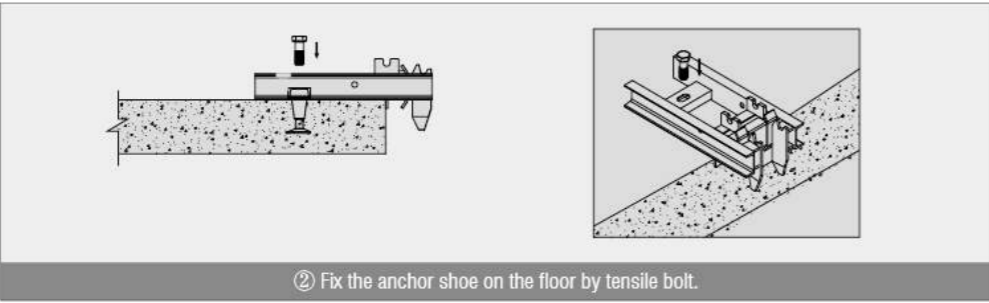
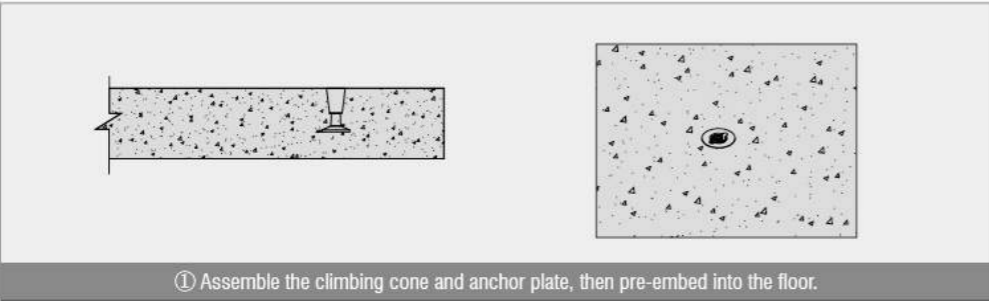

Single-side Bracket

Single-side Bracket

Introduction

Single-side bracket is a formwork system for concrete casting of single-side wall, characterized by its universal components, easy construction and simple and quick operation. Since there is no wall-through tie rod, the wall body after casting is completely water-proof. It has been widely applied to the outer wall of basement, sewage treatment plant, subway and road& bridge side slope protection.

Due to the area limitation of construction sites and the development of slope protection technology, the application of single-side bracket for basement walls is becoming more and more common. As the lateral pressure of concrete cannot be controlled without wall-through tie rods, it has caused too much inconvenience to formwork operation. Many engineering projects have adopted a variety of methods, but formwork deformation or breaking occurs now and then. The single-side bracket manufactured by our company is specially designed to serve the need on site, and it solves the problem of formwork reinforcement. The design of the single-side formwork is reasonable, and it has the advantages of convenient construction, simple operation, fast speed, reasonable load bearing and labor saving, etc. Maximum cast height at one time is 7.5m , and it includes such important parts as single-side bracket, formwork and anchor system.

Two types of single-side bracket:

Structure diagram of truss type

Composite-type single-side bracket is to be formed by standard frame and heighten frames as per project need for different heights, being up to 7.5m in one time casting.

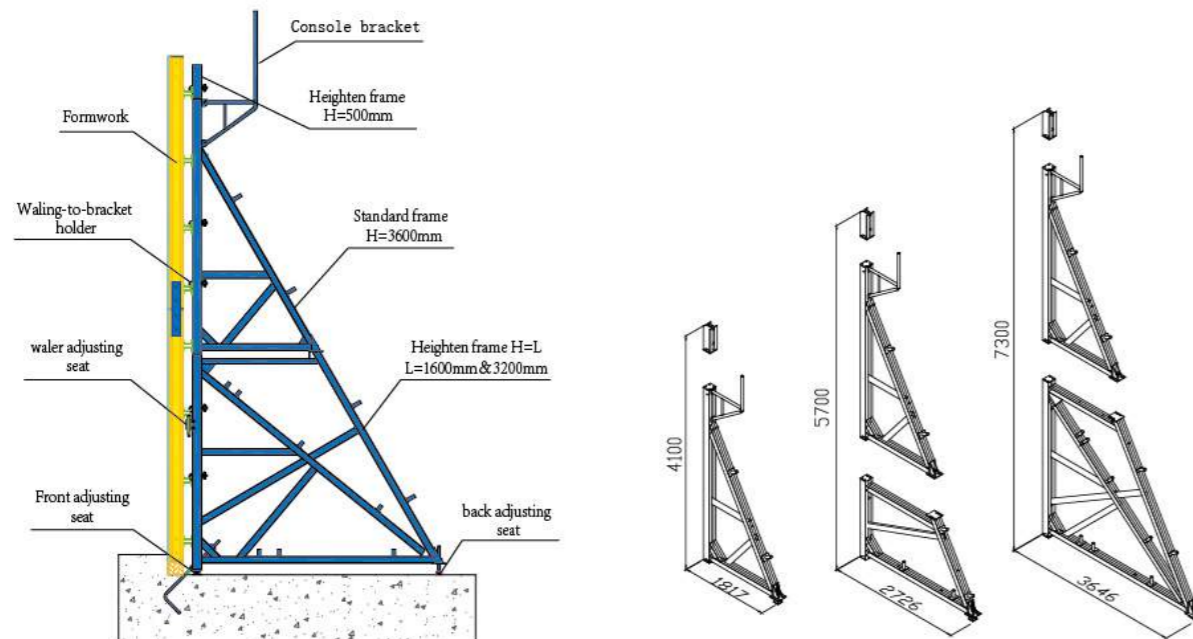

Structure diagram of diagonal brace type

Compared with the composite type, the diagonal-brace-type single-side bracket has the advantages of simple structure, convenient disassembly and assembly, convenient storage and transportation.

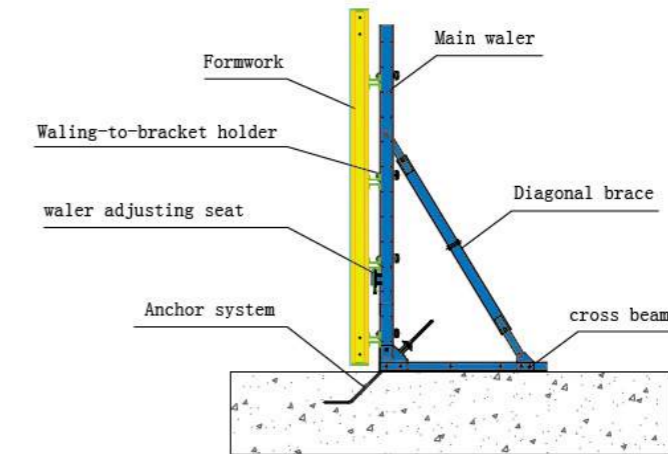

Introduction to single-side bracket

Anchor system

Anchor system is the main load bearing system of the single-side bracket and consists of following five parts.

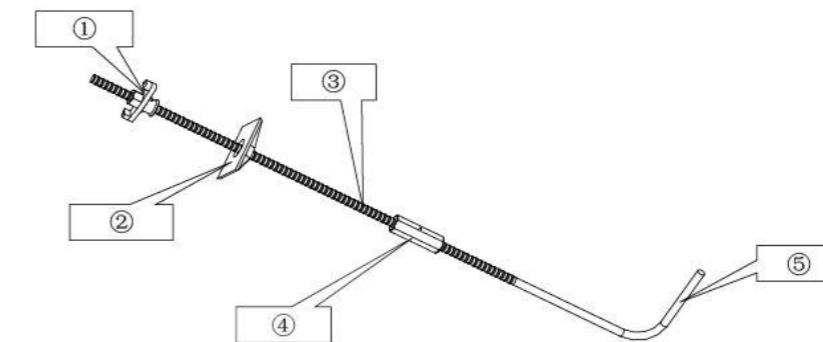

Standard components

Components of truss-type

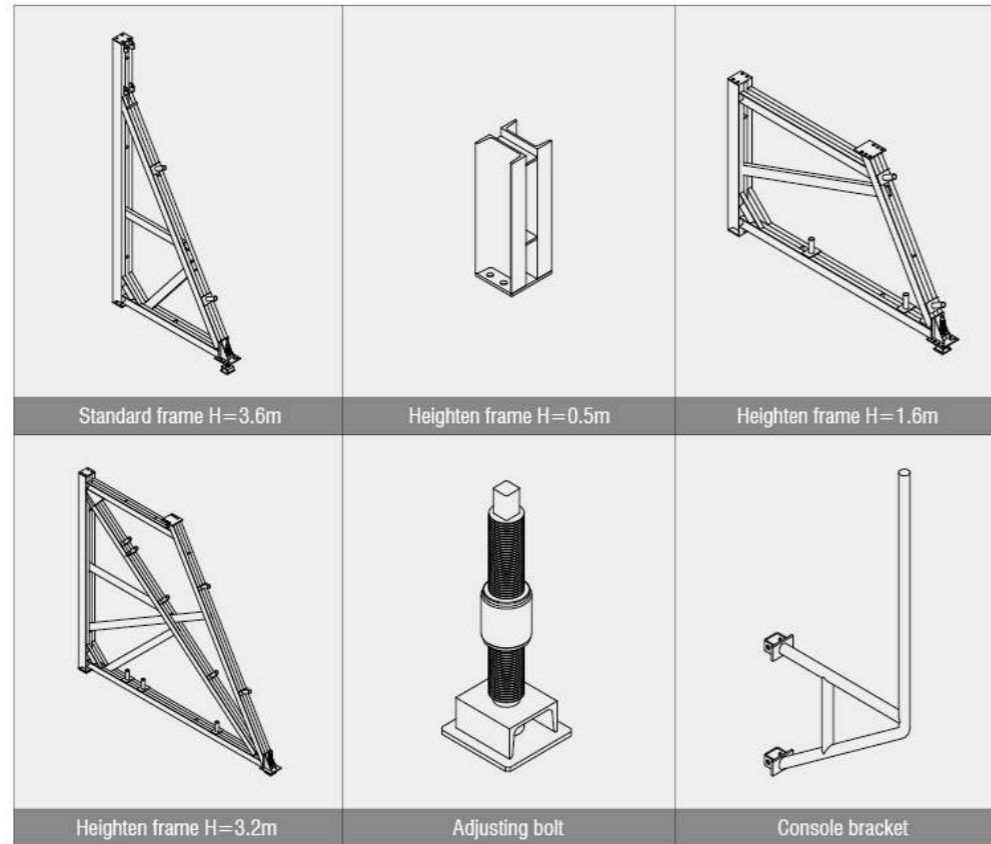

Components of diagonal-brace-type

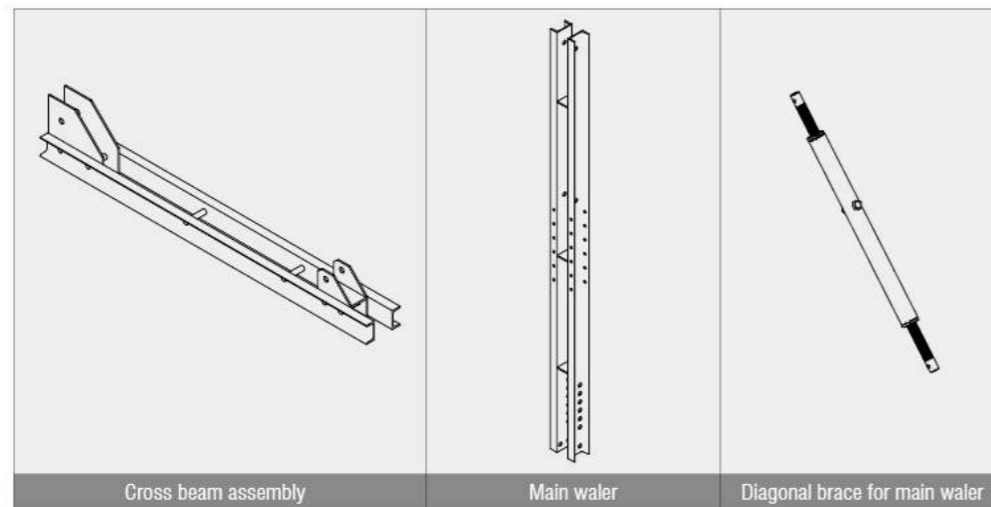

Project application of single-side bracket

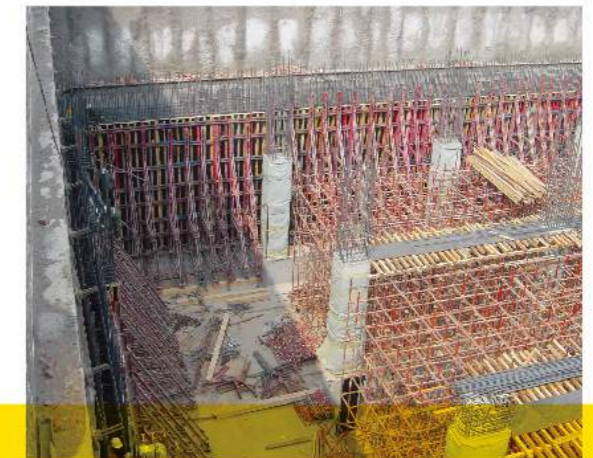
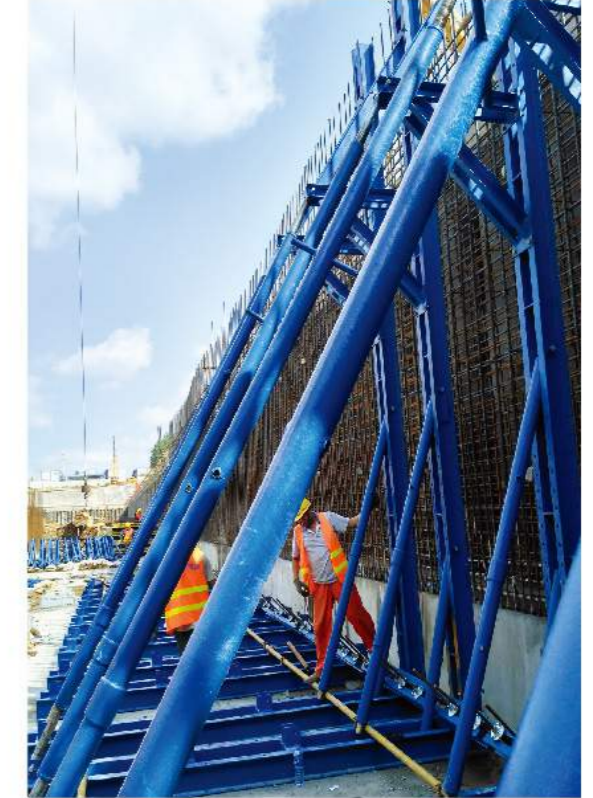

Single-side Bracket

Shaft Beam Platform

Introduction

Shaft platform is mainly used for concrete casting of shaft of high-rise buildings, such as elevator, equipment shaft and stairwell. The lateral pressure of concrete is mainly borne by the wall-through tie rod, and the shaft beam platform has the advantages of being simple, quick and economic in operation.

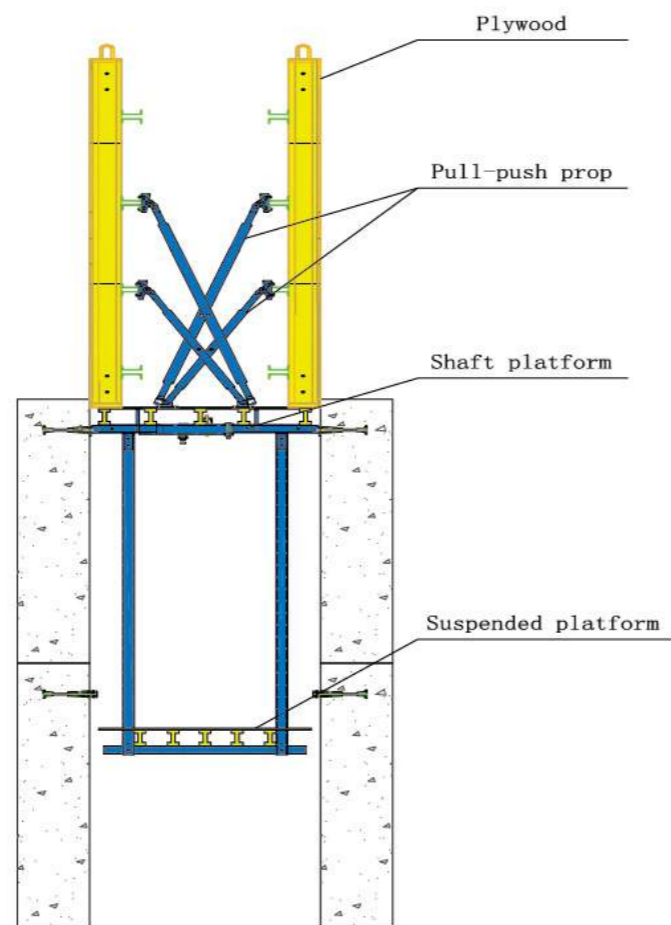

Introduction to the system

Shaft beam platform consists of platform board, timber beam, beam clamp, shaft beam and anchor.

The structure drawing is as follows:

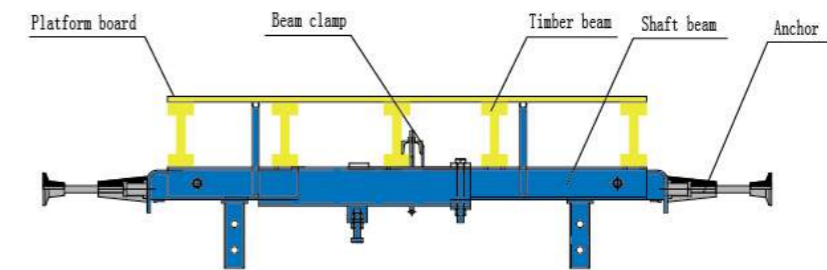

In the drawing, L is the length of timber beam and W is adjustable. Shaft beams are in a few specifications, ranging from 1.45m to 5.8m, to adapt being adapted to widths of different shafts, and selected as per need.

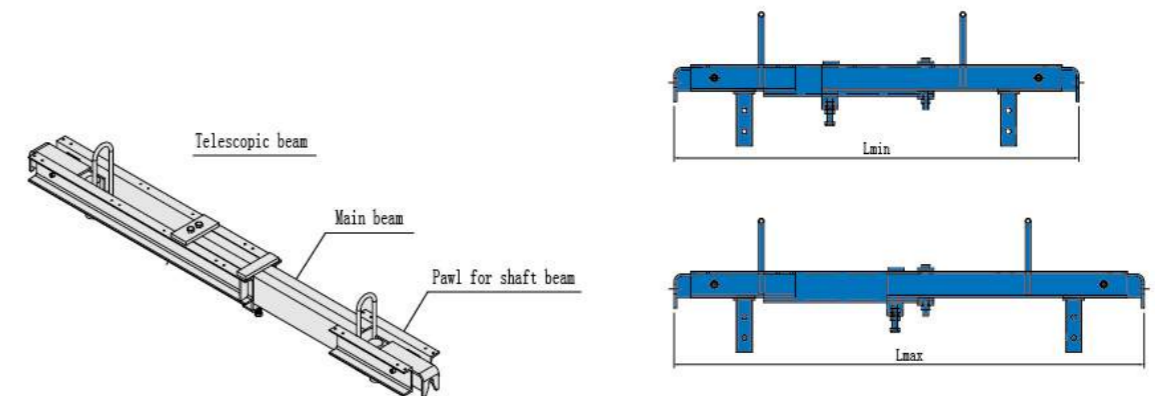
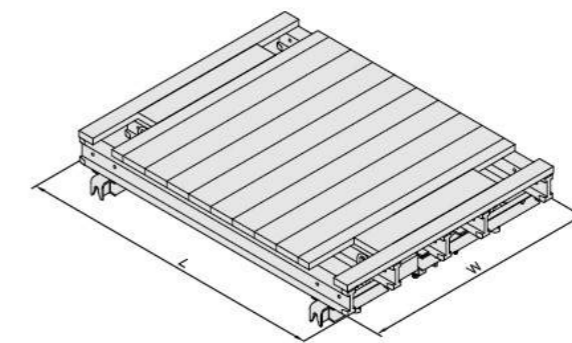



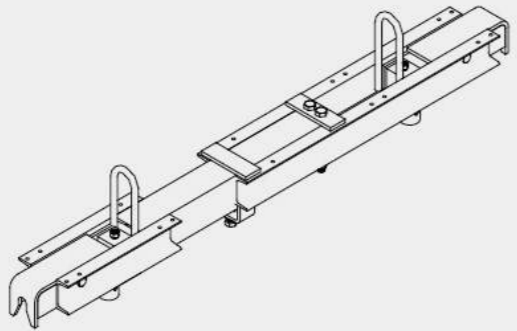
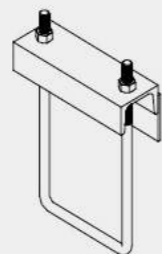
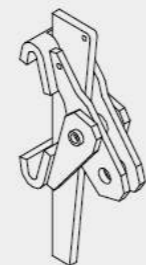

Structure diagram of shaft beam

Length adjustment diagram of shaft beam

Main components

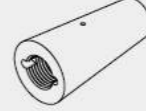
	Model	Weight (kg)
Shaft beam		
	Adjustable range: 1.45m-1.7m	74.54
	Adjustable range: 1.7m-2.1m	88.68
	Adjustable range: 2.1m-2.7m	120.43
	Adjustable range: 2.7m-3.8m	179.19
	Adjustable range: 3.8m-5.9m	301.87
Flange clamp for timber beam		
	Clamp [12]	1.99
	Clamp [14]	2.20
	Clamp [16]	2.34
Connecting shoe for diagonal brace		
	Connecting shoe for diagonal brace [10]	4.28
	Connecting shoe for diagonal brace[12]	4.28
	Connecting shoe for diagonal brace [14]	4.28

	Model	Weight (kg)
Diagonal brace for wall		
	Adjustable range for long rod: 2.35m-3.55m	25.35
	Adjustable range for short rod: 1.22m-1.56m	10.66
Anchor device		
	Tensile bolt M30 L=100	1.04
		
	Climbing cone M30/D20	5.01
		
	Anchor plate D20	1.20
		
	High-strength tie rod D20	0.65

Shaft beam platform lifting

The platform and formwork must be hoisted separately. First, lift the formwork, and then the platform. When the platform is in place, the claw of the shaft beam must be fixed tightly on the tensile bolt.

Diagrams of shaft beam platform lifting

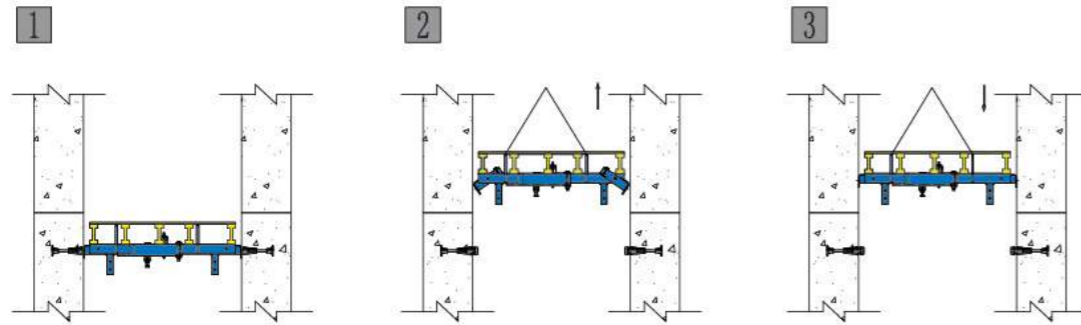

Shaft beam platform lifting

The Shaft beam platform should be used with other formwork system in construction process. The picture on the below is the diagram of collaboration of shaft beam platform and cantilever formwork CB-240.

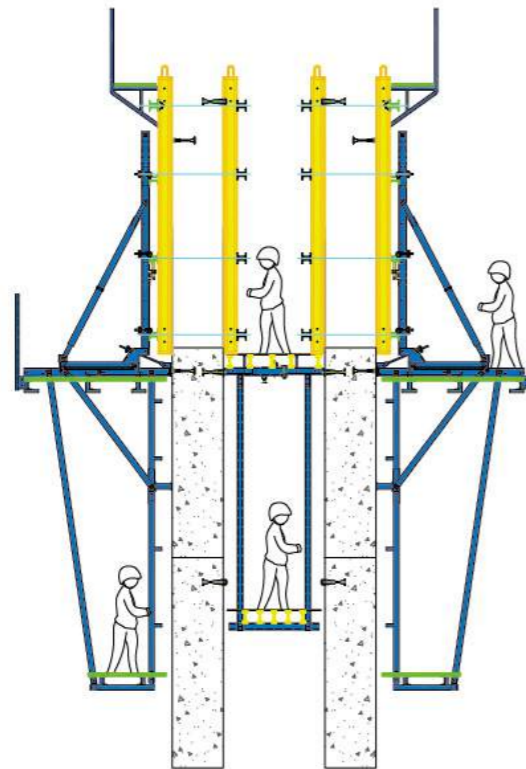

Project application of shaft beam platform



Table Formwork

Flexible and fast slab formwork



Introduction

Table formwork is a kind of formwork that used for floor pouring , used widely in high-rise building , multi-level factory building , underground structure etc. During the construction, after the pouring completion, table formwork sets can be lifted by lifting fork to an upper level and reused, without need to dismantle. Compared with the traditional formwork, it is featured by its simple structure, easy disassembly, and being reusable. It has eliminated the traditional way of slab support system, which consists of cuplocks, steel pipes and timber planks. The construction speeds up obviously, and manpower has been saved greatly.

Standard unit of table formwork

Table formwork standard unit has two sizes: 2.44 × 4.88m and 3.3 × 5m .The structure diagram is as follows:

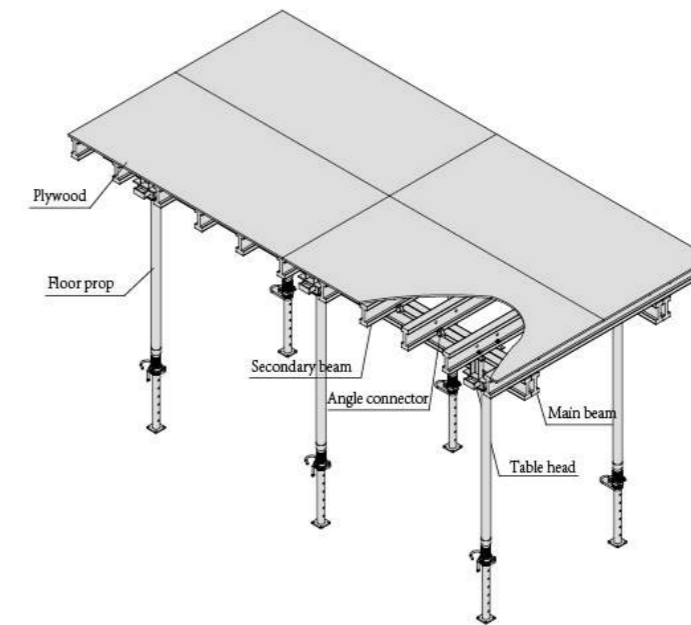

Assembly diagram of standard table formwork

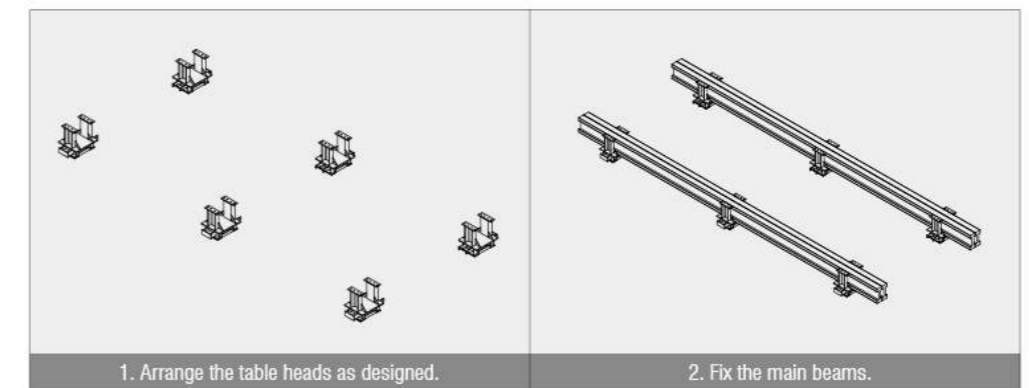

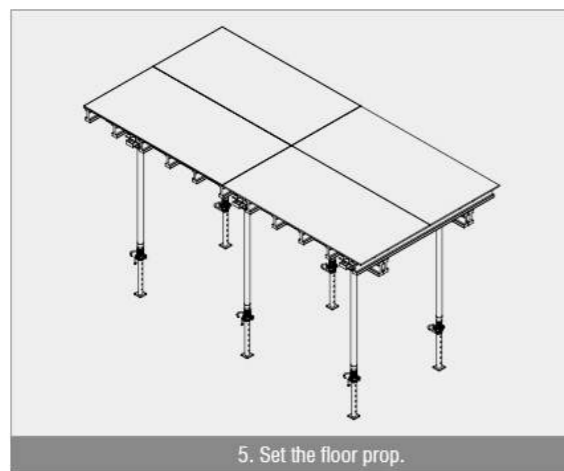
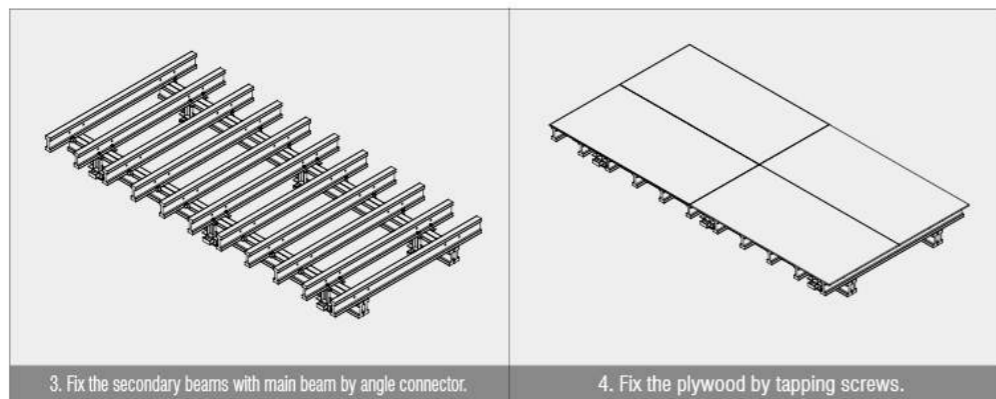

Table head in use



Angle connector in use

For untypical floor casting, the non-standard table formwork can be designed according to the need. The combination of non-standard and standard table formwork can meet the needs of various shapes of floor pouring.

Edge and middle filler

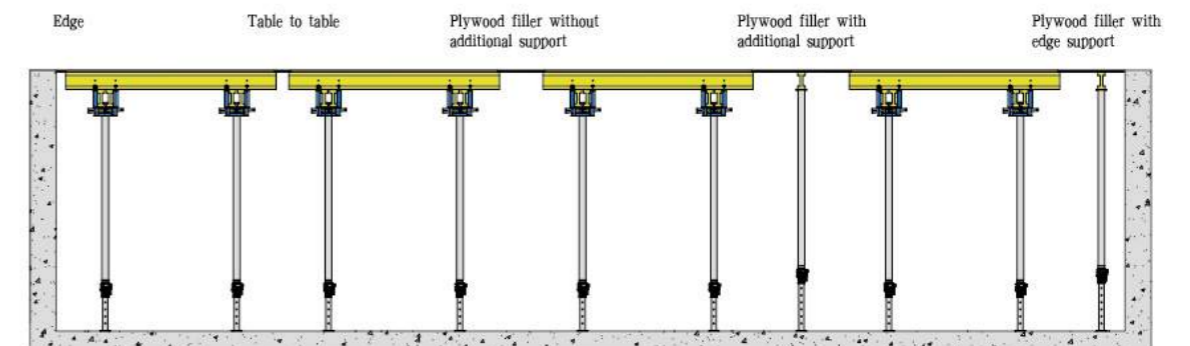
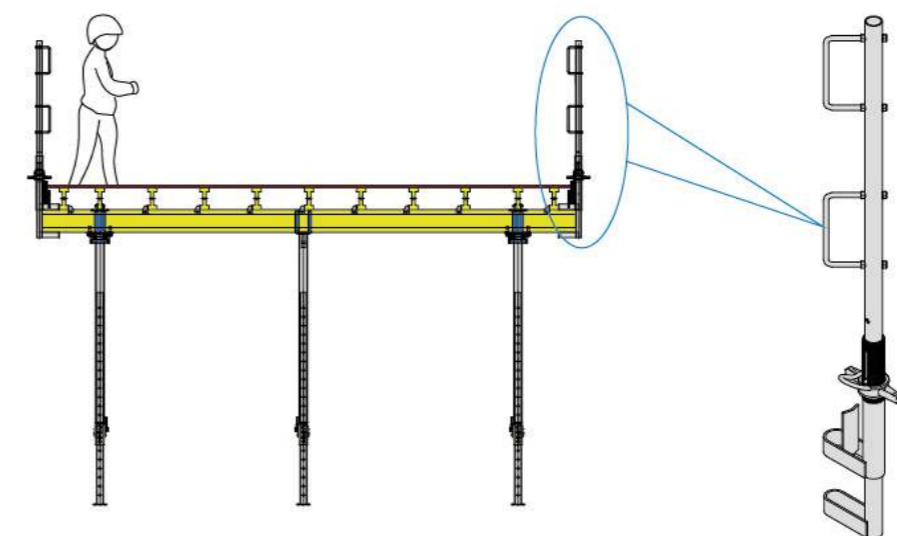

Table formwork guardrail

The guardrail can be set at the edge of floor as needed, shown in the figure:



Lifting fork

The lifting fork for table formwork is used for lifting of the table formwork unit, which allows the overall transportation of the large-area table formwork, greatly improving the work efficiency and saving time. There are currently two main types of lifting forks as shown:

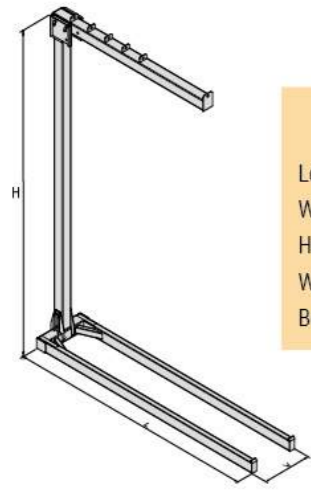

Length: 500cm
Width: 98cm
Height: 646cm
Weight: 803.68Kg
Bearing load: 1T

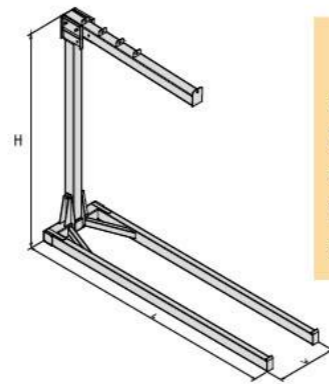

Length: 520cm
Width: 106cm
Height: 425cm
Weight: 821.9Kg
Bearing load: 1.5T

Lifting fork operation chart

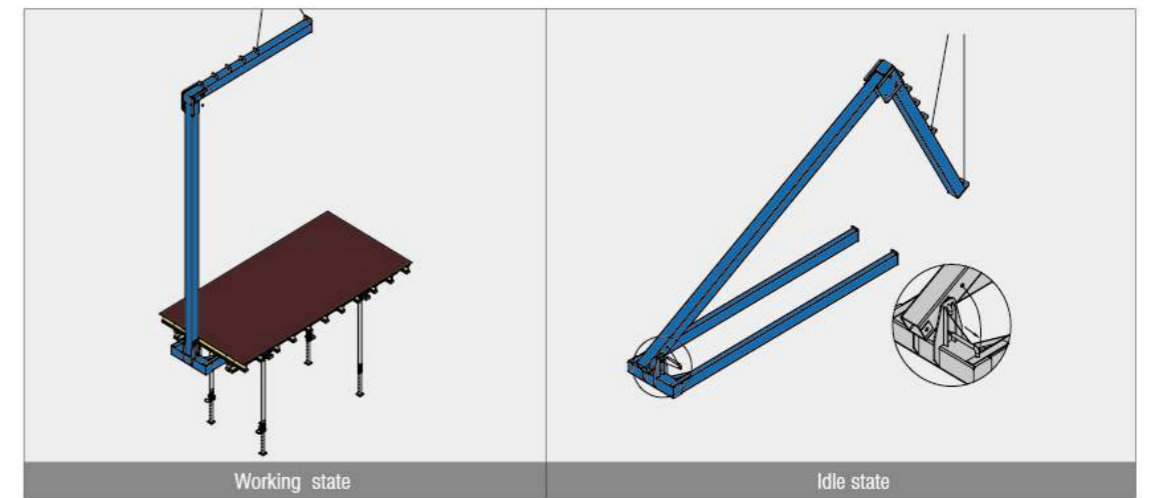
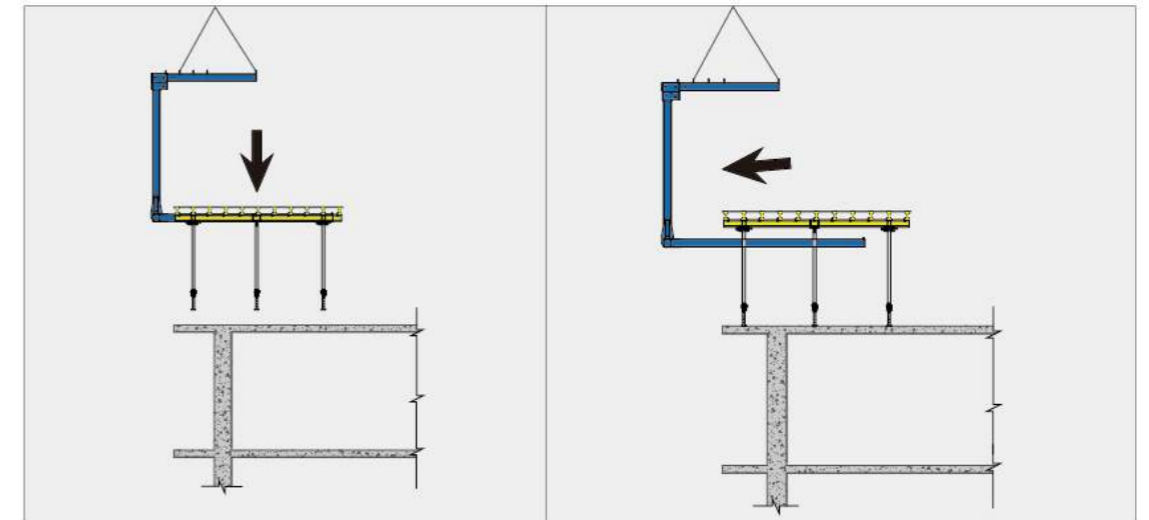
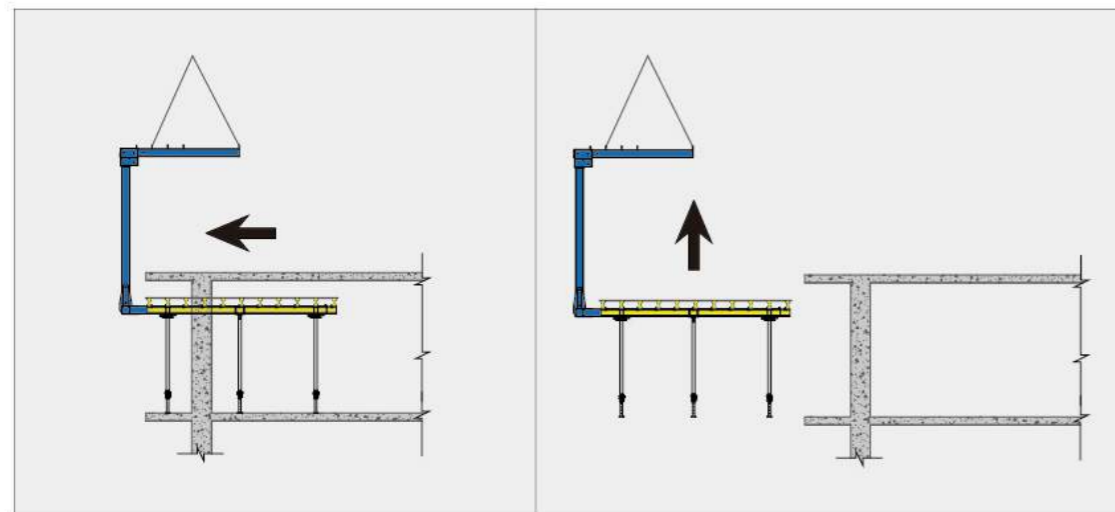

Project application of lifting fork



Shifting Trolley

The shifting trolley is used for the overall transportation of the formwork in the horizontal direction.

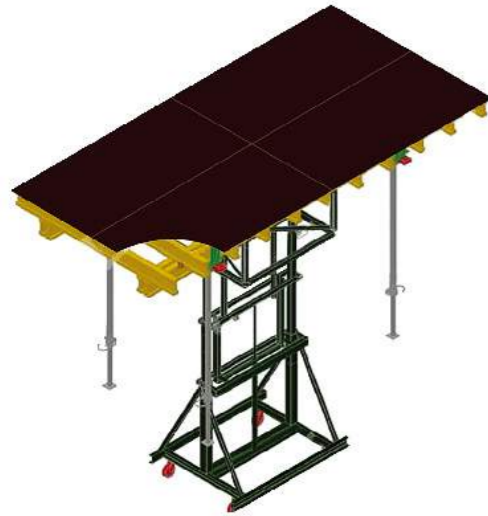

Trolley application diagram

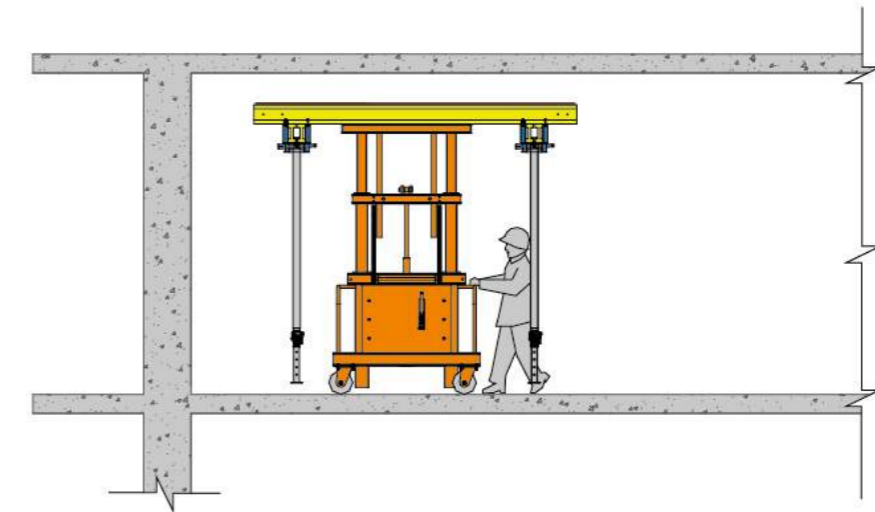

Standard components

Standard device
Weight: 516.31Kg
Item No.: 02030700

Standard device with attached frame

Attached frame
standard device



Attached frame
Weight: 72.17Kg
Item No.: 02030701



Height:
Standard device
H_{min} = 1750mm H_{max} = 3250mm
Standard device with an attached frame
H_{min} = 2500mm H_{max} = 3900mm

Bearing load
Standard device: 15~20KN
Standard device with an attached frame: 11kN.

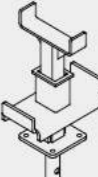
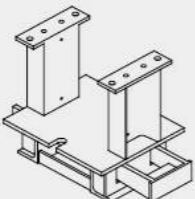
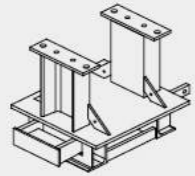
No.	Name & Sketch	Weight(Kg)	Spec.	Remarks
02080100A	Lowering head 	3.45	L=328	For supporting timber beam.
02080200A	U-head 	1.50	L=178	For supporting timber beam.
02080301 02080401	Straight angleJack 	3.28 3.05	Φ61 L=160mm Φ50 L=160mm	For supporting timber beam.

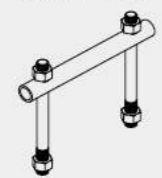
Standard components

No.	Name & Sketch	Weight(Kg)	Spec.	Remarks
02080302 02080402	Quick striking ring 	2.28 2.09	Φ61 L=160mm Φ50 L=160mm	Used together with straight angle jack, for taking down beams quickly.
02050500A	Early stripping head 	7.49	L=460mm	For taking down beams quickly.
02030201A	Tabel head I 	19.97		For double main beam
02030101A	Tabel head II 	16.73		For single main beam
02030102	Angle connector 	0.09	2x67x90mm	For connect the beam
02030103	Timber beam washer 	0.01	2x31x25mm	For connecting second beam
02030104	Connection unit 	1.13	M12	For connecting main beam

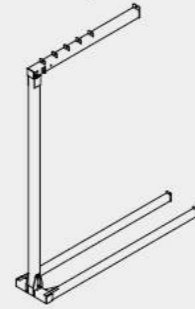
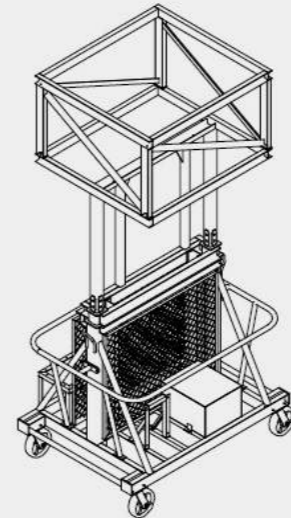
No.	Name & Sketch	Weight(Kg)	Spec.	Remarks
02030202	T-type bolt 	0.33	M20	For connecting main beam
02030500	Handrail 	14.53		For safe construction
02030300	Lifting fork 	803.68		For lifting table formwork
02030600	Trolley 	707.04		For shifting table formwork

Project application of table formwork



Flex-table Formwork System

Introduction

Flex-table formwork system is a formwork for slab concrete pouring in complex floor plan, narrow space. It is supported by steel props or tripods with different support heads, with H20 timber beam as the primary and secondary beams, which are covered with panels. The system can be used for a clear height up to 5.90m.

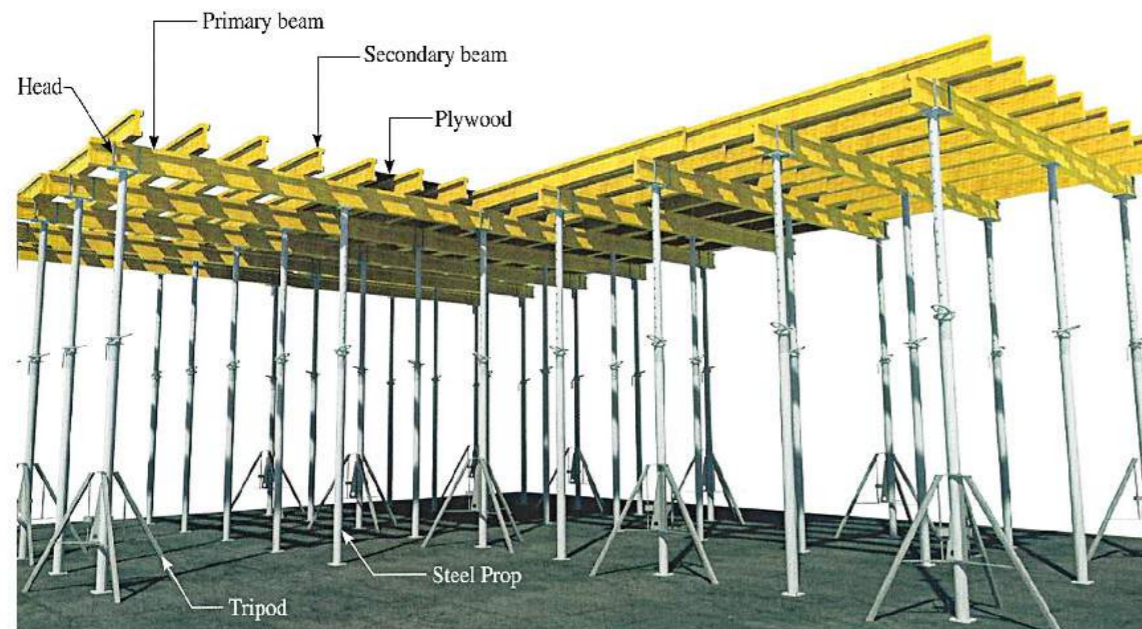

Characteristics

- ◆ The most easy and flex-table formwork system for all types of slabs, consisting of steel props, tripod, four-way head, H20 timber beam and plywood.
- ◆ It is mainly used for decking areas around lift shafts and stair cases, also for villa projects or manual handled slab formwork system with limited crane capacity.
- ◆ This system is fully crane independent.
- ◆ The H20 timber beams due to its easy handling, low weight and excellent statically figures its high-grade bonding and protected beam ends with a plastic bumper assures a long duration of life.
- ◆ This system is simple structure, convenient disassembly and assembly, flexible arrangement and reusability.

Ring-lock Scaffolding and Stair Tower

Ring-lock scaffolding



Introduction

Ringlock scaffolding is a modular scaffold system which is more safe and convenient it can be divided into 48mm system and 60 system. Ringlock system is constitute of standard, ledger, diagonal brace, jack base, u head and other componets. Standard is welded by rosette with eight hole that four small holes to connect ledger and another four big holes to connect diagonal brace.

The reasonable design make the system forced by three points that can resist bending and anti-skating .please refer to the fore diagram below.

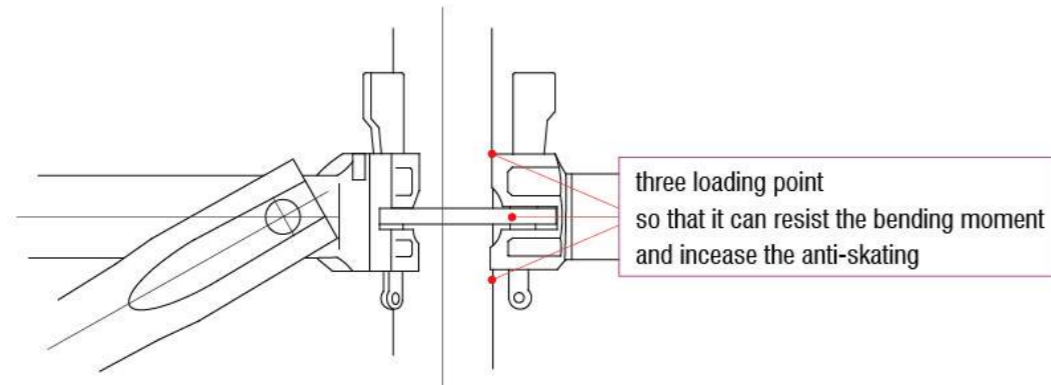

When we hammer down and fix the wedge pin, the joint will be connect with standard closely and make the vibration from ledger pass down to the ground. So it can make the wedge pin get the vibration less and will not be bounced off .

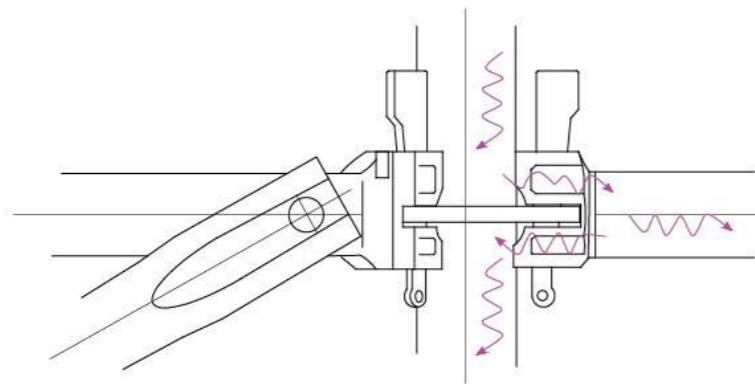

Advantage

- 1 Advanced technology, reasonable joint design ,stable connection.
- 2 Assembling easily and quickly , greatly reduce the time and labor cost.
- 3 Upgrade raw materials by low-alloy steel .
- 4 High zinc coating and long life to use, clean and beautiful.
- 5 Automatic welding ,high precision and superior quality.
- 6 Stable structure ,high bearing capacity, safe and durable.

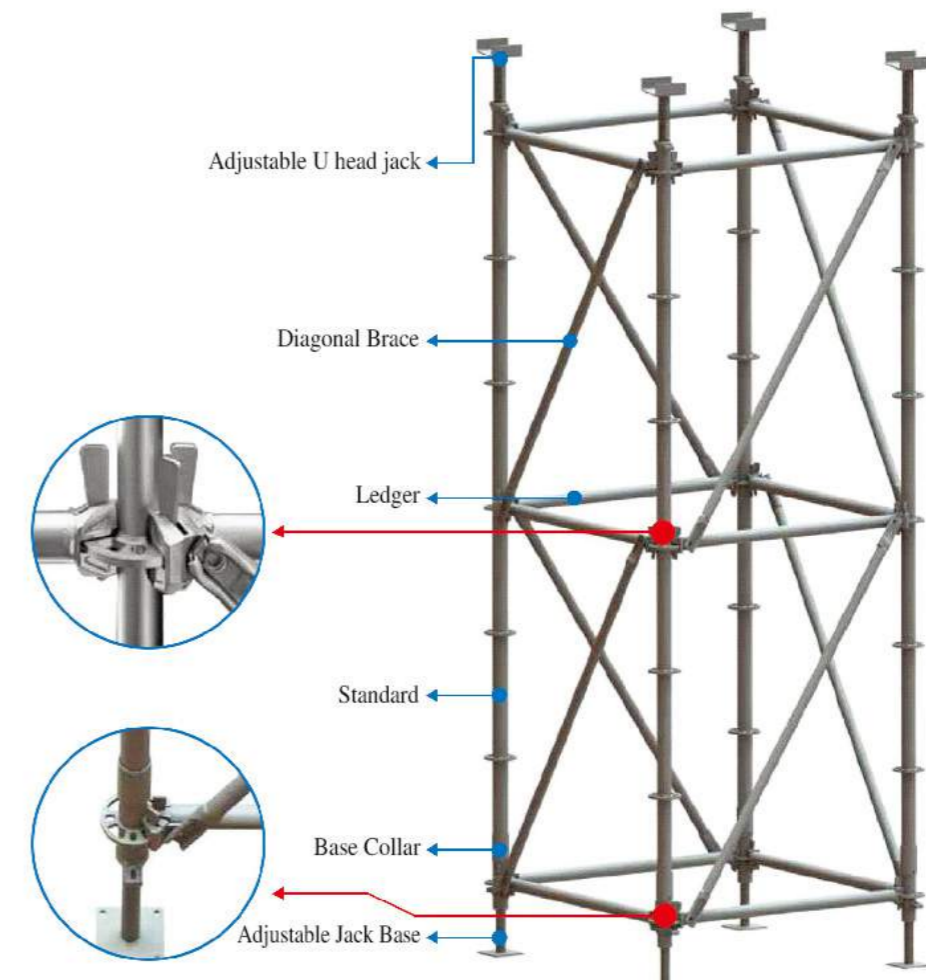

Ringlock system assembly

Adjustable jack base

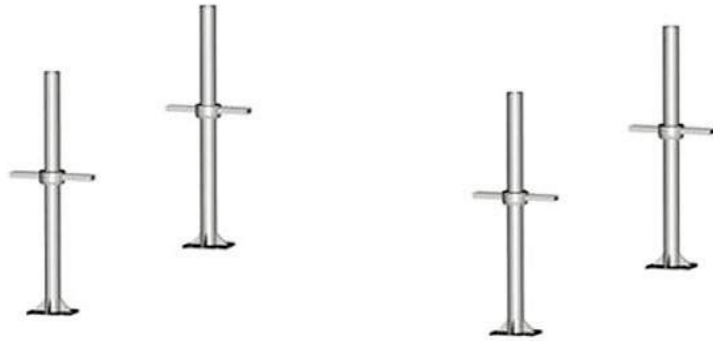

Base collar

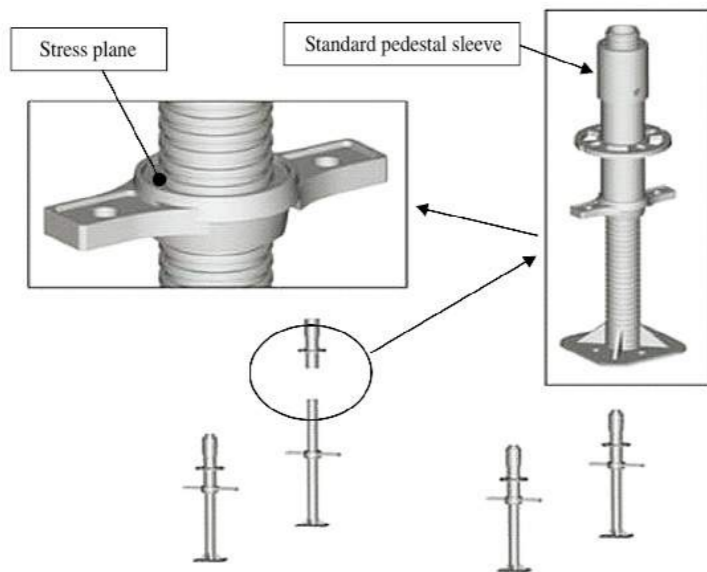

Ledger (first storey)

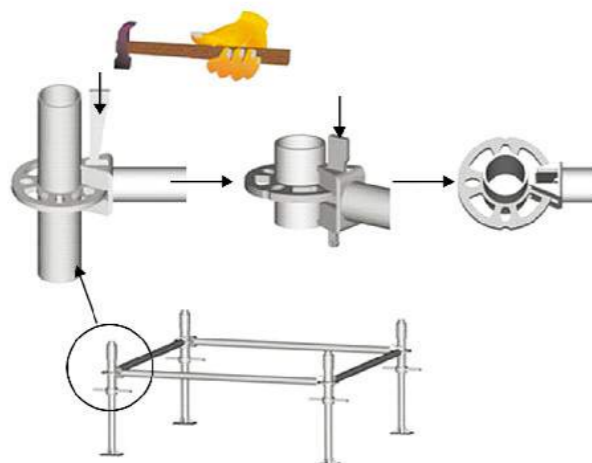

standard(without spigot)

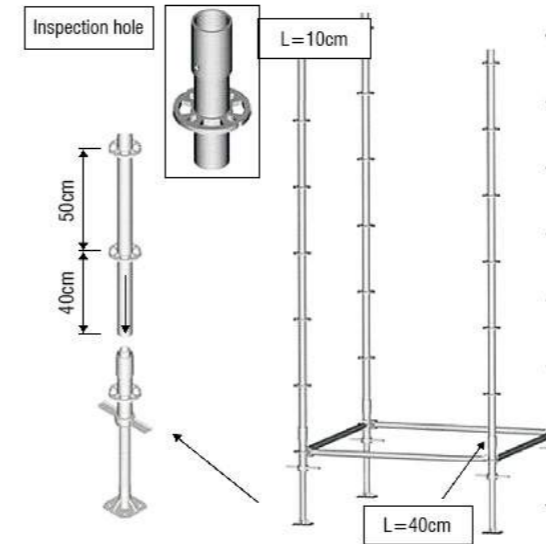

Ledger(second storey)

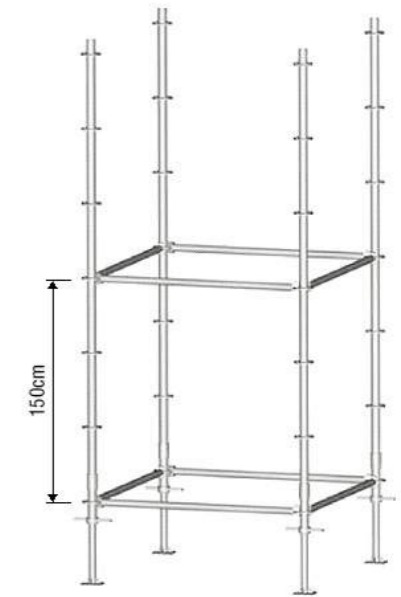

Diagonal brace(first storey)

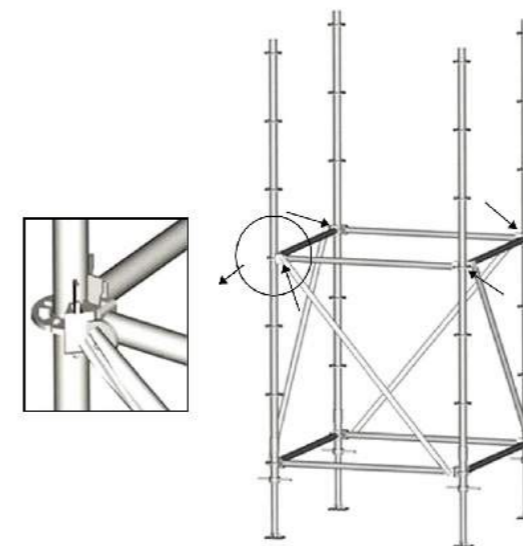

Standard(with spigot)

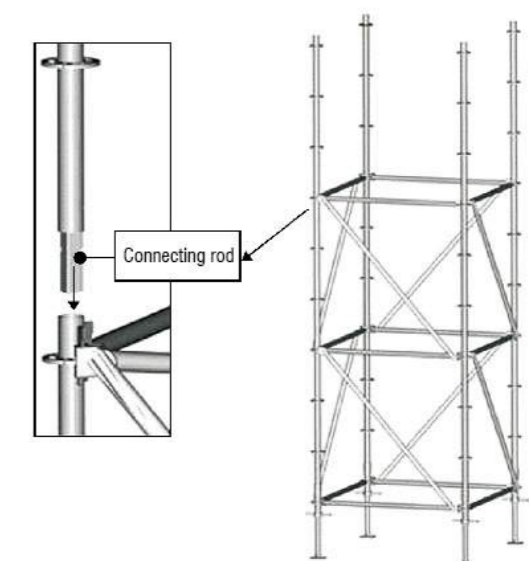

Ledger(third storey)

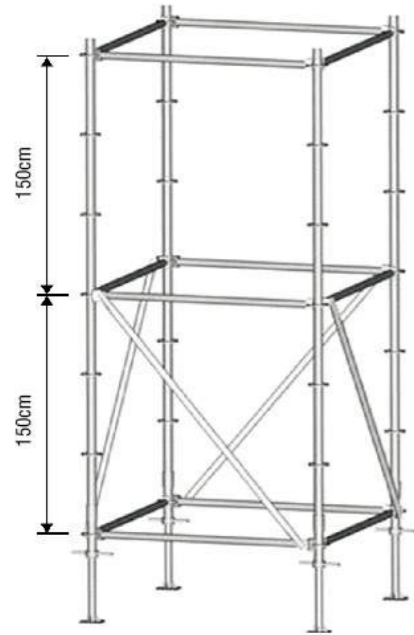

Diagonal brace(second storey)

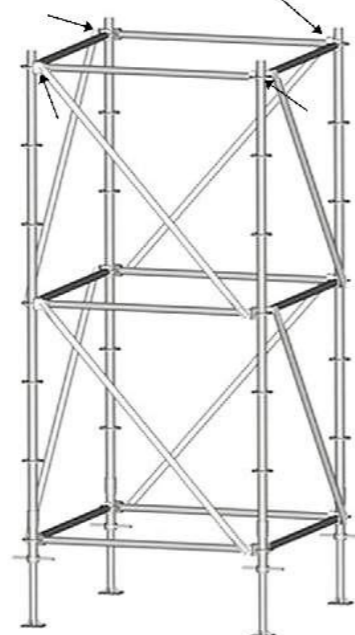

Adjustable U head jack

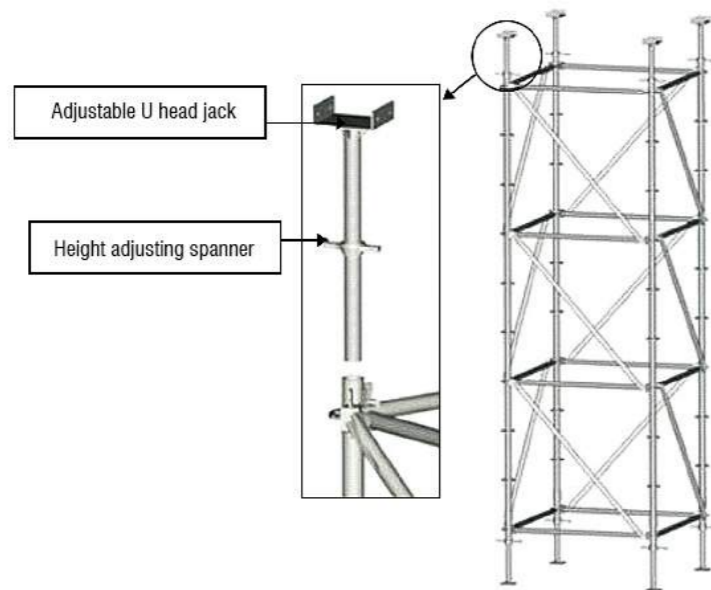

Main components

Item	Length(mm)	Size(mm)	Size(mm)
Standard with spigot Q345	L=1000	φ 48.3*3.25	φ 60*3.25
	L=1500	φ 48.3*3.25	φ 60*3.25
	L=2000	φ 48.3*3.25	φ 60*3.25
	L=2500	φ 48.3*3.25	φ 60*3.25

Item	Length(mm)	Size(mm)	Size(mm)
Ledger (Q235 / Q345)	L=600	φ 48.3*3.25	φ 48.3*2.5
	L=700	φ 48.3*3.25	φ 48.3*2.5
	L=900	φ 48.3*3.25	φ 48.3*2.5
	L=1200	φ 48.3*3.25	φ 48.3*2.5
	L=1500	φ 48.3*3.25	φ 48.3*2.5
	L=1800	φ 48.3*3.25	φ 48.3*2.5
	L=2000	φ 48.3*3.25	φ 48.3*2.5
	L=2500	φ 48.3*3.25	φ 48.3*2.5

Item	Length(mm)	Size(mm)	Size(mm)
Diagonal brace Q345 / Q235	L=1500*900	φ 48.3*2.5	φ 42*2.5
	L=1200*1200	φ 48.3*2.5	φ 42*2.5
	L=1200*1500	φ 48.3*2.5	φ 42*2.5
	L=1500*1500	φ 48.3*2.5	φ 42*2.5
	L=1800*1500	φ 48.3*2.5	φ 42*2.5
	L=2400*1500	φ 48.3*2.5	φ 42*2.5

Item	Length(mm)	Size(mm)	Size(mm)
Base collar Q345	L=300	φ 59*4*100	φ 70*4*110
		φ 48.3*3.2*200	φ 60*3.2*200

Item	Length(mm)	Size(mm)	Size(mm)
Screw Jack Foot	L=600 140*140*6mm	φ 38.5	φ 48.5

	Item	Length(mm)	Size(mm)	Size(mm)
	Screw Jack Head	L=600 180*150*50*6mm	φ 38.5	φ 48.5

Ring-lock stair tower

Introduction

The structure of the ring-lock stair tower is the same as that of the φ60 ring-lock scaffolding, and the cross-section dimension of the stair tower is 1.5×3.0 m. The stair tower is safe and convenient quick to assemble and disassemble, and the force is reasonable.



Project application of ring-lock scaffolding



Bearing capacity of the stair tower

As the height of the tower erection increases, the force it bears decreases. When it is set to 150m, it can still withstand the force of $0.25\text{KN/m} \times 150\text{m} = 37.5\text{KN}$, so it is safe to work when it is 150m high (the tower must be attached to the wall every 4.5m).

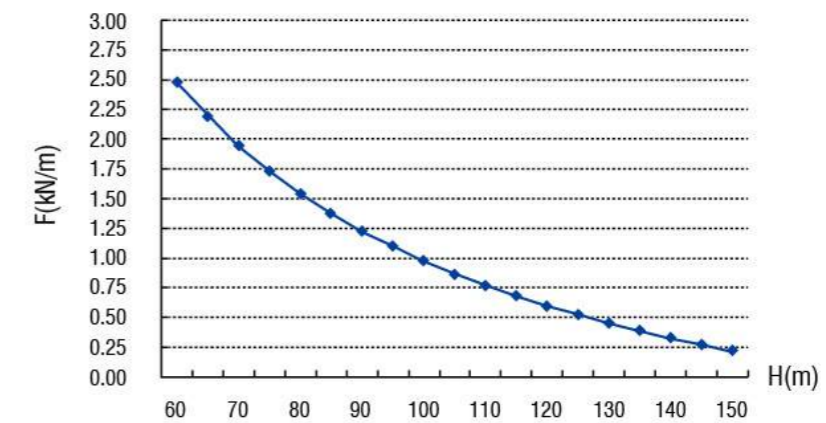

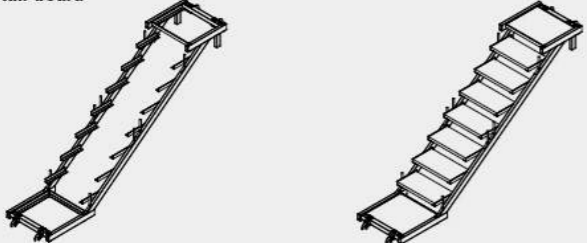
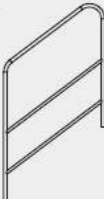
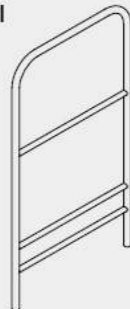
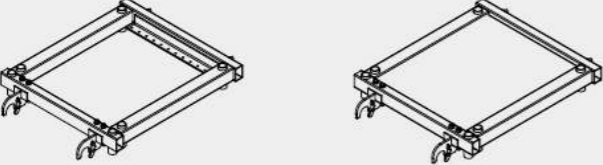
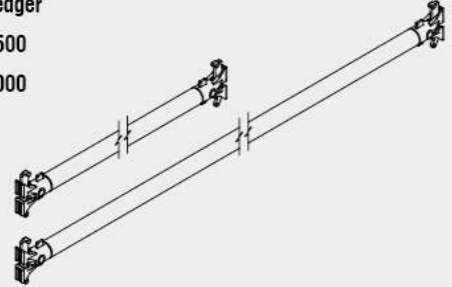

Relationship between force and height

Standard components

	Weight (Kg)	Item No.
Stair board 	67.37 40.0	03130100
Handrail 	4.78	03130200
Guardrail 	4.45	03130300
Top platform board 	15.39	03130400
Ledger 1500 3000 	5.0	

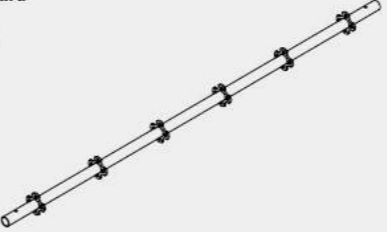
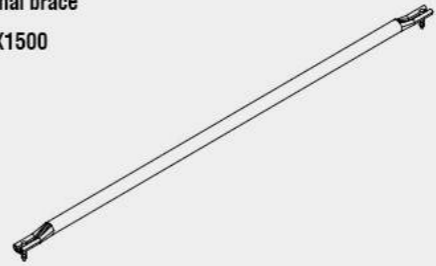
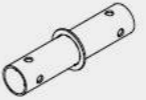
Standard components

	Weight (Kg)	Item No.
Standard 3000 	15.83	03120205
Diagonal brace 1500X1500 	7.17	03120302
Standard connector 	0.87	03120400
Connecting pin 	0.30	03120500
Screw jack foot 	5.32	03061000

Project application of ring-lock stair tower



Steel Prop and Tripod

Steel prop

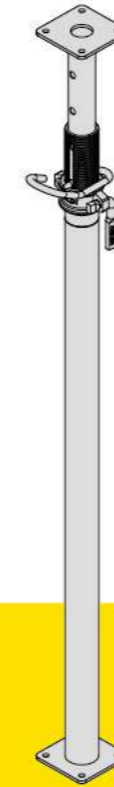

The steel prop is a support device widely used for supporting the vertical direction structure, that adapt to the vertical support of the slab formwork of any shape. It is simple and flexible, and the installation is convenient, being economical and practical. The steel prop takes small space and is easy to store and transport.

Steel prop is adjustable within a specific range and can be adjusted as needed.

There are mainly three types of steel props :

1. Outer tube ϕ 60, Inner tube ϕ 48 (60/48)
2. Outer tube ϕ 75, Inner tube ϕ 60 (75/60)
3. Outer tube ϕ 88.5, Inner tube ϕ 75.5 (88.5/75.5)

Finished steel prop



Steel prop in use



Standard specifications

Specification	Weight (Kg)	Item No.
75/60 Series Bearing capacity:30KN, Galvanized.		
250A (75/60) Height:1400~2500	14.64	II 03020100
300A (75/60) Height: 1650~3000	16.53	II 03020200
350A (75/60) Height: 1900~3500	19.93	II 03020300
400A (75/60) Height: 2150~4000	25.32	II 03020400
550B (88.5/75.5), Bearing capacity:20KN, Galvanized. Height: 2900~5500	31.65	II 03020500

Standard specifications

Specification	Weight (Kg)	Item No.
60/48 Series Bearing capacity:20KN, Galvanized.		
250B (60/48) Height: 1400~2500	11.5	II 03020600
300B (60/48) Height: 1650~3000	13.98	II 03020700
350B (60/48) Height: 1900~3500	17.79	II 03020800

Foldable tripod

Tripod is used for reinforcement of steel prop. It is foldable, being convenient for transport and storage.

There are two specifications for the tripod: H70 and H90 .

H70 is for reinforcing steel prop with outer pipe of $\phi 60$.
H90 is for reinforcing steel prop with outer pipe of $\phi 75$.

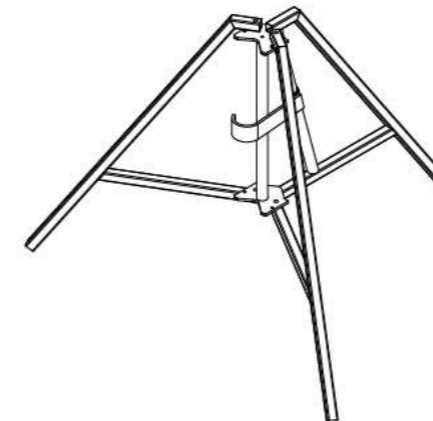

Scaffolding Tower

Introduction

The scaffolding tower using steel pipe support frame is a new type of support system in modern construction. The product is quick to assemble and disassemble, with strong stability and high bearing capacity, and it is widely used in industrial and civil buildings, bridges, tunnels and dam projects. At present, our company produces three main types of towers.

First : $\phi 48$ square tower

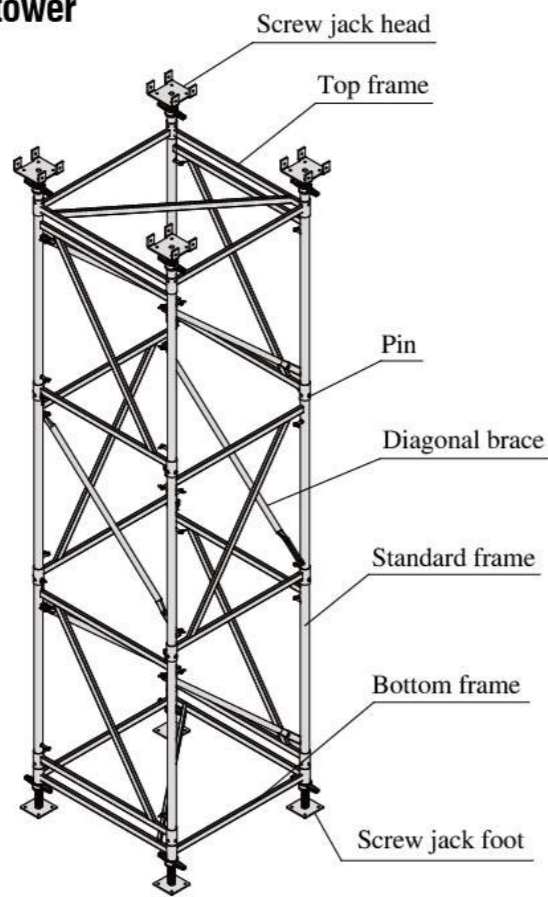

The bearing capacity of square tower (take H=1.2m standard frame as an example)

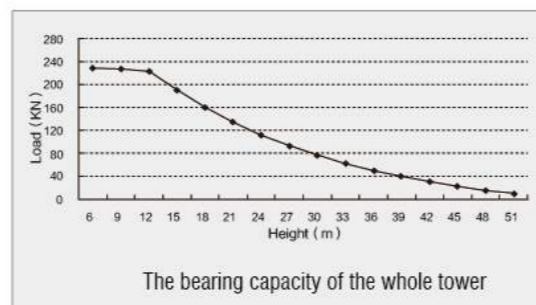
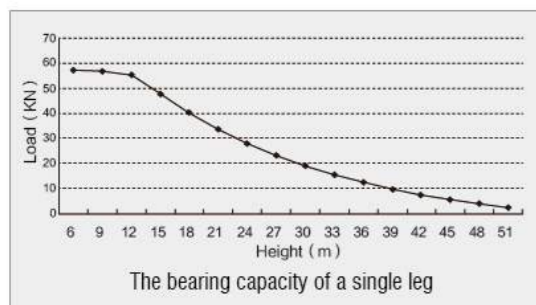

Second: triangular tower

The standard components of this type of tower are triangular and have three cross-section dimensions, 1.0 x 1.5 m, 1.0 m x 1.0 m, 1.5 m x 1.5 m. The standard is $\phi 48$ mm.

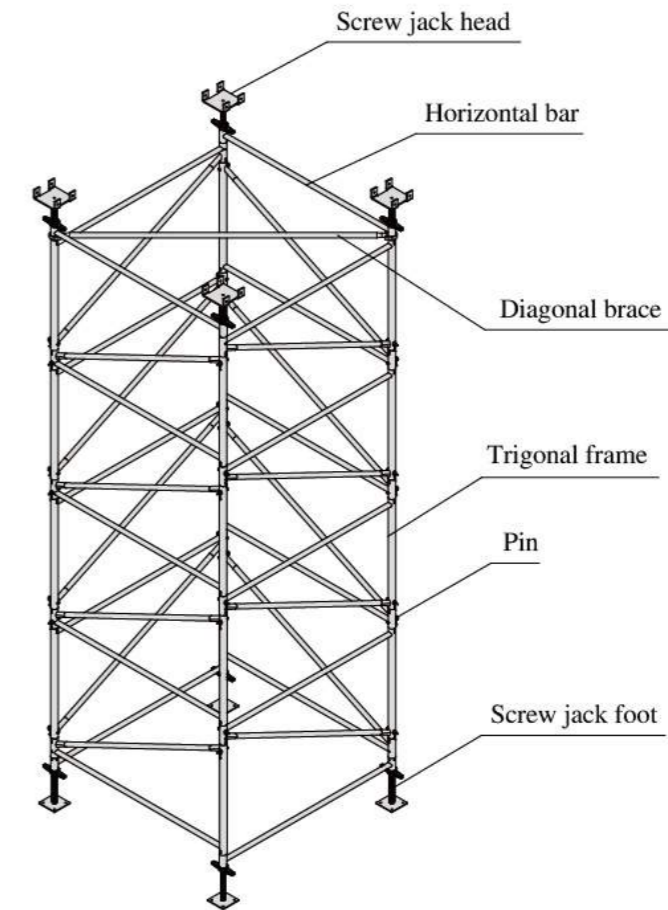

The bearing capacity of triangular tower (take cross section 1500X1500mm as an example)

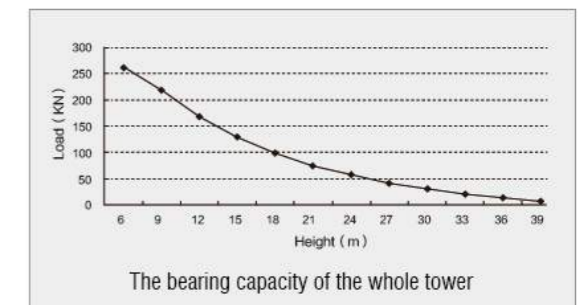
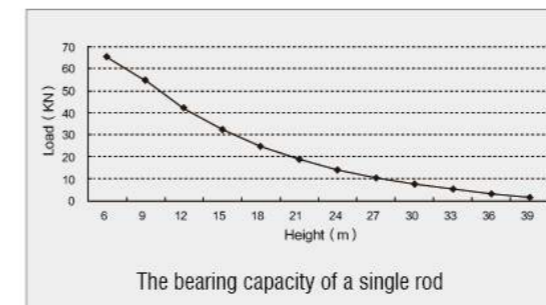

Third: $\phi 60$ rectangular tower

This type of tower has a variety of cross-section dimensions, with minimum dimension of 1.0 x 1.5 m and maximum dimension of 1.5 x 2.5 m.

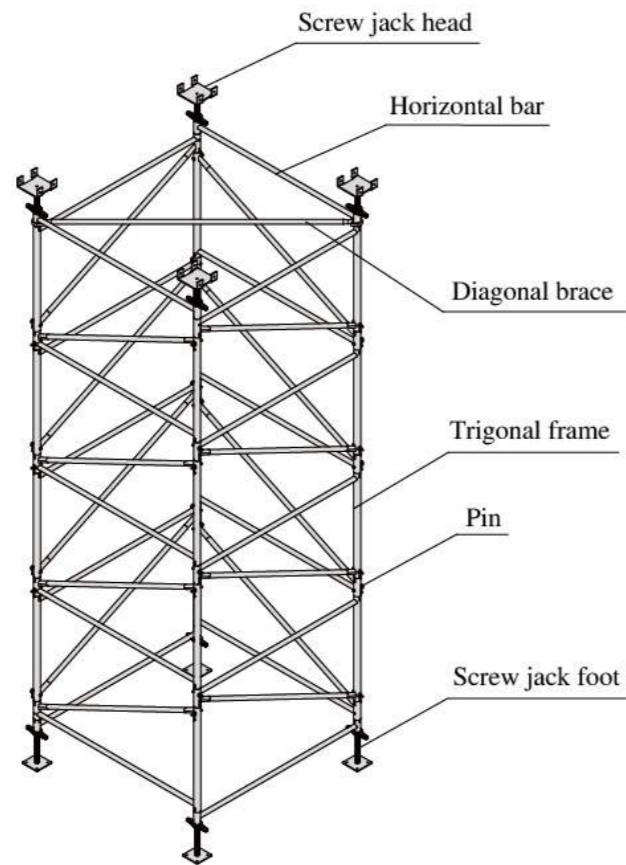

The bearing capacity of rectangular tower (take H=1800 standard frame and cross-section 1500x1500mm as an example)

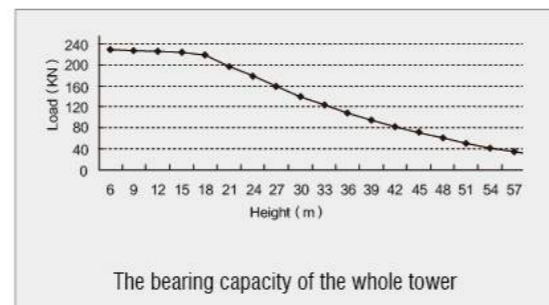
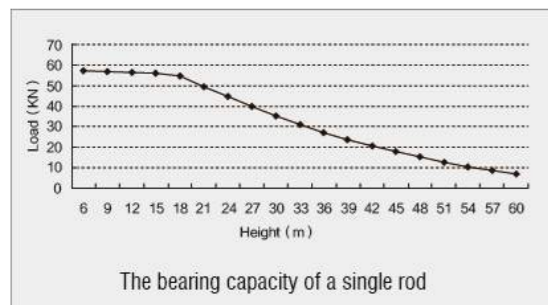

Schematic diagram of towers in various structural applications

1. Ordinary structure

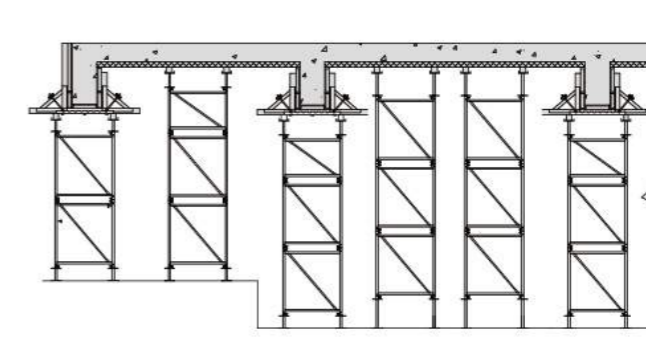

2. Heavy load structure

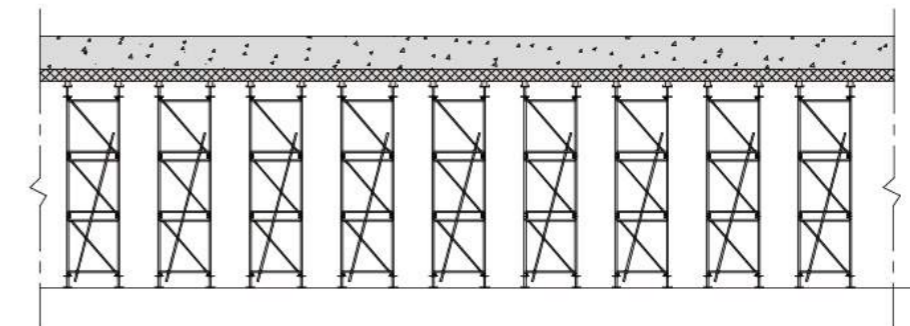

3. Special structure

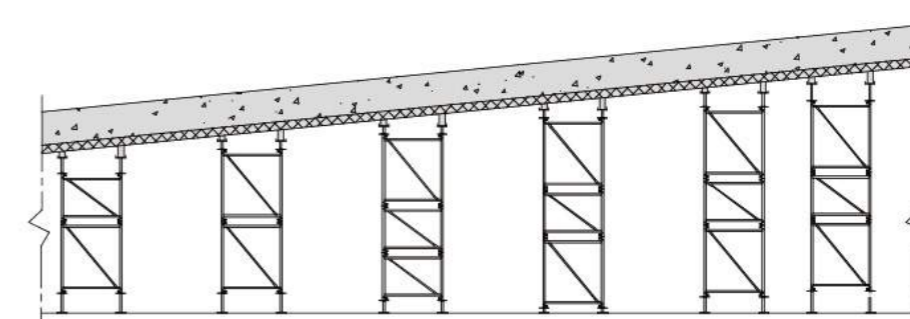

Pipe Gallery Trolley



Pipe Gallery Trolley

Introduction

Pipe gallery is a tunnel built underground in a city, integrating various engineering pipe galleries such as electric power, telecommunication, gas, heat and water supply and drainage system. There is special inspection port, lifting port and monitoring system, and planning, design, construction and management for the whole system have been consolidated and implemented. It is an important infrastructure and lifeline for a city's running and management. To suit the market need, our company has developed the TC-120 pipe gallery trolley system. It is a new model trolley which ergonomically integrates the formwork system and trolley into a unity. The formwork can be installed and removed easily by adjusting the spindle strut of the trolley, without disassembling the whole system, thus achieving a safe and quick construction rationale.

Structure diagram of pipe gallery trolley

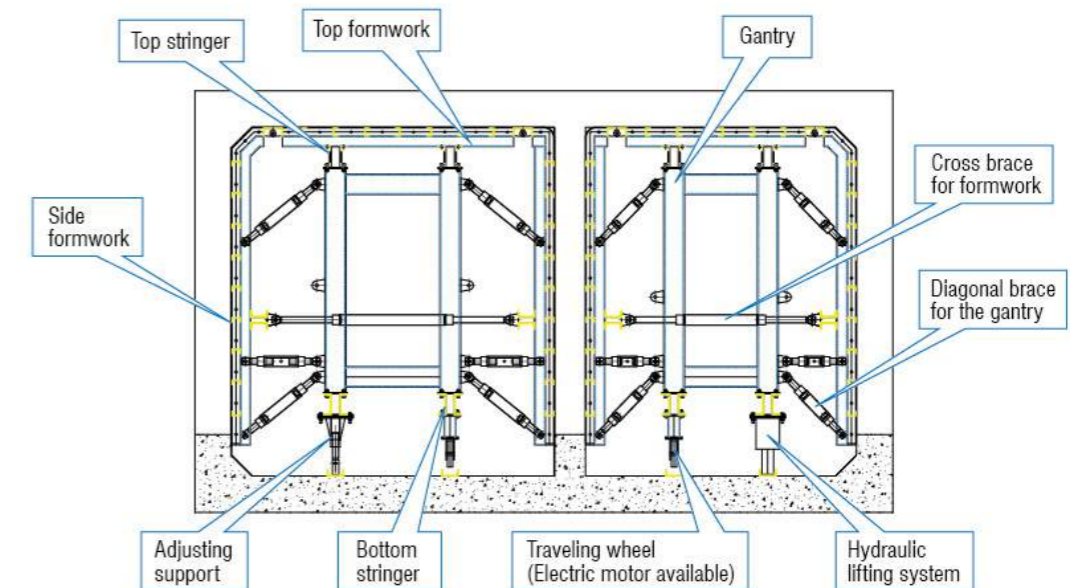

The trolley system is divided into semi-automatic traveling system and fully automatic traveling system.

- ◆ **Semi-automatic traveling system** : The trolley system consists of gantry, formwork support system, hydraulic lifting system, adjustment support and traveling wheel. It needs to be dragged forward by a pulling device such as a hoist.
- ◆ **Fully-automatic traveling system**: The trolley system consists of gantry, formwork support system, hydraulic lifting system, adjustment support and electric traveling wheel. It only needs to press the button to move forward or backward.

Characteristics of TC-120 pipe gallery trolley

- The pipe gallery trolley system transmits all the loads generated by the concrete to the trolley gantry through the support system. The structural principle is simple and the force is reasonable. It has the characteristics of large rigidity, convenient operation and high safety factor.
- The pipe gallery trolley system has a large operating space, which is convenient for workers to operate and related personnel to visit and inspect.
- Quick and easy to install, fewer parts required, not easy to lose, easy to clean on site
- After one-time assembly of the trolley system, there is no need to disassemble and it can be put into recyclable use.
- The formwork of pipe gallery trolley system has the advantages of short erection time (according to the specific situation of the site, the regular time is about half a day), less personnel, and long-term turnover can reduce the construction period and cost of manpower as well.

Assembly process of TC-120 pipe gallery trolley system

◆ Material checking

After entering the field, check the materials to ensure that the materials are consistent with the purchase list.

◆ Site preparation

Before installing the TC-120 pipe gallery trolley system, the bottom of the pipe and the guide walls on both sides should be poured in advance (the formwork needs to be wrapped 100mm)



Site preparation before installation

◆ Installation of bottom stringer

The adjustment support, the traveling wheel and the hydraulic lifting system are connected to the bottom stringer. Place the traveling trough according to the drawing mark (I16 channel steel, prepared by site), and extend the adjustment support beyond the hydraulic lifting system and the traveling wheel, install the connected bottom stringer. As shown below:

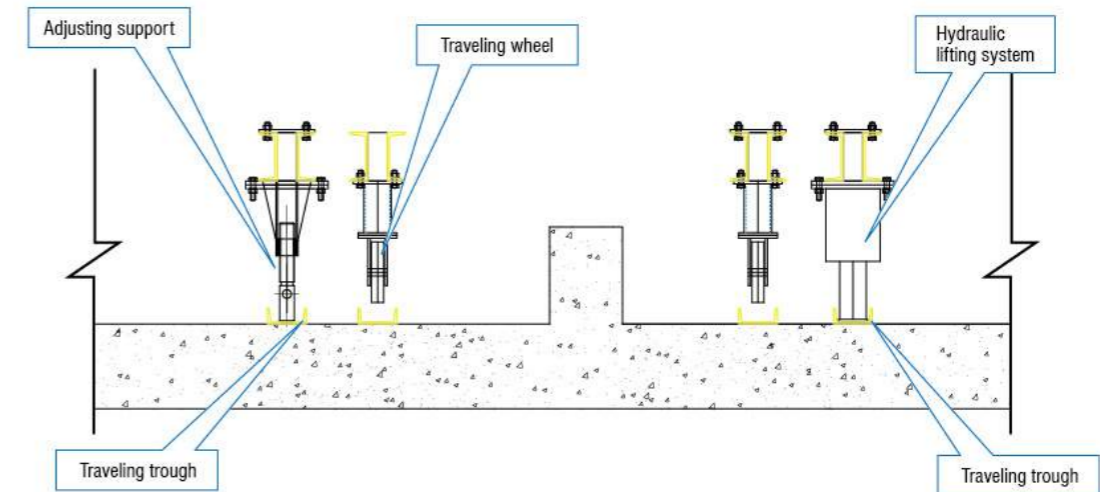

Installation diagram of the bottom stringer

◆ Mounting gantry

Connect the door handle to the bottom stringer. As shown below:



Connection of bottom stringer and gantry

◆ **Installation of top stringers and formwork**

After Connecting the gantry to the top stringer, then connect the formwork . After the side formwork being installed and adjusted, the surface should be smooth and flat, the joints are free of faults, and the geometric dimensions meet the design requirements. As shown below:



Installation of top stringer and formwork

◆ **Installation of the formwork support**

Connect the cross brace of the formwork with the diagonal brace of the gantry to the formwork. As shown below:



Installation of the cross brace of the top formwork and the diagonal brace of the gantry

◆ **Installation of motor and circuit**

Install hydraulic system motor and electric traveling wheel motor, add 46# hydraulic oil, and connect the circuit. As shown below:



Installation of motor and circuit

◆ **Testing**

After the first installation, the pipe gallery trolley system must be tested, and used after testing.

Testing items:

- Whether the hydraulic lifting system and the electric traveling wheel motor rotate normally;
- Whether the hydraulic lifting system cylinder is working properly;
- Whether the hydraulic cylinder and hydraulic pipe leak oil;
- Whether the electric traveling wheel is normal when walking;

◆ **Acceptance**

After the pipe gallery trolley system is properly tested, it is reported to the user for acceptance. After the acceptance is passed, the two parties sign the form and put it into use.

Project application of pipe gallery trolley



Hydraulic Tunnel Lining Trolley

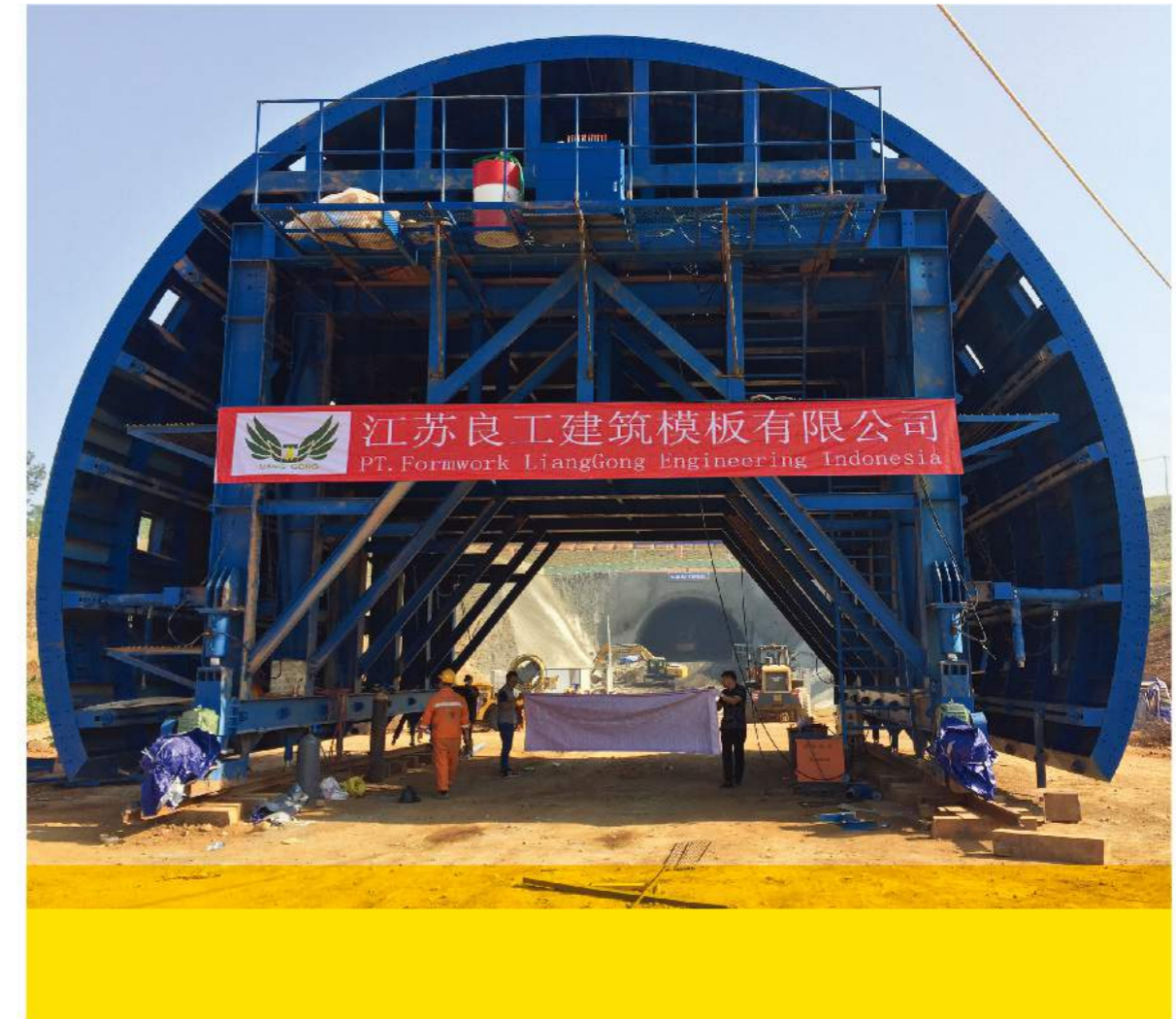

Introduction

Designed and developed by our own company, hydraulic tunnel lining trolley is an ideal system for formwork lining of railway and highway tunnels. Driven by electrical motors, it is able to move and walk by itself, with hydraulic cylinder and screw jack being used to position and retrieve the formwork. The trolley has many advantages in operation, such as low cost, reliable structure, convenient operation, fast lining speed and good tunnel surface.

Structure diagram of hydraulic tunnel lining trolley

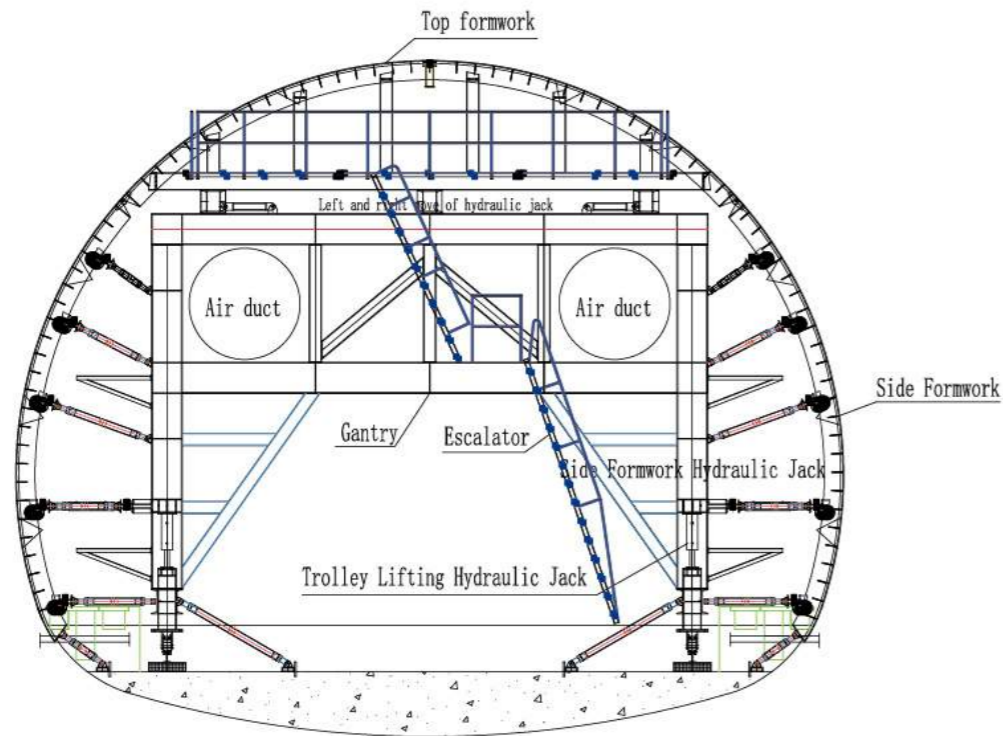

Elevation layout drawing of Hydraulic Tunnel Lining Trolley

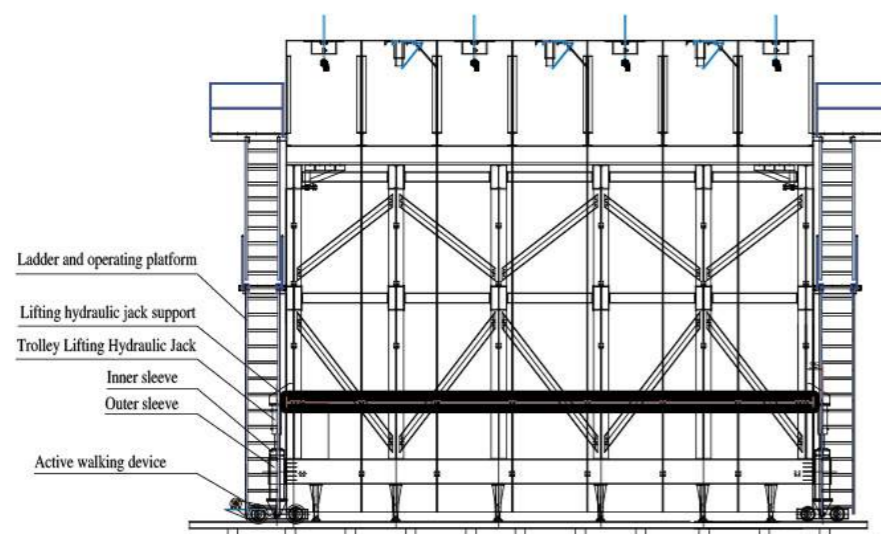

Side layout drawing of Hydraulic Tunnel Lining Trolley

Technical parameters

- ◆ Specifications: 6-12m
- ◆ Maximum lining length: $L=12\text{m}$ (can be adjusted according to the customers) per unit
- ◆ Maximum passing capacity: (height * width) construction does not affect the car at the same time
- ◆ Crawling ability: 4%
- ◆ Walking speed: 8m/min
- ◆ Total power: 22.5KW Traveling motor $7.5\text{KW} \times 2 = 15\text{KW}$
oil pump motor 7.5KW
- ◆ Pressure of hydraulic system: $P_{\text{max}}=16\text{Mpa}$
- ◆ Unilateral modulus removal of formwork: $A_{\text{min}}=150$
- ◆ Left and right adjustment of horizontal cylinder: $B_{\text{max}}=100\text{mm}$
- ◆ Lifting cylinder: 300mm
- ◆ Maximum stroke of the cylinder: lateral cylinder 300mm
- ◆ Horizontal cylinder: 250mm

Project application of hydraulic tunnel lining trolley



Project name: Jakarta-Bandung High Speed Railway

Contractor: High Speed Railway Contractor Consortium- Project Team China Railway Group Limited

Products Utilized: Hydraulic Tunnel Lining Trolley

Other formworks

Steel formwork

Our company can design and manufacture various specifications of steel formwork according to the characteristics of the project and requirements of customers.



Project name: Jakarta-Bandung High Speed Railway
Contractor: High Speed Railway Contractor Consortium- Project Team China Railway Group Limited
Products Utilized: Steel Formwork

Steel frame formwork

Steel frame formwork consists of steel frame and plywood. After the system is assembled, a whole frame is formed, which has good stability and high bearing capacity. Several independent systems, such as wall formwork, slab formwork and support system, are integrated organically, which means all the formwork is assembled in one time, and so is concrete pouring.



Customized Steel Frame Formwork

Cantilever forming traveller

Cantilever forming traveller is the main equipment in cantilever construction. According to the structure, they can be divided into four types: truss type, diagonal type, channel steel type and hybrid type. As per the requirements for cantilever construction and design drawings, comprehensive comparison of various cantilever forming travellers shall be done for their characteristics, weight, steel type, construction technology, etc. The principles of designing are to make them light-weighted with simple structure, firm and stable, easy to move forward, assemble and disassemble, with strong reusability, small deformation after loading, and sufficient space for operation under the traveller, and easy for rebar working.





Project name: Jakarta-Bandung High Speed Railway
Contractor: High Speed Railway Contractor Consortium- Project Team China Railway Group Limited
Products Utilized: Cantilever Forming Traveler



Accessory system

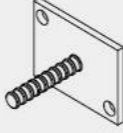
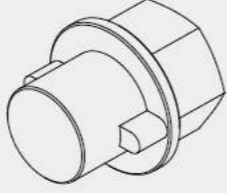

Number	Description and specification	Weight (kg)	3D Picture
31100100	M24/D15 Climbing cone	1.99	
31100200	M30/D15 Climbing cone	2.50	
31100300	M30/D20 Climbing cone	2.50	
31100400	M36/D20 Climbing cone	3.72	
31100500	M36/D25 Climbing cone	3.57	
31100600	M36/D26.5 Climbing cone	4.15	
31100700	M42/D20 Climbing cone	5.64	
31100800	M42/D25 Climbing cone	4.97	
31100900	M42/D26.5 Climbing cone	5.64	
31101000	M64-D26.5 Climbing cone	17.19	
31101100	M30 Installing bolt L=50	0.48	
31101200	M36 Installing bolt L=50	0.78	
31101300	M42 Positioning bolt L=50	1.2	
31101400	M30 Positioning bolt	0.33	
31101500	M36 Positioning bolt	0.47	
31101600	M42 Positioning bolt	0.79	
31101700	D15 Anchor plate	0.83	
31101800	D20 Anchor plate	1.2	
31102000	D25 Anchor plate	2.07	
31102100	D26.5 Anchor plate	2.07	

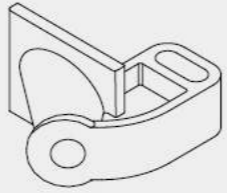
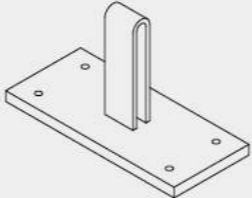
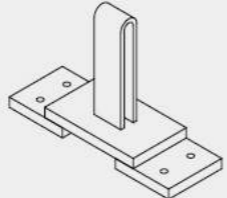
Accessory system

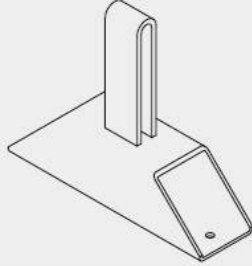
Number	Description and specification	Weight (kg)	3D Picture
31101900	D20×115 Welding anchor plate	1.03	
31102200	D15 Taken out tool for climbing cone	0.26	
31102300	D20(M24) Taken out tool for casting climbing cone	0.45	
31102500	M36 Taken out tool for casting climbing cone	0.9	
31102600	M42 Taken out tool for casting climbing cone	1.45	
31102700	M64 Taken out tool for casting climbing cone	4.06	
31102800	D15 High-strength tie rod L=300	0.42	
31102900	D20 High-strength tie rod L=300	0.74	
31103000	D26.5 High-strength tie rod L=300	0.74	

99000161	[10 Cast tie yoke	2.2	
99000162	[12 Cast tie yoke	2.3	
99000163	[14~[16 Cast tie yoke	2.6	
99000164	[10 Coupling connector	1.44	
99000165	[12 Coupling connector	1.47	

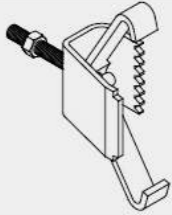
99000166	[14~[16 Coupling connector	1.09	
99000167	Wedge	0.61	
99000168	Hook-headed bolt L=145	0.18	
99000169	Hook-headed bolt L=253	0.31	

Number	Description	Weight (kg)	3D Picture
99000081	[12~[14 Flange clamp 50mm	0.74	
99000082	[16~[18 Flange clamp 50mm	0.88	
99000084	H20 Lifting hook	4.65	
99000085	H20 Connecting plate	4.84	

Accessory system

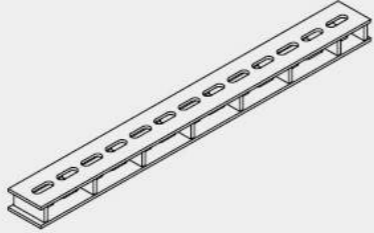
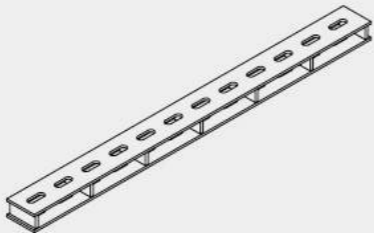
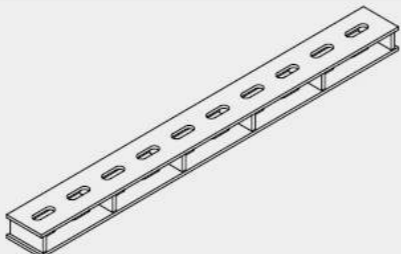
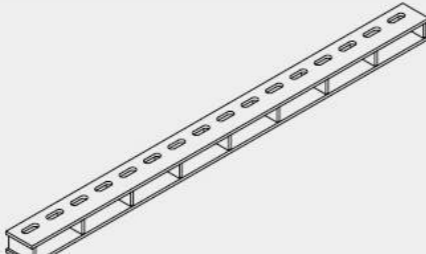
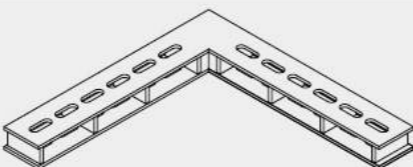
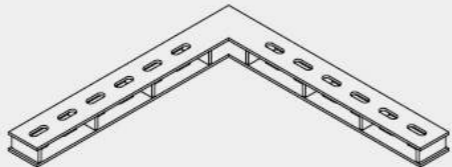
Number	Description	Weight (kg)	3D Picture
99000121	[10 Straight coupling L=820	6.96	
99000131	[12 Straight coupling L=660	6.25	
99000134	[12 Straight coupling L=820	7.82	
99000141	[14 Straight coupling L=1220	11.51	
99000122	[10 Right angle coupling 475×475	8.44	
99000132	[12 Right angle coupling 620×620	11.24	

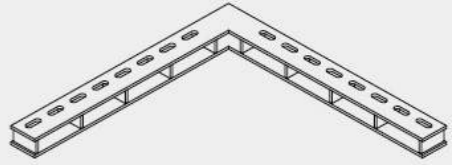
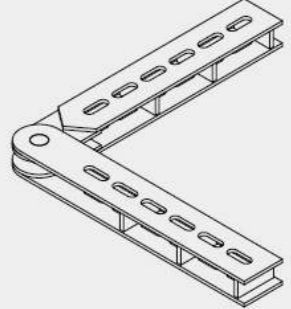
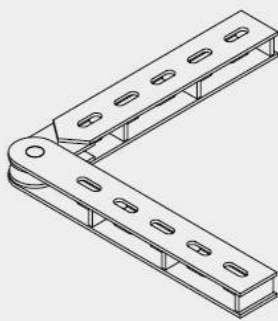
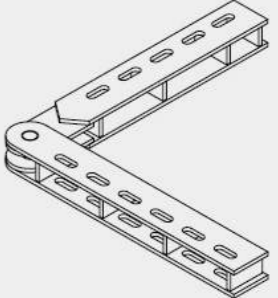
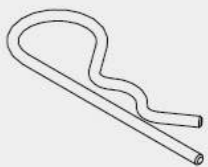
Number	Description	Weight (kg)	3D Picture
99000142	[14 Right angle coupling 730×730	13.25	
99000123	[10 Movable coupling 510×510	9.78	
99000133	[12 Movable coupling 610×610	11.82	
99000143	[14 Movable coupling 630×630	12.16	
99000501	Hairpin ϕ 3/L170	0.009	

Worldwide Service

Our products and services are suited to the actual situation and market needs of each country.

